

**Oracle® OLAP**

Java API Developer's Guide

12c Release 2 (12.2)

**E49949-08**

January 2017

Oracle OLAP Java API Developer's Guide, 12c Release 2 (12.2)

E49949-08

Copyright © 2000, 2017, Oracle and/or its affiliates. All rights reserved.

Primary Author: David McDermid

Contributors: David Greenfield, Jim Hartsing, Scott Feinstein, Anne Murphy, Richard Samuels, Steve Mesropian, Chuck Venezia, Afsaneh Koochek

This software and related documentation are provided under a license agreement containing restrictions on use and disclosure and are protected by intellectual property laws. Except as expressly permitted in your license agreement or allowed by law, you may not use, copy, reproduce, translate, broadcast, modify, license, transmit, distribute, exhibit, perform, publish, or display any part, in any form, or by any means. Reverse engineering, disassembly, or decompilation of this software, unless required by law for interoperability, is prohibited.

The information contained herein is subject to change without notice and is not warranted to be error-free. If you find any errors, please report them to us in writing.

If this is software or related documentation that is delivered to the U.S. Government or anyone licensing it on behalf of the U.S. Government, then the following notice is applicable:

U.S. GOVERNMENT END USERS: Oracle programs, including any operating system, integrated software, any programs installed on the hardware, and/or documentation, delivered to U.S. Government end users are "commercial computer software" pursuant to the applicable Federal Acquisition Regulation and agency-specific supplemental regulations. As such, use, duplication, disclosure, modification, and adaptation of the programs, including any operating system, integrated software, any programs installed on the hardware, and/or documentation, shall be subject to license terms and license restrictions applicable to the programs. No other rights are granted to the U.S. Government.

This software or hardware is developed for general use in a variety of information management applications. It is not developed or intended for use in any inherently dangerous applications, including applications that may create a risk of personal injury. If you use this software or hardware in dangerous applications, then you shall be responsible to take all appropriate fail-safe, backup, redundancy, and other measures to ensure its safe use. Oracle Corporation and its affiliates disclaim any liability for any damages caused by use of this software or hardware in dangerous applications.

Oracle and Java are registered trademarks of Oracle and/or its affiliates. Other names may be trademarks of their respective owners.

Intel and Intel Xeon are trademarks or registered trademarks of Intel Corporation. All SPARC trademarks are used under license and are trademarks or registered trademarks of SPARC International, Inc. AMD, Opteron, the AMD logo, and the AMD Opteron logo are trademarks or registered trademarks of Advanced Micro Devices. UNIX is a registered trademark of The Open Group.

This software or hardware and documentation may provide access to or information about content, products, and services from third parties. Oracle Corporation and its affiliates are not responsible for and expressly disclaim all warranties of any kind with respect to third-party content, products, and services unless otherwise set forth in an applicable agreement between you and Oracle. Oracle Corporation and its affiliates will not be responsible for any loss, costs, or damages incurred due to your access to or use of third-party content, products, or services, except as set forth in an applicable agreement between you and Oracle.

---

---

# Contents

Preface .....	xi
Audience .....	xi
Documentation Accessibility .....	xi
Related Documents.....	xii
Conventions.....	xii
Changes in This Release for Oracle OLAP Java API Developer's Guide .....	xiii
Changes in Oracle Database 12c Release 1 (12.1).....	xiii
Desupported Features .....	xiii
<b>1 Introduction to the OLAP Java API</b>	
1.1 OLAP Java API Overview .....	1-1
1.1.1 What the OLAP Java API Can Do.....	1-1
1.1.2 Describing the Classes in the OLAP Java API.....	1-2
1.1.3 Describing the Dimensional Data Model.....	1-3
1.1.4 Implementing the Dimensional Data Model.....	1-5
1.1.5 Organizing the Data for OLAP.....	1-5
1.2 Accessing Data Through the OLAP Java API.....	1-6
1.2.1 Creating Queries.....	1-6
1.2.2 Specifying Dimension Members .....	1-6
1.2.3 Creating Cursors.....	1-7
1.3 Sample Schema for OLAP Java API Examples.....	1-7
1.4 Tasks That an OLAP Java API Application Performs .....	1-8
<b>2 Understanding OLAP Java API Metadata</b>	
2.1 Overview of OLAP Java API Metadata Classes.....	2-1
2.2 Identifying, Describing, and Classifying Metadata Objects .....	2-3
2.2.1 Identifying Objects .....	2-3
2.2.2 Using Descriptions .....	2-6
2.2.3 Using Classifications.....	2-8
2.3 Providing Metadata Objects.....	2-9

2.3.1	Describing Metadata Providers.....	2-9
2.3.2	Representing Schemas.....	2-12
2.4	Providing Access to Data Sources.....	2-15
2.4.1	Representing Cubes and Measures.....	2-15
2.4.2	Representing Dimensions, Levels, and Hierarchies.....	2-19
2.4.3	Representing Dimension Attributes.....	2-23
2.4.4	Using OLAP Views.....	2-28
<b>3</b>	<b>Discovering Metadata</b>	
3.1	Connecting to Oracle OLAP.....	3-1
3.1.1	Prerequisites for Connecting.....	3-1
3.1.2	Establishing a Connection.....	3-2
3.1.3	Closing the Connection and the DataProvider.....	3-3
3.2	Overview of the Procedure for Discovering Metadata.....	3-3
3.2.1	Purpose of Discovering the Metadata.....	3-4
3.2.2	Steps in Discovering the Metadata.....	3-4
3.3	Creating an MdmMetadataProvider.....	3-4
3.4	Getting the MdmSchema Objects.....	3-5
3.5	Getting the Contents of an MdmSchema.....	3-6
3.6	Getting the Objects Contained by an MdmPrimaryDimension.....	3-7
3.6.1	Getting the Hierarchies and Levels of an MdmPrimaryDimension.....	3-7
3.6.2	Getting the Attributes for an MdmPrimaryDimension.....	3-8
3.7	Getting the Source for a Metadata Object.....	3-9
<b>4</b>	<b>Creating Metadata and Analytic Workspaces</b>	
4.1	Overview of Creating and Mapping Metadata.....	4-1
4.2	Creating an Analytic Workspace.....	4-2
4.3	Creating the Dimensions, Levels, and Hierarchies.....	4-2
4.3.1	Creating and Mapping Dimensions.....	4-3
4.3.2	Creating and Mapping Dimension Levels.....	4-3
4.3.3	Creating and Mapping Hierarchies.....	4-4
4.4	Creating Attributes.....	4-7
4.5	Creating Cubes and Measures.....	4-8
4.5.1	Creating Cubes.....	4-8
4.5.2	Creating and Mapping Measures.....	4-9
4.6	Committing Transactions.....	4-10
4.7	Exporting and Importing XML Templates.....	4-11
4.8	Building an Analytic Workspace.....	4-11
<b>5</b>	<b>Understanding Source Objects</b>	
5.1	Overview of Source Objects.....	5-1
5.2	Kinds of Source Objects.....	5-2
5.3	Characteristics of Source Objects.....	5-3

5.3.1	Elements and Values of a Source .....	5-3
5.3.2	Data Type of a Source .....	5-3
5.3.3	Type of a Source .....	5-4
5.3.4	Source Identification and SourceDefinition of a Source .....	5-5
5.4	Inputs and Outputs of a Source .....	5-6
5.4.1	Describing the join Method.....	5-6
5.4.2	Outputs of a Source.....	5-8
5.4.3	Inputs of a Source .....	5-11
5.4.4	Matching a Source with an Input.....	5-13
5.5	Describing Parameterized Source Objects .....	5-18
<b>6</b>	<b>Making Queries Using Source Methods</b>	
6.1	Describing the Basic Source Methods.....	6-1
6.2	Using the Basic Methods .....	6-2
6.2.1	Using the alias Method.....	6-2
6.2.2	Using the distinct Method.....	6-4
6.2.3	Using the join Method .....	6-5
6.2.4	Using the position Method .....	6-6
6.2.5	Using the recursiveJoin Method.....	6-7
6.2.6	Using the value Method .....	6-10
6.3	Using Other Source Methods.....	6-13
6.3.1	Using the extract Method .....	6-14
6.3.2	Creating a Cube and Pivoting Edges.....	6-14
6.3.3	Drilling Up and Down in a Hierarchy .....	6-17
6.3.4	Sorting Hierarchically by Measure Values .....	6-19
6.3.5	Using NumberSource Methods To Compute the Share of Units Sold .....	6-20
6.3.6	Selecting Based on Time Series Operations.....	6-21
6.3.7	Selecting a Set of Elements Using Parameterized Source Objects.....	6-23
<b>7</b>	<b>Using a TransactionProvider</b>	
7.1	About Creating a Metadata Object or a Query in a Transaction .....	7-1
7.1.1	Types of Transaction Objects .....	7-2
7.1.2	Committing a Transaction.....	7-3
7.1.3	About Transaction and Template Objects .....	7-3
7.1.4	Beginning a Child Transaction .....	7-3
7.1.5	About Rolling Back a Transaction.....	7-4
7.1.6	Getting and Setting the Current Transaction .....	7-6
7.2	Using TransactionProvider Objects .....	7-7
<b>8</b>	<b>Understanding Cursor Classes and Concepts</b>	
8.1	Overview of the OLAP Java API Cursor Objects.....	8-1
8.1.1	Creating a Cursor .....	8-1
8.1.2	Sources For Which You Cannot Create a Cursor.....	8-2

8.1.3	Cursor Objects and Transaction Objects .....	8-2
8.2	Cursor Classes .....	8-2
8.2.1	Structure of a Cursor .....	8-3
8.2.2	Specifying the Behavior of a Cursor .....	8-5
8.3	CursorInfoSpecification Classes .....	8-5
8.4	CursorManager Class .....	8-7
8.4.1	Updating the CursorInfoSpecification for a CursorManager .....	8-7
8.5	About Cursor Positions and Extent .....	8-7
8.5.1	Positions of a ValueCursor .....	8-7
8.5.2	Positions of a CompoundCursor .....	8-8
8.5.3	About the Parent Starting and Ending Positions in a Cursor .....	8-12
8.5.4	What is the Extent of a Cursor? .....	8-12
8.6	About Fetch Sizes .....	8-13
<b>9</b>	<b>Retrieving Query Results</b>	
9.1	Retrieving the Results of a Query .....	9-1
9.1.1	Getting Values from a Cursor .....	9-2
9.2	Navigating a CompoundCursor for Different Displays of Data .....	9-6
9.3	Specifying the Behavior of a Cursor .....	9-12
9.4	Calculating Extent and Starting and Ending Positions of a Value .....	9-13
9.5	Specifying a Fetch Size .....	9-15
<b>10</b>	<b>Creating Dynamic Queries</b>	
10.1	About Template Objects .....	10-1
10.1.1	About Creating a Dynamic Source .....	10-1
10.1.2	About Translating User Interface Elements into OLAP Java API Objects .....	10-2
10.2	Overview of Template and Related Classes .....	10-2
10.2.1	What Is the Relationship Between the Classes That Produce a Dynamic Source? ..	10-2
10.2.2	Template Class .....	10-3
10.2.3	MetadataState Interface .....	10-3
10.2.4	SourceGenerator Interface .....	10-3
10.2.5	DynamicDefinition Class .....	10-4
10.3	Designing and Implementing a Template .....	10-4
10.3.1	Implementing the Classes for a Template .....	10-5
10.3.2	Implementing an Application That Uses Templates .....	10-9
<b>A</b>	<b>Setting Up the Development Environment</b>	
A.1	Overview .....	A-1
A.2	Required Class Libraries .....	A-1
A.3	Obtaining the Class Libraries .....	A-2
<b>B</b>	<b>SingleSelectionTemplate Class</b>	
B.1	Code for the SingleSelectionTemplate Class .....	B-1

## Index





## List of Figures

2-1	The oracle.olapi.metadata Packages.....	2-2
2-2	MdmObject and MdmDescription Associations.....	2-8
2-3	Methods for Getting and Setting Descriptions Before 11g.....	2-8
2-4	Associations Between MdmMetadataProvider and the MdmSchema Subclasses.....	2-13
2-5	Associations of Dimensional Data Model Classes.....	2-15
2-6	MdmCube and Associated Objects.....	2-17
2-7	Regular, Ragged, and Skip-level Hierarchies.....	2-22
8-1	Structure of the queryCursor CompoundCursor.....	8-4
8-2	Cursor Positions in queryCursor.....	8-9
8-3	Crosstab Display of queryCursor.....	8-9
8-4	A Source and Two Cursors for Different Views of the Values.....	8-13



---

# Preface

*Oracle OLAP Java API Developer's Guide* introduces Java programmers to the Oracle OLAP Java API, which is the Java application programming interface for Oracle OLAP. Through Oracle OLAP, the OLAP Java API provides access to data stored in an Oracle database, particularly data in an analytic workspace. The OLAP Java API capabilities for creating and maintaining analytic workspaces, and for querying, manipulating, and presenting data are particularly suited to applications that perform online analytical processing (OLAP) operations.

The preface contains these topics:

- [Audience](#) (page xi)
- [Documentation Accessibility](#) (page xi)
- [Related Documents](#) (page xii)
- [Conventions](#) (page xii)

## Audience

*Oracle OLAP Java API Developer's Guide* is intended for Java programmers who are responsible for creating applications that do one or more of the following:

- Implement an Oracle OLAP metadata model.
- Define, build, and maintain analytic workspaces.
- Perform analysis using Oracle OLAP.

To use this manual, you should be familiar with Java, relational database management systems, data warehousing, OLAP concepts, and Oracle OLAP.

## Documentation Accessibility

For information about Oracle's commitment to accessibility, visit the Oracle Accessibility Program website at <http://www.oracle.com/pls/topic/lookup?ctx=acc&id=docacc>.

### Access to Oracle Support

Oracle customers that have purchased support have access to electronic support through My Oracle Support. For information, visit <http://www.oracle.com/pls/topic/lookup?ctx=acc&id=info> or visit <http://www.oracle.com/pls/topic/lookup?ctx=acc&id=trs> if you are hearing impaired.

## Related Documents

For more information, see these Oracle resources:

- *Oracle OLAP Java API Reference*
- *Oracle OLAP User's Guide*
- *Oracle OLAP DML Reference*

## Conventions

The following text conventions are used in this document:

---

<b>Convention</b>	<b>Meaning</b>
<b>boldface</b>	Boldface type indicates graphical user interface elements associated with an action, or terms defined in text or the glossary.
<i>italic</i>	Italic type indicates book titles, emphasis, or placeholder variables for which you supply particular values.
monospace	Monospace type indicates commands within a paragraph, URLs, code in examples, text that appears on the screen, or text that you enter.

---

---

# Changes in This Release for Oracle OLAP Java API Developer's Guide

This preface lists changes in *Oracle OLAP Java API Developer's Guide*.

## Changes in Oracle Database 12c Release 1 (12.1)

The following are changes in *Oracle OLAP Java API Developer's Guide* for Oracle Database 12c Release 1 (12.1).

## Desupported Features

Some features previously described in this document are desupported in Oracle Database 12c Release 1 (12.1). See *Oracle Database Upgrade Guide* for information on desupported features.



---

# Introduction to the OLAP Java API

This chapter introduces the Oracle OLAP Java application programming interface (API). The chapter includes the following topics:

- [OLAP Java API Overview](#) (page 1-1)
- [Accessing Data Through the OLAP Java API](#) (page 1-6)
- [Sample Schema for OLAP Java API Examples](#) (page 1-7)
- [Tasks That an OLAP Java API Application Performs](#) (page 1-8)

## 1.1 OLAP Java API Overview

The Oracle OLAP Java API is an application programming interface that provides access to the online analytic processing (OLAP) technology in Oracle Database with the OLAP option. This topic lists operations that an OLAP Java API client application can perform, describes the classes in the OLAP Java API, describes the objects in a dimensional data model, and discusses organizing data for online analytical processing.

For a description of the advantages of OLAP technology, see *Oracle OLAP User's Guide*. That document describes the capabilities that Oracle OLAP provides for the analysis of multidimensional data by business intelligence and advanced analytical applications. It describes in depth the dimensional data model, and it discusses the database administration and management tasks related to Oracle OLAP.

### 1.1.1 What the OLAP Java API Can Do

Using the OLAP Java API, you can develop client applications that do the following operations.

- Establish one or more user sessions in a JDBC connection to an Oracle Database instance. Multiple user sessions can share the same connection and the same cache of metadata objects.
- Manage OLAP transactions with the database.
- Implement a dimensional data model using OLAP metadata objects.
- Create and maintain analytic workspaces.
- Create logical metadata objects and map them to relational sources.
- Deploy the metadata objects as an analytic workspace or as relational tables and views and commit the objects to the database.
- Explore the metadata to discover the data that is available for viewing or for analysis.

- Construct analytical queries of the multidimensional data. Enable end users to create queries that specify and manipulate the data according to the needs of the user (for example, selecting, aggregating, and calculating data).
- Modify queries, rather than totally redefine them, as application users refine their analyses.
- Retrieve query results that are structured for display in a multidimensional format.

For more information on some of these operations, see "[Tasks That an OLAP Java API Application Performs](#) (page 1-8)".

## 1.1.2 Describing the Classes in the OLAP Java API

The OLAP Java API has classes that represent the following types of objects.

- User sessions
- Transactions
- Metadata objects
- Build items, processes, specifications, and commands
- Queries
- Cursors that retrieve the data of a query
- Expressions that specify data objects, such as a column in a relational table or view, or that specify a function or command that operates on data

[Table 1-1](#) (page 1-2) lists packages that contain the majority of the OLAP Java API classes. These packages are under the `oracle.olapi` package. The table contains brief descriptions of the package contents.

**Table 1-1 Packages of the OLAP Java API under `oracle.olapi`**

Package	Description
<code>data.cursor</code>	Contains classes that represent cursor managers and cursors that retrieve the data specified by a <code>Source</code> object. For information on <code>Cursor</code> objects, see <a href="#">Understanding Cursor Classes and Concepts</a> (page 8-1) and <a href="#">Retrieving Query Results</a> (page 9-1).
<code>data.source</code>	Contains classes that represent data sources and cursor specifications. You use <code>Source</code> objects to create queries of the data store. With the <code>Template</code> class you can incrementally build a <code>Source</code> object that represents a query that you can dynamically modify. For information on <code>Source</code> objects, see <a href="#">Understanding Source Objects</a> (page 5-1) and <a href="#">Making Queries Using Source Methods</a> (page 6-1). For information on <code>Template</code> objects, see <a href="#">Creating Dynamic Queries</a> (page 10-1).



**Table 1-1 (Cont.) Packages of the OLAP Java API under oracle.olapi**

Package	Description
metadata metadata.deployment metadata.mapping metadata.mdm	Contains classes that represent metadata objects, classes that map the metadata objects to relational data sources, and classes that deploy the metadata objects in an analytic workspace or in relational database structures. For a description of these packages, see <a href="#">Understanding OLAP Java API Metadata</a> (page 2-1). For information on using the classes in these packages, see <a href="#">Discovering Metadata</a> (page 3-1) and <a href="#">Creating Metadata and Analytic Workspaces</a> (page 4-1).
resource	Contains classes that support the internationalization of messages for <code>Exception</code> classes.
session	Contains a class that represents a session in a connection to an Oracle database.
syntax	Contains classes that represent the items and commands that specify how Oracle OLAP builds analytic workspace objects and classes that implement a syntax for creating SQL-like expressions. You use <code>Expression</code> objects in mapping metadata objects to relational data sources such as columns in a table or a view. You also use <code>Expression</code> objects to specify calculations and analytical operations for some metadata objects.
transaction	Contains classes that represent transactions with Oracle OLAP in an Oracle Database instance. You use <code>Transaction</code> objects to commit changes to the database. For information on <code>Transaction</code> objects, see <a href="#">Using a TransactionProvider</a> (page 7-1).

The OLAP Java API also has packages organized under the `oracle.express` package. These packages date from the earliest versions of the API. The classes that remain in these packages are mostly `Exception` classes for exceptions that occur during interactions between Oracle OLAP and a client application.

For information on obtaining the OLAP Java API software and on the requirements for using it to develop applications, see [Setting Up the Development Environment](#) (page A-1).

### 1.1.3 Describing the Dimensional Data Model

Data warehousing and OLAP applications are based on a multidimensional view of data. This view is implemented in a dimensional data model that includes the following dimensional objects. For more detailed information about these concepts, see *Oracle OLAP User's Guide*.

#### Cubes

Cubes are containers for measures that have the same set of dimensions. A cube usually corresponds to a single relational fact table or view. The measures of a cube contain facts and the dimensions give shape to the fact data. Typically, the dimensions form the edges of the cube and the measure data is the body of the cube. For example, you could organize data on product units sold into a cube whose edges contain values for members from time, product, customer, and channel dimensions

and whose body contains values from a measure of the quantity of units sold and a measure of sales amounts.

The OLAP concept of a cube edge is not represented by a metadata object in the OLAP Java API, but edges are often incorporated into the design of applications that use the OLAP Java API. Each edge contains values of members from one or more dimensions. Although there is no limit to the number of edges on a cube, data is often organized for display purposes along three edges, which are referred to as the row edge, column edge, and page edge.

### **Measures**

Measures contain fact data in a cube. The measure values are organized and identified by dimensions. Measures are usually multidimensional. Each measure value is identified by a unique set of dimension members. This set of dimension members is called a *tuple*.

### **Dimensions**

Dimensions contain lists of unique values that identify and categorize data in a measure. Commonly-used dimensions are customers, products, and times. Typically, a dimension has one or more hierarchies that organize the dimension members into parent-child relationships.

By specifying dimension members, measures, and calculations to perform on the data, end users formulate business questions and get answers to their queries. For example, using a time dimension that categorizes data by month, a product dimension that categorizes data by unit item, and a measure that contains data for the quantities of product units sold by month, you can formulate a query that asks if sales of a product unit were higher in January or in June.

### **Hierarchies**

Hierarchies are components of a dimension that organize dimension members into parent-child relationships. Typically, in the user interface of a client application, an end user can expand or collapse a hierarchy by drilling down or up among the parents and children. The measure values for the parent dimension members are aggregations of the values of the children.

A dimension can have more than one hierarchy. For example, a time dimension could have a calendar year hierarchy and a fiscal year hierarchy. A hierarchy can be level-based or value-based.

In a level-based hierarchy, a parent must be in a higher level than the children of that parent. In a cube, the measure values for the parents are typically aggregated from the values of the children. For example, a time dimension might have levels for year, quarter, and month. The month level contains the base data, which is the most detailed data. The measure value for a quarter is an aggregation of the values of the months that are the children of the quarter and the measure value for a year is the aggregation of the quarters that are children of the year. Typically each level is mapped to a different column in the relational dimension table.

In a value-based hierarchy, the parent and the child dimension members typically come from the same column in the relational table. Another column identifies the parent of a member. For example, a value hierarchy could contain all employees of a company and identify the manager for each employee that has one. All employees, including managers, would come from the same column. Another column would contain the managers of the employees.

### Levels

Levels are components of a level-based hierarchy. A level can be associated with more than one hierarchy. A dimension member can belong to only one level.

A level typically corresponds to a column in a dimension table or view. The base level is the primary key.

### Attributes

Attributes contain information related to the members of a dimension. An end user can use an attribute to select data. For example, an end user might select a set of products by using an attribute that has a descriptive name of each product. An attribute is contained by a dimension.

### Queries

A query is a specification for a particular set of data. The term *query* in the OLAP Java API refers to a `Source` object that specifies a set of data and can include aggregations, calculations, or other operations to perform using the data. The data and the operations on it define the result set of the query. In this documentation, the general term *query* refers to a `Source` object.

The API has a `Query` class in the `oracle.olapi.syntax` package. A `Query` represents a multirow, multicolumn result set that is similar to a relational table, a SQL `SELECT` statement, or an OLAP function. You use a `Query` object in mapping a dimension or measure to a relational table or view.

## 1.1.4 Implementing the Dimensional Data Model

In the OLAP Java API, the dimensional data objects are represented by Multidimensional Model (MDM) classes. These classes are in the `oracle.olapi.metadata.mdm` package. Related classes are in the `oracle.olapi.metadata` package and the other packages under it. For detailed information about those classes, see [Understanding OLAP Java API Metadata](#) (page 2-1).

## 1.1.5 Organizing the Data for OLAP

The OLAP Java API makes it possible for Java applications (including applets) to access data that resides in an Oracle data warehouse. A data warehouse is a relational database that is designed for query and analysis, rather than for transaction processing. Warehouse data often conforms to a star schema, which is a dimensional data model for a relational database. A star schema consists of one or more fact tables and one or more dimension tables. The fact tables have columns that contain foreign keys to the dimension tables. Typically, a data warehouse is created from a transaction processing database by an extraction transformation transport (ETT) tool.

For the data in a data warehouse to be accessible to an OLAP Java API application, a database administrator must ensure that the data warehouse is configured according to an organization that is supported by Oracle OLAP. The star schema is one such organization, but not the only one. See *Oracle OLAP User's Guide* for information about supported data warehouse configurations.

Once the data is organized in the warehouse, you can use an OLAP Java API application to design an OLAP dimensional data model of cubes, measures, dimensions, and so on, and to create the logical OLAP metadata objects that implement the model. You map the metadata objects to data in the warehouse and build an analytic workspace. Building the analytic workspace populates the OLAP

views and other storage structures with the data that the OLAP metadata objects represent.

You can also use Analytic Workspace Manager to do the same tasks. See *Oracle OLAP User's Guide* for information about creating an analytic workspace with Analytic Workspace Manager.

An OLAP Java API application can get the OLAP metadata objects created either by Analytic Workspace Manager or through the OLAP Java API. It can use the metadata objects to create queries that operate on the data in the warehouse.

The collection of warehouse data in an analytic workspace is the data store to which the OLAP Java API gives access. Of course, the scope of the data that a user has access to is limited by the privileges granted to the user by the database administrator.

In addition to ensuring that data and metadata have been prepared appropriately, you must ensure that application users can make a JDBC connection to the data store and that users have database privileges that give them access to the data. For information about specifying privileges, see *Oracle OLAP User's Guide*. For information about establishing a connection, see [Discovering Metadata](#) (page 3-1).

## 1.2 Accessing Data Through the OLAP Java API

Oracle OLAP metadata objects organize and describe the data that is available to a client application. The metadata objects contain other information, as well, such as the data type of the data. However, you cannot retrieve data directly from a metadata object. To specify the data that you want, you must create a query. In specifying the data, you usually must specify one or more dimension member values. To retrieve the specified data, you create a `Cursor`. This topic briefly describes those actions.

Another way that you can query the data contained in OLAP metadata objects is through SQL queries of the views that Oracle OLAP creates for the metadata objects. For information about querying these views, see "[Using OLAP Views](#) (page 2-28)" in [Understanding OLAP Java API Metadata](#) (page 2-1).

### 1.2.1 Creating Queries

Queries are represented by `oracle.olapi.data.source.Source` objects. You get a `Source` from a metadata object and use that `Source` object in specifying the data that you want to get. `Source` classes have methods for selecting and performing operations on the data. You can use the methods to manipulate data in any way that the user requires. For information about `Source` objects, see [Understanding Source Objects](#) (page 5-1) and [Making Queries Using Source Methods](#) (page 6-1).

### 1.2.2 Specifying Dimension Members

The members of an Oracle OLAP dimension are usually organized into one or more hierarchies. Some hierarchies have parent-child relationships based on levels and some have those relationships based on values. The value of each dimension member must be unique.

The OLAP Java API uses a three-part format to uniquely identify a dimension member. The format contains the hierarchy, the level, and the value of the dimension member, and thereby identifies a unique value in the dimension. The first part of a unique value is the name of the hierarchy object, the second part is the name of the level object, and the third part is the value of the member in the level. The parts of the unique value are separated by a value separation string, which by default is double

colons (: :). The following is an example of a unique member value of a level named YEAR in a hierarchy named CALENDAR\_YEAR in a dimension named TIME\_AWJ.

```
CALENDAR_YEAR::YEAR::CY2001
```

The third part of a unique value is the local value. The local value in the preceding example identifies the calendar year 2001.

### 1.2.3 Creating Cursors

To retrieve the data specified by a `Source`, you create an `oracle.olapi.data.cursor.Cursor` for that `Source`. You then use this `Cursor` to request and retrieve the data from the data store. You can specify the amount of data that the `Cursor` retrieves in each fetch operation (for example, enough to fill a 40-cell table in the user interface). Oracle OLAP then efficiently manages the timing, sizing, and caching of the data blocks that it retrieves for your application, so that you do not need to do so. For information about `Cursor` objects, see [Understanding Cursor Classes and Concepts](#) (page 8-1) and [Retrieving Query Results](#) (page 9-1).

## 1.3 Sample Schema for OLAP Java API Examples

The examples of OLAP Java API code in this documentation are excerpts from a set of example programs that are available on the Oracle Technology Network (OTN) website. One example, `CreateAndBuildAW.java`, has methods that create and build an analytic workspace. Another example, `SpecifyAWValues`, calls the methods of `CreateAndBuildAW.java` and specifies values, such as names for the metadata objects and names of columns of relational tables for mapping the metadata objects to data sources. The analytic workspace produced by these examples is named `GLOBAL_AWJ`. Other examples query that analytic workspace. The metadata objects in the analytic workspace are mapped to columns in relational tables that are in the Global schema.

From the OTN website, you can download a file that contains SQL scripts that create the Global schema and a file that contains the example programs. The OTN website is at <http://www.oracle.com/technetwork/database/options/olap/index.html>.

To get either file, select **Sample Code and Schemas** in the Download section of the web page. To get the sample schema, select **Global Schema 11g**. To get the example programs, select **Example Programs for Documentation** and then select Download the **Example Programs for 11g Release 2 (11.2)** to download the compressed file that contains the examples.

The example programs are in a package structure that you can easily add to your development environment. The classes include a base class that the example program classes extend, and utility classes that they use. The base class is `BaseExample11g.java`. The utility classes include `Context11g.java` and `CursorPrintWriter.java`. The `Context11g.java` class has methods that create a connection to an Oracle Database instance, that store metadata objects, that return the stored metadata objects, and that create `Cursor` objects. The `CursorPrintWriter.java` class is a `PrintWriter` that has methods that display the contents of `Cursor` objects.

The OLAP metadata objects are created and built by the `CreateAndBuildAW.java` and the `SpecifyAWValues` programs. Those metadata objects include the following:

- `GLOBAL_AWJ`, which is the analytic workspace that contains the other objects.

- `PRODUCT_AWJ`, which is a dimension for products. It has one hierarchy named `PRODUCT_PRIMARY`. The lowest level of the hierarchy has product item identifiers and the higher levels have product family, class, and total products identifiers.
- `CUSTOMER_AWJ`, which is a dimension for customers. It has two hierarchies named `SHIPMENTS` and `MARKETS`. The lowest level of each hierarchy has customer identifiers and higher levels have warehouse, region, and total customers, and account, market segment, and total market identifiers, respectively.
- `TIME_AWJ`, which is a dimension for time values. It has a hierarchy named `CALENDAR_YEAR`. The lowest level has month identifiers, and the other levels have quarter and year identifiers.
- `CHANNEL_AWJ`, which is a dimension for sales channels. It has one hierarchy named `CHANNEL_PRIMARY`. The lowest level has sales channel identifiers and the higher level has the total channel identifier.
- `UNITS_CUBE_AWJ`, which is a cube that contains the measures `COST`, `SALES`, and `UNITS`. `COST` has values for the costs of product units. `SALES` has the dollar amounts for the sales of product units. `UNITS` has values for the quantities of product units sold. The cube is dimensioned by all four dimensions. The aggregation method for the cube is `SUM`, in which each the value for each parent is the sum of the values of the children of the parent.
- `PRICE_CUBE_AWJ`, which is a cube that contains the measures `UNIT_COST` and `UNIT_PRICE`. `UNIT_COST` has the costs of the units. `UNIT_PRICE` has the prices of the units. The cube is dimensioned by the `PRODUCT_AWJ` and `TIME_AWJ` dimensions. The aggregation method for the cube is `AVG`, in which the value for each parent is the average of the values of the children of the parent.

For an example of a program that discovers the OLAP metadata for the analytic workspace, see [Discovering Metadata](#) (page 3-1).

## 1.4 Tasks That an OLAP Java API Application Performs

A client application that uses the OLAP Java API typically performs the following tasks:

1. Connects to the data store and creates a `DataProvider` and a `UserSession`.
2. Creates or discovers metadata objects.
3. Deploys, maps, and builds metadata objects, as needed.
4. Specifies queries that select and manipulate data.
5. Retrieves query results.

The rest of this topic briefly describes these tasks, and the rest of this guide provides detailed information about how to accomplish them.

### Task 1: Connect to the Data Store and Create a `DataProvider` and `UserSession`

You connect to the data store by identifying some information about the target Oracle Database instance and specifying this information in a JDBC connection method. Having established a connection, you create a `DataProvider` and use it and the connection to create a `UserSession`. For more information about connecting and

creating a `DataProvider` and `UserSession`, see "[Connecting to Oracle OLAP](#) (page 3-1)" in [Discovering Metadata](#) (page 3-1).

### Task 2: Create or Discover Metadata Objects

You use the `DataProvider` to get an `MdmMetadataProvider`. The `MdmMetadataProvider` gives access to all of the metadata objects in the data store. You next obtain the `MdmRootSchema` object by calling the `getRootSchema` method of the `MdmMetadataProvider`. The `MdmRootSchema` object contains all of the OLAP metadata objects in the database. From the `MdmRootSchema`, you get the `MdmDatabaseSchema` objects for the schemas that the current user has permission to access. An `MdmDatabaseSchema` represents a named Oracle Database user as returned by the SQL statement `SELECT username FROM all_users`.

From an `MdmDatabaseSchema`, you can discover the existing metadata objects that are owned by the schema or you can create new ones. Methods such as `getMeasures` and `getDimensions` get all of the measures or dimensions owned by the `MdmDatabaseSchema`. Methods such as `findOrCreateAW` and `findOrCreateCube` get an analytic workspace or cube, if it exists, or create one if it does not already exist.

From a top-level metadata object contained by the `MdmDatabaseSchema`, such as an analytic workspace, cube, or dimension, you can get the objects that it contains. For example, from an `MdmPrimaryDimension`, you can get the hierarchies, levels, and attributes that are associated with it. Having determined the metadata objects that are available to the user, you can present relevant lists of objects to the user for data selection and manipulation.

For a description of the metadata objects, see [Understanding OLAP Java API Metadata](#) (page 2-1). For information about how you can discover the available metadata, see [Discovering Metadata](#) (page 3-1).

### Task 3: Deploy, Map, and Build Objects

If you create a new `MdmCube` or `MdmPrimaryDimension`, you must deploy it as an analytic workspace object or as a relational OLAP (Rolap) object. To deploy a cube, you call an `MdmCube` method such as `findOrCreateAWCubeOrganization`. To deploy a dimension, you call an `MdmPrimaryDimension` method such as `findOrCreateAWPrimaryDimensionOrganization`.

If you create a new metadata object that represents data, you must specify an `Expression` that maps the metadata object to a relational source table or view, or that Oracle OLAP uses to generate the data. For objects that are contained by an analytic workspace, you can build the metadata objects after mapping them. For information on creating metadata, deploying, mapping, and building metadata objects, see [Creating Metadata and Analytic Workspaces](#) (page 4-1).

### Task 4: Select and Calculate Data Through Queries

An OLAP Java API application can construct queries against the data store. A typical application user interface provides ways for the user to select data and to specify the operations to perform using the data. Then, the data manipulation code translates these instructions into queries against the data store. The queries can be as simple as a selection of dimension members, or they can be complex, including several aggregations and calculations involving the measure values that are specified by selections of dimension members.

The OLAP Java API object that represents a query is a `Source`. Metadata objects that represent data are extensions of the `MdmSource` class. From an `MdmSource`, such as an `MdmMeasure` or an `MdmPrimaryDimension`, you can get a `Source` object. With the methods of a `Source` object, you can produce other `Source` objects that specify a

selection of the elements of the `Source`, or that specify calculations or other operations to perform on the values of a `Source`.

If you are implementing a simple user interface, then you might use only the methods of a `Source` object to select and manipulate the data that users specify in the interface. However, if you want to offer your users multistep selection procedures and the ability to modify queries or undo individual steps in their selections, then you should design and implement `Template` classes. Within the code for each `Template`, you use the methods of the `Source` classes, but the `Template` classes themselves allow you to dynamically modify and refine even the most complex query. In addition, you can write general-purpose `Template` classes and reuse them in various parts of your application.

For information about working with `Source` objects, see [Understanding Source Objects](#) (page 5-1). For information about working with `Template` objects, see [Creating Dynamic Queries](#) (page 10-1).

### **Task 5: Retrieve Query Results**

When users of an OLAP Java API application are selecting, calculating, combining, and generally manipulating data, they also want to see the results of their work. This means that the application must retrieve the result sets of queries from the data store and display the data in multidimensional form. To retrieve a result set for a query through the OLAP Java API, you create a `Cursor` for the `Source` that specifies the query.

You can also get the SQL that Oracle OLAP generates for a query. To do so, you create a `SQLCursorManager` for the `Source` instead of creating a `Cursor`. The `generateSQL` method of the `SQLCursorManager` returns the SQL specified by the `Source`. You can then retrieve the data by means outside of the OLAP Java API.

Because the OLAP Java API was designed to deal with a multidimensional view of data, a `Source` can have a multidimensional result set. For example, a `Source` can represent an `MdmMeasure` that is dimensioned by four `MdmPrimaryDimension` objects. Each `MdmPrimaryDimension` has an associated `Source`. You can create a query by joining the `Source` objects for the dimensions to the `Source` for the measure. The resulting query has the `Source` for the measure as the base and it has the `Source` objects for the dimensions as outputs.

A `Cursor` for a query `Source` has the same structure as the `Source`. For example, the `Cursor` for the `Source` just mentioned has base values that are the measure data. The `Cursor` also has four outputs. The values of the outputs are those of the `Source` objects for the dimensions.

To retrieve all of the items of data through a `Cursor`, you can loop through the multidimensional `Cursor` structure. This design is well adapted to the requirements of standard user interface objects for painting the computer screen. It is especially well adapted to the display of data in multidimensional format.

For more information about using `Source` objects to specify a query, see [Understanding Source Objects](#) (page 5-1). For more information about using `Cursor` objects to retrieve data, see [Understanding Cursor Classes and Concepts](#) (page 8-1). For more information about the `SQLCursorManager` class, see *Oracle OLAP Java API Reference*.



---

# Understanding OLAP Java API Metadata

This chapter describes the classes in the Oracle OLAP Java API that represent OLAP dimensional and relational metadata objects. It also describes the classes that provide access to the metadata objects and to data sources, or that contain information about the metadata objects. This chapter includes the following topics:

- [Overview of OLAP Java API Metadata Classes](#) (page 2-1)
- [Identifying, Describing, and Classifying Metadata Objects](#) (page 2-3)
- [Providing Metadata Objects](#) (page 2-9)
- [Providing Access to Data Sources](#) (page 2-15)

For more information on getting existing metadata objects, see [Discovering Metadata](#) (page 3-1). For more information on creating metadata objects, see [Creating Metadata and Analytic Workspaces](#) (page 4-1).

## 2.1 Overview of OLAP Java API Metadata Classes

[Introduction to the OLAP Java API](#) (page 1-1) describes the OLAP dimensional data model and briefly mentions some of the OLAP Java API classes that implement that model. Those classes are in the `oracle.olapi.metadata` packages. Using those classes, you can do the following tasks.

- Gain access to the available metadata objects
- Create new metadata objects
- Deploy metadata objects in an analytic workspace or as relational objects
- Map metadata objects to data sources
- Export metadata objects to XML or import them from XML
- Create Source objects to query the data

[Figure 2-1](#) (page 2-2) shows the `oracle.olapi.metadata` packages.

**Figure 2-1 The oracle.olapi.metadata Packages**

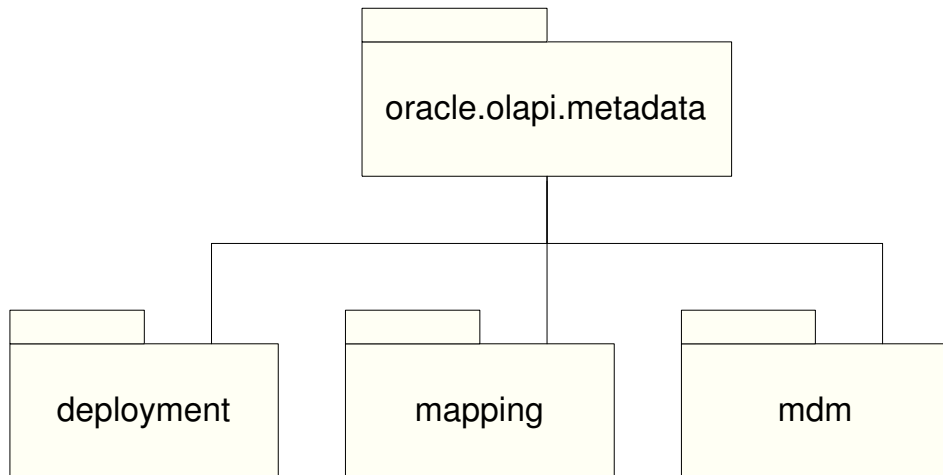

The packages are the following:

- `oracle.olapi.metadata`, which has interfaces and abstract classes that specify the most basic characteristics of metadata objects and metadata providers.
- `oracle.olapi.metadata.mdm`, which has classes that implement the MDM (multidimensional model) metadata model. This package has classes that represent the metadata objects, classes that provide access to those objects, and classes that contain descriptive information about the objects.
- `oracle.olapi.metadata.deployment`, which has classes that specify the organization of a metadata object as an analytic workspace object or as a relational object.
- `oracle.olapi.metadata.mapping`, which has classes that map a metadata object to relational data sources.

Some of the classes in the `oracle.olapi.metadata.mdm` package directly correspond to OLAP dimensional metadata objects. [Table 2-1](#) (page 2-2) presents some of these correspondences.

**Table 2-1 Corresponding Dimensional and MDM Objects**

Dimensional Metadata Objects	MDM Metadata Objects
Cube	MdmCube
Measure	MdmBaseMeasure
Calculated measure	MdmDerivedMeasure
Measure folder	MdmOrganizationalSchema
Dimension	MdmTimeDimension and MdmStandardDimension
Hierarchy	MdmLevelHierarchy and MdmValueHierarchy
Level	MdmDimensionLevel and MdmHierarchyLevel

**Table 2-1 (Cont.) Corresponding Dimensional and MDM Objects**

Dimensional Metadata Objects	MDM Metadata Objects
Attribute	MdmBaseAttribute and MdmDerivedAttribute

Other classes in the package correspond to relational objects. [Table 2-2](#) (page 2-3) shows those correspondences.

**Table 2-2 Corresponding Relational and MDM Objects**

Relational Objects	MDM Metadata Objects
Schema	MdmDatabaseSchema
Table	MdmTable
Table column	MdmColumn

## 2.2 Identifying, Describing, and Classifying Metadata Objects

Most OLAP Java API metadata objects have a unique identifier (ID), a name, and an owner or a containing object. You can also associate descriptions and classifications to most metadata objects.

Most metadata classes extend the abstract `oracle.olapi.metadata.BaseMetadataObject` class. A `BaseMetadataObject` can have a name and an ID. You can get most metadata objects by name. The ID is used internally by Oracle OLAP, but an application can also use the ID to get some metadata objects.

A `BaseMetadataObject` also has an owner, which is returned by the `getOwner` method. For most metadata objects, the owner is an `MdmDatabaseSchema`. For the `MdmRootSchema` and `MdmMeasureDimension` objects, the owner is the root schema. For an `MdmViewColumn`, which is not a subclass of `BaseMetadataObject`, the `getOwner` method returns the owning implementation of the `MdmViewColumnOwner` interface, such as an `MdmPrimaryDimension`, an `MdmBaseAttribute`, or an `MdmMeasure`. An `MdmViewColumn` represents a column in an OLAP view. For information on OLAP views, see "[Using OLAP Views](#) (page 2-28)".

Some `BaseMetadataObject` objects are contained by the metadata object that created them. For example, an `MdmBaseMeasure` is contained by the `MdmCube` that created it. You can get the container for a metadata object by calling the `getContainedByObject` method.

The `MdmObject` class, which is an abstract subclass of `BaseMetadataObject`, adds associations with descriptive objects and classifications. Typically, a descriptive object contains a name or descriptive text that you associate with the metadata object itself. Applications often use a descriptive object for display purposes in a user interface. A classification is a string value that your application assigns to the metadata object. Your application handles the classification for whatever purpose you want.

### 2.2.1 Identifying Objects

You can identify a `BaseMetadataObject` object by name and by ID. Namespaces identify the type and the format of legacy metadata objects.

### 2.2.1.1 Getting and Setting Names

Most metadata objects have a name that you can get by calling the `getName` method of the object. For some objects, you can assign a name when you create the object. For example, an `oracle.olapi.metadata.deployment.AW` object represents an analytic workspace. When you create an AW by calling the `findOrCreateAW` method of an `MdmDatabaseSchema`, you use the `publicName` parameter of the method to specify a name for the AW object that the method returns.

For some objects, you can use the `setName` method to change the name of an existing object. For example, you can change the name of an `MdmStandardDimension` by calling the `setName` method of the dimension object. The new name does not take effect until you commit the root `Transaction` of the session. After you call `setName`, but before you commit the root `Transaction`, the `getNewName` method returns the new name while the `getName` method returns the existing name. For more information on getting objects by name, see "[About Creating a Metadata Object or a Query in a Transaction](#) (page 7-1)"

You can get some objects by name from an `MdmDatabaseSchema`. For more information on getting objects by name, see "[Representing Schemas](#) (page 2-12)".

For use in displaying names or descriptions in a user interface, or for any purpose you want, you can associate any number of names and descriptions with an `MdmObject` by using the `MdmDescription` class. For information on using that class, see "[Using Descriptions](#) (page 2-6)".

### 2.2.1.2 Describing Unique Identifiers

Most metadata objects have a unique identifier (ID). The identifier has one of the following forms.

- `objectName`
- `ownerName.objectName`
- `ownerName.containerName.objectName`

For example, for the `MdmDatabaseSchema` that represents the schema for the user `GLOBAL`, the identifier returned by the `getID` method is `GLOBAL`. For an `MdmPrimaryDimension` named `PRODUCT_AWJ`, the `getID` method returns `GLOBAL.PRODUCT_AWJ` and for an `MdmLevelHierarchy` of that dimension named `PRODUCT_PRIMARY`, the method returns `GLOBAL.PRODUCT_AWJ.PRODUCT_PRIMARY`.

The ID of a metadata object is persistent. However, if the name or the owner of a metadata object changes, then the ID changes as well. For more information on getting objects by ID, see "[Getting Metadata Objects by ID](#) (page 2-9)".

For a legacy 10g metadata object, the first part of the identifier is a namespace. The namespace is followed by the namespace delimiter, which is two periods. An example of the identifier of a 10g dimension is `AWXML_DIMENSION..GLOBAL.PRODUCT_AW`.

### 2.2.1.3 Supporting Legacy Metadata Objects

In Oracle Database, Release 11g, Oracle Database, Release 11g Oracle OLAP supports legacy 10g OLAP Java API applications. Namespaces identify 10g metadata objects and enable them to exist in the same session as 11g objects.

### 2.2.1.3.1 Supporting Legacy Applications

To support legacy applications that use OLAP metadata objects that were created in 10g, the `oracle.olapi.data.source.DataProvider` class has a metadata reader mode. By default, the metadata reader recognizes Oracle OLAP 10g and 11g metadata objects. You can specify a metadata reader mode with a property of a `java.util.Properties` object or with a string in the proper XML format. For information on the modes and how to specify one, see the constructor methods of the `DataProvider` class in the *Oracle OLAP Java API Reference* documentation.

### 2.2.1.3.2 Describing Namespaces

In Oracle Database, Release 10g, an Oracle OLAP cube, dimension, or measure folder could have the same name as a relational table or view. In Release 11g, top-level OLAP metadata objects are stored in the Oracle Database data dictionary, so they cannot have the same name as another relational object. A namespace designation allows a legacy OLAP Java API 10g metadata object to exist in the same session as 11g metadata objects. Such legacy metadata objects were created by using classes in the `oracle.olapi.AWXML` package of the Oracle OLAP Analytic Workspace Java API or by using CWM PL/SQL packages. For 10g and 11g objects to exist in the same session, the metadata reader mode of the `DataProvider` must be set to `ALL`. The `ALL` mode is the default metadata reader mode. For more information on metadata reader mode settings, see the `DataProvider` class documentation in *Oracle OLAP Java API Reference*.

The metadata objects for a 10g cube, dimension, and measure folder are represented in 11g by the `MdmCube`, `MdmPrimaryDimension`, and `MdmSchema` classes. An instance of one of those classes can have a namespace associated with it, which is returned by the `getNamespace` method. For an 11g object, the namespace is null.

The 11g XML definition of a 10g object has a `Namespace` attribute. For information on exporting and importing XML definitions of metadata objects, see "[Exporting and Importing Metadata as XML Templates](#) (page 2-10)".

The namespace of a legacy metadata object identifies the metadata format and the type of object. It begins with either `AWXML_` or `CWM_` and then has the type of object, such as `CUBE` or `DIMENSION`. For example, a dimension created by using the Oracle OLAP Analytic Workspace Java API in Oracle Database 10g, Release 2 (10.2), would have the namespace `AWXML_DIMENSION` in 11g.

The valid namespaces are represented by static constant fields of the `MdmMetadataProvider` class. The `getValidNamespaces` method of that class returns a list of the valid namespaces, including the default namespace. You cannot create a new namespace.

You can use the constant fields to get a legacy metadata object from an `MdmDatabaseSchema`. For example, the following code gets the `PRODUCT_AW` dimension. In the code, `mdmDBSchema` is the `MdmDatabaseSchema` for the `GLOBAL` user.

```
MdmStandardDimension mdmProdAWDim =
    mdmDBSchema.findOrCreateStandardDimension("PRODUCT_AW",
        MdmMetadataProvider.AWXML_DIMENSION_NAMESPACE);
```

In the `ALL` metadata reader mode, you get an existing 10g metadata object but you cannot create a new one. If the legacy metadata object does not exist, the method returns an 11g object that has the specified name.

## 2.2.2 Using Descriptions

With an `MdmDescription` object, you can associate descriptive information with an `MdmObject` object.

An `MdmDescriptionType` object represents the type of description of an `MdmDescription`. You can use `MdmDescription` objects to display names, descriptions, or other information for a metadata object in a user interface. `MdmDescription` objects are created, assigned, and handled entirely by your application.

---

---

**Note:**

A descriptive name that you associate with an `MdmObject` through an `MdmDescription` is not the object name that is returned by the `MdmObject.getName` method. The object name is used by Oracle OLAP to identify the object internally. A descriptive name is used only by an application.

---

---

The OLAP Java API defines some types of descriptions. The `MdmDescriptionType` class has static methods that provide the following description types:

- Name
- Short name
- Long name
- Plural name
- Short plural name
- Long plural name
- Description
- Short description
- Long description

You get one of these defined description types by calling a method of `MdmDescriptionType`. For example, the following code gets the description type object for a long name and a long description.

```
MdmDescriptionType mdmLongNameDescrType =  
    MdmDescriptionType.getLongNameDescriptionType();  
MdmDescriptionType mdmLongDescrDescrType =  
    MdmDescriptionType.getLongDescriptionDescriptionType();
```

You can create a new type of description by using a constructor method of `MdmDescriptionType`. You can get the type of an `MdmDescriptionType` object with the `getDescriptiveType` method. The first figure below shows the methods of `MdmDescriptionType`.

Some of the defined description types have an associated default description type. You change a default description type or assign a default description type for a new or existing `MdmDescriptionType` by using the

`MdmDescriptionType(java.lang.String type, MdmDescriptionType defaultType)` constructor method. You can get the default type of an `MdmDescriptionType` object with the `getDescriptiveTypeDefault` method.

### **Example 2-1 Associating a Description with an MdmObject**

To associate an `MdmDescription` object with an `MdmObject`, use the `findOrCreateDescription` or a `setDescription` method of the `MdmObject`. The `findOrCreateDescription` method returns an `MdmDescription` object. To specify a value for the description, use the `setValue` method of `MdmDescription`.

This example shows both ways of associating an `MdmDescription` with an `MdmObject`. In the example, `mdmProdDim` is an `MdmStandardDimension` object.

```
MdmDescription mdmShortNameDescr =
    mdmProdDim.findOrCreateDescription(
        MdmDescriptionType.getShortNameDescriptionType(), "AMERICAN");
mdmShortNameDescr.setValue("Product");

mdmProdDim.setDescription(
    MdmDescriptionType.getLongNameDescriptionType(), "Product Dimension");
```

This figure shows the methods of `MdmObject` that use `MdmDescription` and `MdmDescriptionType` objects. It also shows the `MdmDescription` and `MdmDescriptionType` classes and their methods, and the associations between the classes. An `MdmObject` can have from zero to many `MdmDescription` objects. An `MdmDescription` is associated with one `MdmObject` and one `MdmDescriptionType`. An `MdmDescriptionType` can be associated with one or more `MdmDescription` objects.

**Figure 2-2 MdmObject and MdmDescription Associations**



Versions of the OLAP Java API before 11g did not have the `MdmDescription` and `MdmDescriptionType` classes. In those versions, the `MdmObject` class had only the following methods for getting and setting descriptions.

**Figure 2-3 Methods for Getting and Setting Descriptions Before 11g**

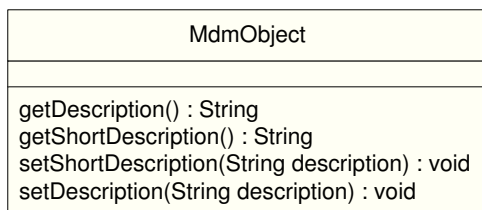

For backward compatibility, the OLAP Java API still supports these methods, but implements them internally using `MdmDescription` and `MdmDescriptionType` objects.

### 2.2.3 Using Classifications

A classification is a property of an `MdmObject`. You assign a classification to an object and then use the classification as you please. For example, you could add a classification with the value of "HIDDEN" to indicate that an application should not display the object in the user interface. You can assign a classification to an `MdmObject` by using the `addObjectClassification` method of the object. You



can get the classifications with the `getObjectClassifications` method and remove one with the `removeObjectClassification` method.

## 2.3 Providing Metadata Objects

Access to Oracle OLAP Java API metadata objects is initially provided by an `MdmMetadataProvider` and by `MdmSchema` objects. The `MdmMetadataProvider` also has the ability to import or export an XML representation of a metadata object. The following topics describe the `MdmMetadataProvider` class and its uses.

- [Describing Metadata Providers](#) (page 2-9)
- [Representing Schemas](#) (page 2-12)

### 2.3.1 Describing Metadata Providers

Before you can get or create OLAP Java API metadata objects, you must first create an `MdmMetadataProvider`. For information on creating an `MdmMetadataProvider`, see "[Creating an MdmMetadataProvider](#) (page 3-4)".

With the `getRootSchema` method of the `MdmMetadataProvider`, you can get the root `MdmSchema` object, which is an instance of the `MdmRootSchema` class. The root schema is a container for `MdmDatabaseSchema` objects.

`MdmDatabaseSchema` objects are owners of top-level metadata objects such as `AW`, `MdmCube`, and `MdmPrimaryDimension` objects. The top-level objects are first-class data objects and are represented in the Oracle Database data dictionary. Because they are in the data dictionary, these OLAP data objects are available to SQL queries. You create top-level metadata objects by using `findOrCreate` methods of an `MdmDatabaseSchema`.

The top-level objects are the containers of objects such as `MdmMeasure`, `MdmHierarchy`, and `MdmAttribute` objects. You create the contained objects by using methods of the top-level objects.

For more information on `MdmSchema` objects, see "[Representing Schemas](#) (page 2-12)". For information on top-level metadata objects, see "[Providing Access to Data Sources](#) (page 2-15)".

You can also get an existing metadata object by calling the `getMetadataObject` or `getMetadataObjects` method of the `MdmMetadataProvider` and providing the ID of the metadata object.

The following topics describe getting metadata objects:

- [Getting Metadata Objects by ID](#) (page 2-9)
- [Exporting and Importing Metadata as XML Templates](#) (page 2-10)

#### 2.3.1.1 Getting Metadata Objects by ID

Usually, you get or create metadata objects by calling `findOrCreate` methods on the owning object. For example, you can get or create an `MdmCube` by calling the `findOrCreateCube` method of an `MdmDatabaseSchema` object. However, you can also get an existing metadata object from an `MdmMetadataProvider` by specifying the ID of the object. The `MdmMetadataProvider.getMetadataObject` method takes a `String` that is the ID of an object and returns the object. The `getMetadataObjects` method takes a `List` of IDs and returns a `List` of objects.

You can store the ID of a metadata object from one session and then get the object by that ID in another session. Of course, getting an object by a stored ID assumes that the object still exists and that the ID of the object has not changed. For some metadata objects, you can change the name or the owner. If the name or owner of the object changes, then the ID of the object changes.

### 2.3.1.2 Exporting and Importing Metadata as XML Templates

The `MdmMetadataProvider` class has many methods for exporting and importing metadata objects to and from XML definitions of those objects. The XML definition is a template from which Oracle OLAP can create the metadata objects defined.

You can use XML templates to transport metadata objects between Oracle Database instances. You can exchange XML templates between Analytic Workspace Manager and an OLAP Java API application; that is, in Analytic Workspace Manager you can import a template that you created with an `MdmMetadataProvider` `exportXML` method, and you can use an `importXML` method to import an XML template created by Analytic Workspace Manager.

When exporting XML, you can rename objects or specify bind variables for the values of XML attributes. You can also supply an implementation of the `XMLWriterCallback` interface to manage some aspects of the export process. When importing XML, you can specify an `MdmDatabaseSchema` to own the imported objects, bind values to replace the bind variables in the exported XML, and an implementation of the `XMLParserCallback` interface to manage some aspects of the import process.

The following topics describe exporting and importing metadata objects through XML templates.

- [Exporting XML Templates](#) (page 2-10)
- [Importing XML Templates](#) (page 2-11)
- [Describing Bind Variables in XML Templates](#) (page 2-12)

#### 2.3.1.2.1 Exporting XML Templates

For exporting metadata objects to XML templates, `MdmMetadataProvider` has many signatures of the `exportFullXML` and `exportIncrementalXML` methods. The methods export a template to a `java.lang.String` or to a `java.io.Writer`.

You can use an XML template produced by these methods to import metadata objects through the `importXML` methods of `MdmMetadataProvider`. You can also use the XML template to import metadata objects in Analytic Workspace Manager.

An `exportFullXML` method exports the complete XML definitions for the specified objects or for the objects that you have created or modified since a specified `oracle.olapi.transaction.Transaction`. For an example of using the `exportFullXML` method, see [Example 4-10](#) (page 4-11).

An `exportIncrementalXML` method exports only the XML attributes that have changed for a metadata object since a specified `Transaction`. If you specify a `List` of objects, then the exported templates contain the XML attributes that have changed for the objects that are in the list. The exported incremental XML includes the type and name of the objects in the ownership and containment hierarchy of the changed object.

The `exportFullXML` and `exportIncrementalXML` methods take various combinations of the following parameters.

- A `List` of the objects to export or a `Transaction`.

- A `Writer` to which Oracle OLAP exports the XML. If you do not specify a `Writer`, then the method returns a `java.lang.String` that contains the XML.
- A `java.util.Map` that has metadata object references as keys and that has, as the objects for the keys, `String` values that contain new names for the referenced objects. With this `Map`, you can rename an object that you export. You can specify `null` for the parameter if you do not want to rename any objects.

If you specify a `Map` for this `renameMap` parameter, then the Oracle OLAP XML generator renames a referenced object during the export. You can copy the definition of an existing object this way, by renaming an object during the export of an XML template and then importing the template.

- A `boolean` that specifies whether or not to include the name of the owning object in the exported XML.
- An optional `Map` that has metadata object references as keys and that has, as the objects for the keys, `String` values that function like SQL bind variables. For more information on the bind variables in this parameter, see "[Describing Bind Variables in XML Templates](#) (page 2-12)".
- An optional implementation of the `oracle.olapi.metadata.XMLWriterCallback` interface. With an `XMLWriterCallback`, you can specify whether or not to exclude an attribute or an owner name from the exported XML.

All metadata objects that share an ancestor are grouped together in the exported XML. For any object that is not a top-level object and whose top-level container is not in the `List` of the objects to export, the exported template contains an incremental definition to the object and a full definition below that. This supports the export of objects such as a calculated measure in a cube without having to export the entire cube template.

If an `MdmDatabaseSchema` is in the `List` of objects to export, then the exported template includes all objects within the database schema. If an `oracle.olapi.metadata.deployment.AW` object is in the `List`, then the exported template includes all of the objects that are contained by the `AW`. If the `MdmRootSchema` is in the list, it is ignored.

### 2.3.1.2.2 Importing XML Templates

For importing metadata objects as XML templates, `MdmMetadataProvider` has several signatures of the `importXML` method.

An `importXML` method imports XML definitions of objects and either creates new objects or modifies existing objects. The `importXML` method take various combinations of the following parameters.

- A `java.io.Reader` for input of the XML or a `String` that contains the XML to import.
- An `MdmDatabaseSchema` to contain the new or modified metadata objects.
- A `boolean`, `modifyIfExists`, that indicates whether or not you want differences in the imported XML definition to modify an existing object of the same name.
- An optional `Map`, `bindValues`, that contains bind variables as keys and, as the objects for the keys, `String` values to replace the bind variables. For more information on the bind values in this parameter, see "[Describing Bind Variables in XML Templates](#) (page 2-12)".

- An optional implementation of the `oracle.olapi.metadata.XMLParserCallback` interface.

If the value of the `modifyIfExists` parameter is `true` and if the imported XML contains a full definition for an object that already exists and the object definition is different from the XML, then the method merges the new or changed elements of the object definition with the existing definition of the object. If the value of `modifyIfExists` is `false` and if the XML contains a full definition for an object that already exists, then the `importXML` method throws an exception.

With the `bindValues` parameter, you can specify a `Map` that has key/object pairs that Oracle OLAP uses to replace bind variables when importing an XML template. A key in the `Map` is a bind variable to replace and the object paired to the key is the value with which to replace the bind variable. When you import a template, if you specify a `Map` that contains bind variables as keys, then Oracle OLAP replaces a bind variable in the imported XML with the value specified for the bind variable in the `bindValues` `Map`.

You can pass an implementation of the `XMLParserCallback` interface to an `importXML` method as the `parserCallback` parameter. With the `XMLParserCallback`, you can specify how Oracle OLAP handles an error that might occur when importing XML. The `XML11_2_ParserCallback` interface adds methods for renaming the imported object and for suppressing attributes of the imported object.

### 2.3.1.2.3 Describing Bind Variables in XML Templates

The `exportFullXML` and `exportIncrementalXML` methods have an optional `bindVariables` parameter. This parameter is a `Map` that has metadata objects as keys and `String` values as the objects for the keys. The `String` values function like SQL bind variables. During the export of the XML, the Oracle OLAP XML generator replaces the name of the referenced object with the bind variable.

If you provide a `Map` for the `bindVariables` parameter to an `exportFullXML` or `exportIncrementalXML` method, then the XML produced by the method begins with the following declaration.

```
<!DOCTYPE Metadata [
<ENTITY % BIND_VALUES PUBLIC "OLAP BIND VALUES" "OLAP METADATA">
%BIND_VALUES;
]>
```

A value specified in the `bindVariables` map appears in the exported XML in the format "`&BV;`", where `BV` is the bind variable.

The `bindValues` parameter of an `importXML` method specifies values that Oracle OLAP uses to replace the bind variables when importing an XML template. When you import a template, if you specify a `Map` that contains bind variables as keys, then Oracle OLAP replaces a bind variable in the imported XML with the `String` specified as the object for the bind variable key in the `Map`.

If you provide a `Map` for the `bindValues` parameter, then the `inXML` string that you provide to the method must include the `!DOCTYPE Metadata` declaration and the bind variables in the XML to import must be in the "`&BV;`" format.

## 2.3.2 Representing Schemas

Schemas are represented by the `MdmSchema` class and the subclasses of it. An `MdmSchema` is owner of, or a container for, `MdmCube`, `MdmDimension`, and other

MdmObject objects, including other MdmSchema objects. In the 10g and earlier versions of the OLAP Java API, the MdmSchema class had more than one role. The API had one root MdmSchema, an MdmSchema for each measure folder, and custom MdmSchema objects that an application could create.

The 11g OLAP Java API introduced subclasses of MdmSchema to separate and define the different roles. In 11g, MdmSchema remains a concrete class for compatibility with the earlier versions and for use in 10g metadata reader modes.

In 11g, an MdmSchema is an instance of one of the following subclasses of MdmSchema:

- MdmRootSchema, which is a container for MdmDatabaseSchema objects and is supplied by the system.
- MdmDatabaseSchema, which represents the relational schema for a database user and which creates and owns MdmCube, MdmDimension, and other MdmObject objects. MdmDatabaseSchema objects are supplied by the system.
- MdmOrganizationalSchema, which you can use to organize measures and other MdmOrganizationalSchema objects.

The following topics describe the subclasses of MdmSchema.

- [Representing the Root Schema](#) (page 2-13)
- [Representing Database Schemas](#) (page 2-14)
- [Representing Organizational Schemas](#) (page 2-14)

### 2.3.2.1 Representing the Root Schema

The root schema is a container for database schema objects. This top-level schema is represented by the MdmRootSchema class. You get the MdmRootSchema with the getRootSchema method of the MdmMetadataProvider. From the MdmRootSchema you can get all of the MdmDatabaseSchema objects or you can get an individual MdmDatabaseSchema by name.

The MdmRootSchema class also contains all of the MdmCube, MdmMeasure, and MdmPrimaryDimension objects that are provided by the MdmMetadataProvider, and has methods for getting those objects. However, the List of objects returned by those methods contains only the cubes, measures, or dimensions that the user has permission to see.

Figure 2-4 (page 2-13) shows the associations between an MdmMetadataProvider and the subclasses of MdmSchema.

**Figure 2-4 Associations Between MdmMetadataProvider and the MdmSchema Subclasses**

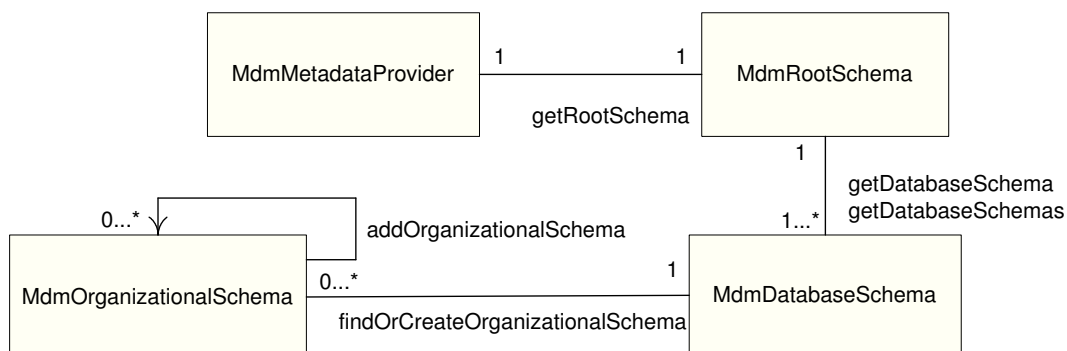

### 2.3.2.2 Representing Database Schemas

The relational schema owned by a database user is represented by an `MdmDatabaseSchema` object.

The `MdmRootSchema` has one `MdmDatabaseSchema` object for each database user. An `MdmDatabaseSchema` has the same name as the database user. For example, the name of the `MdmDatabaseSchema` for the user `GLOBAL` is `GLOBAL`.

You can get one or all of the `MdmDatabaseSchema` objects with methods of the `MdmRootSchema`. However, access to the objects that are owned by an `MdmDatabaseSchema` is determined by the security privileges granted to the user of the session. For information on object and data security management and privileges, see *Oracle OLAP User's Guide*.

An `MdmDatabaseSchema` is the owner of top-level OLAP metadata objects and the objects created by them. You use an `MdmDatabaseSchema` to get existing metadata objects or to create new ones. The top-level objects are the following:

- `AW`
- `MdmCube`
- `MdmNamedBuildProcess`
- `MdmOrganizationalSchema`
- `MdmPrimaryDimension`
- `MdmTable`

Except for an `MdmTable`, you can create new top-level objects, or get existing ones, with the `findOrCreate` methods such as `findOrCreateAW` and `findOrCreateStandardDimension`. Creating objects is described in [Discovering Metadata](#) (page 3-1).

When you commit the `Transaction` in which you have created top-level OLAP metadata objects, those objects then exist in the Oracle data dictionary. They are available for use by ordinary SQL queries as well as for use by applications that use the Oracle OLAP Java API.

Because the metadata objects exist in the Oracle data dictionary, an Oracle Database DBA can restrict access to certain types of the metadata objects. In a client application, you can set such restrictions by using the JDBC API to send standard SQL `GRANT` and `REVOKE` commands through the JDBC connection for the user session.

You can get an `MdmTable`, or other top-level object, with the `getTopLevelObject` method. You can get all of the instances of a particular type of top-level object with methods such as `getAWs`, `getDimensions`, or `getOrganizationalSchemas`, or you can use the `getSchemaObjects` to get all of the objects owned by the `MdmDatabaseSchema`. You can add or remove top-level objects with methods like `addAW` and `removeSchemaObject`.

### 2.3.2.3 Representing Organizational Schemas

An OLAP measure folder organizes measures, cubes, and dimensions. A measure folder is represented by the `MdmOrganizationalSchema` class. Measure folders provide a way to differentiate among the similarly named measures. For example, a user may have access to several schemas with measures named `SALES` or `COSTS`. You could separate measures that have the same name into different

MdmOrganizationalSchema objects. An MdmOrganizationalSchema has methods for adding or removing cubes, dimensions, and measures. You can nest organizational schemas, so the class also has methods for adding and removing other MdmOrganizationalSchema objects.

## 2.4 Providing Access to Data Sources

Some of the classes in the `mdm` package that represent objects that contain or provide access to the data in the data store. Some of these classes represent OLAP dimensional data model objects, which include cubes, measures, dimensions, levels, hierarchies, and attributes. Other `mdm` classes represent relational objects such as tables, or columns in a view or table.

Figure 2-5 (page 2-15) shows the associations between the classes that implement dimensional data model objects. An MdmCube can contain from zero to many MdmMeasure objects. An MdmMeasure is contained by one MdmCube object. An MdmCube can have from zero to many MdmPrimaryDimension objects, which are associated with it through MdmDimensionality objects. An MdmPrimaryDimension can contain from zero to many MdmDimensionLevel objects, MdmHierarchy objects, and MdmAttribute objects.

**Figure 2-5 Associations of Dimensional Data Model Classes**

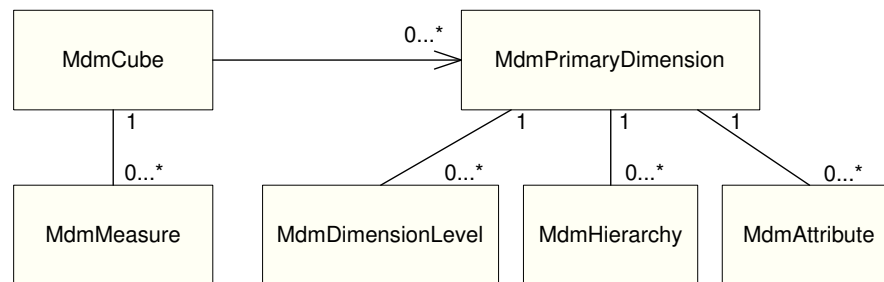

The classes that represent these dimensional or relational data objects are subclasses of the `MdmSource` class. Subclasses of `MdmSource` have a `getSource` method, which returns a `Source` object. You use `Source` objects to define a query of the data. You then use `Cursor` objects to retrieve the data. For more information about working with `Source` and `Cursor` objects, see [Understanding Source Objects](#) (page 5-1) and [Understanding Cursor Classes and Concepts](#) (page 8-1).

You can also use SQL to query the views that Oracle OLAP automatically generates for the cubes, dimensions, and hierarchies. For information on querying these views, see ["Getting Dimension and Hierarchy View and View Column Names"](#) (page 2-30).

The following topics describe the classes that provide access to data sources.

- [Representing Cubes and Measures](#) (page 2-15)
- [Representing Dimensions, Levels, and Hierarchies](#) (page 2-19)
- [Representing Dimension Attributes](#) (page 2-23)
- [Using OLAP Views](#) (page 2-28)

### 2.4.1 Representing Cubes and Measures

Cubes are the physical implementation of the dimensional model. They organize measures that have the same set of dimensions. Cubes and measures are dimensioned

objects; the dimensions associated with a cube identify and categorize the data of the measures. The following topics describe cubes and measures.

- [Representing Cubes](#) (page 2-16)
- [Representing Measures](#) (page 2-17)

#### 2.4.1.1 Representing Cubes

An OLAP cube is represented by the `MdmCube` class. An `MdmCube` is a container for `MdmMeasure` objects that are dimensioned by the same set of `MdmPrimaryDimension` objects. An application creates `MdmBaseMeasure` or `MdmDerivedMeasure` objects with the `findOrCreateBaseMeasure` and `findOrCreateDerivedMeasure` methods of an `MdmCube`. It associates each of the dimensions of the measures with the cube by using the `addDimension` method.

An `MdmCube` usually corresponds to a single fact table or view. To associate the table or view with the cube, you use `Query` and `CubeMap` objects. You get the `Query` for the table or view and then associate the `Query` with the `CubeMap` by using the `setQuery` method of the `CubeMap`.

The `CubeMap` contains `MeasureMap` and `CubeDimensionalityMap` objects that map the measures and dimensions of the cube to data sources. With the `MeasureMap`, you specify an `MdmBaseMeasure` and an `Expression` that identifies the column in the fact table or view that contains the base data for the measure.

To map the dimensions of the cube you get the `MdmDimensionality` objects of the cube. You create a `CubeDimensionalityMap` for each `MdmDimensionality`. You then specify an `Expression` for the `CubeDimensionalityMap` that identifies the foreign key column for the dimension in the fact table or view. If you want to specify a dimension column other than the column for the leaf-level dimension members, then you must specify a join `Condition` with the `setJoinCondition` method of the `CubeDimensionalityMap`.

An `MdmCube` has an associated `CubeOrganization`. The `CubeOrganization` deploys the cube in an analytic workspace or as a relational database object. To deploy a cube to an analytic workspace, you call the `findOrCreateAWCubeOrganization` method of the `MdmCube`. You use the `AWCubeOrganization` returned by that method to specify characteristics of the cube, such as how Oracle OLAP builds the cube, how the cube stores measure data, and whether the database creates materialized views for the cube. For information on the `AWCubeOrganization` class, see *Oracle OLAP Java API Reference*.

If the `AWCubeOrganization` has a materialized view option of `REWRITE_MV_OPTION`, then Oracle OLAP creates a materialized view for the cube that can be used by the database query rewrite system. If the materialized view option is `REWRITE_WITH_ATTRIBUTES_MV_OPTION`, then Oracle OLAP includes in the rewrite materialized view the dimension attributes for which the `isPopulateLineage` method returns `true`. You set the materialized view options with the `setMVOption` method of the `AWCubeOrganization`.

An `MdmCube` also has a `ConsistentSolveSpecification` object, which contains one or more `ConsistentSolveCommand` objects that specify how Oracle OLAP calculates (or *solves*) the values of the measures of the cube. For example, as the `ConsistentSolveCommand`, you could specify an `AggregationCommand` that represents the `SUM` or the `MAX` function. You specify the `ConsistentSolveSpecification` with the `setConsistentSolveSpecification` method of the cube.



A cube is *consistent* when the values of the measures match the specification, for example, when the values of the parents are equal to the SUM of the values of their children. A cube becomes consistent when the `BuildProcess` executes the `ConsistentSolveCommand`.

For examples of creating `MdmCube` and `MdmMeasure` objects and mapping them, and of the other operations described in this topic, see [Example 4-7](#) (page 4-8) and [Example 4-8](#) (page 4-9).

[Figure 2-6](#) (page 2-17) shows the associations between an `MdmCube` and the some of the classes mentioned in this topic. The figure shows an `MdmCube` as deployed in an analytic workspace.

**Figure 2-6 MdmCube and Associated Objects**

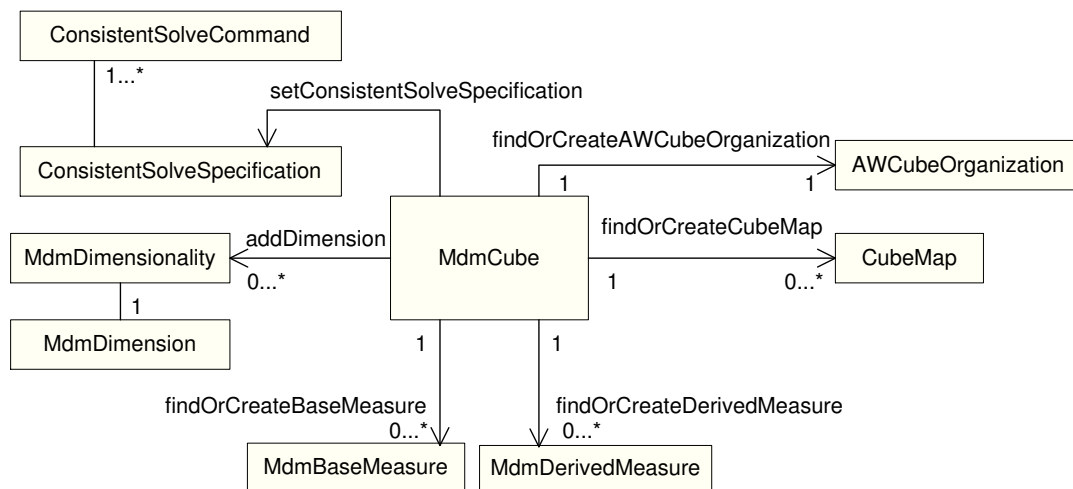

### 2.4.1.2 Representing Measures

An `MdmMeasure` is an abstract class that represents a set of data that is organized by one or more `MdmPrimaryDimension` objects. The structure of the data is similar to that of a multidimensional array. Like the dimensions of an array, which provide the indexes for identifying a specific cell in the array, the `MdmPrimaryDimension` objects that organize an `MdmMeasure` provide the indexes for identifying a specific value of the `MdmMeasure`.

For example, suppose you have an `MdmMeasure` that has data that records the number of product units sold to a customer during a time period and through a sales channel. The data of the measure is organized by dimensions for products, times, customers, and channels (with a channel representing the sales avenue, such as catalog or internet.). You can think of the data as occupying a four-dimensional array with the product, time, customer, and channel dimensions providing the organizational structure. The values of these four dimensions are indexes for identifying each particular cell in the array. Each cell contains a single data value for the number of units sold. You must specify a value for each dimension in order to identify a value in the array.

The values of an `MdmMeasure` are usually numeric, but a measure can have values of other data types. The concrete subclasses of `MdmMeasure` are `MdmBaseMeasure` and `MdmDerivedMeasure`.

An `MdmBaseMeasure` in an analytic workspace has associated physical storage structures. Typically an `MdmCube` gets the base data for an `MdmBaseMeasure` from a

column in a fact table. Oracle OLAP then calculates the aggregate values of the measure and stores those values in an OLAP view for the cube.

When you create an `MdmBaseMeasure`, you can specify the SQL data type of the measure with the `setSQLDataType` method. If you do not specify it, then the `MdmBaseMeasure` has the data type of the source data to which you map it.

By specifying `true` with the `setAllowAutoDataTypeChange` method, you can allow Oracle OLAP to automatically set the SQL data type of the measure. This can be useful if the data type of a measure changes. If you allow the automatic changing of the SQL data type, then Oracle OLAP determines the appropriate SQL data type whether or not you have specified one with the `setSQLDataType` method.

An `MdmDerivedMeasure` has no associated physical storage. Oracle OLAP dynamically calculates the values for an `MdmDerivedMeasure` as needed.

The values of an `MdmMeasure` are determined by the structure of the `MdmPrimaryDimension` objects of the `MdmMeasure`. That is, each value of an `MdmMeasure` is identified by a tuple, which is a unique combination of members from the `MdmPrimaryDimension` objects.

The `MdmPrimaryDimension` objects of an `MdmMeasure` are `MdmStandardDimension` or `MdmTimeDimension` objects. They usually have at least one hierarchical structure. Those `MdmPrimaryDimension` objects include all of the members of their component `MdmHierarchy` objects. Because of this structure, the values of an `MdmMeasure` are of one or more of the following:

- Values from the fact table column, view, or calculation on which the `MdmMeasure` is based. These values are identified by a combination of the members at the leaf levels of the hierarchies of a dimension.
- Aggregated values that Oracle OLAP has provided. These measure values are identified by at least one member from an aggregate level of a hierarchy.
- Values specified by an `Expression` for a `MdmDerivedMeasure` or a custom dimension member.

As an example, imagine an `MdmBaseMeasure` that is dimensioned by an `MdmTimeDimension` and an `MdmStandardDimension` of products. The metadata objects for the measure and the dimensions are `mdmUnitCost`, `mdmTimeDim`, and `mdmProddim`. Each of the `mdmTimeDim` and the `mdmProddim` objects has all of the leaf members and aggregate members of the dimension it represents. A leaf member is one that has no children. An aggregate member has one or more children.

A unique combination of two members, one from `mdmTimeDim` and one from `mdmProddim`, identifies each `mdmUnitCost` value, and every possible combination of dimension members is used to specify the entire set of `mdmUnitCost` values.

Some `mdmUnitCost` values are identified by a combination of leaf members (for example, a particular product item and a particular month). Other `mdmUnitCost` values are identified by a combination of aggregate members (for example, a particular product family and a particular quarter). Still other `mdmUnitCost` values are identified by a mixture of leaf and aggregate members.

The values of `mdmUnitCost` that are identified only by leaf members come directly from the column in the database fact table (or fact table calculation). They represent the lowest level of data. However, the values that are identified by at least one aggregate member are calculated by Oracle OLAP. These higher-level values represent aggregated, or rolled-up, data. Thus, the data represented by an `MdmBaseMeasure` is

a mixture of fact table data from the data store and aggregated data that Oracle OLAP makes available for analytical manipulation.

## 2.4.2 Representing Dimensions, Levels, and Hierarchies

A dimension represents the general concept of a list of members that can organize a set of data. For example, if you have a set of figures that are the prices of product items during month time periods, then the unit price data is represented by an `MdmMeasure` that is dimensioned by dimensions for time and product values. The time dimension includes the month values and the product dimension includes item values. The month and item values act as indexes for identifying each particular value in the set of unit price data.

A dimension can contain levels and hierarchies. Levels can group dimension members into parent and child relationships, where members of lower levels are the children of parents that are in higher levels. Hierarchies define the relationships between the levels. Dimensions usually have associated attributes.

The base class for dimension, level, and hierarchy objects is the abstract class `MdmDimension`, which extends `MdmSource`. An `MdmDimension` has methods for getting and for removing the attributes associated with the object. It also has methods for getting and setting the cardinality and the custom order of the members of the object. The direct subclasses of `MdmDimension` are the abstract `MdmPrimaryDimension` and `MdmSubDimension` classes.

`MdmPrimaryDimension` and `MdmHierarchyLevel` objects can have associated `MdmAttribute` objects. For information on attributes, see "[Representing Dimension Attributes](#) (page 2-23)".

The following topics describe dimensions, levels, and hierarchies.

- [Representing Dimensions](#) (page 2-19)
- [Representing Dimension Levels](#) (page 2-20)
- [Representing Hierarchies](#) (page 2-21)
- [Representing Hierarchy Levels](#) (page 2-23)

### 2.4.2.1 Representing Dimensions

Dimensions are represented by instances of the `MdmPrimaryDimension` class, which is an abstract subclass of `MdmDimension`. The concrete subclasses of the `MdmPrimaryDimension` class represent different types of data. The concrete subclasses of `MdmPrimaryDimension` are the following:

- `MdmMeasureDimension`, which has all of the `MdmMeasure` objects in the data store as the values of the dimension members. A data store has only one `MdmMeasureDimension`. You can obtain the `MdmMeasureDimension` by calling the `getMeasureDimension` method of the `MdmRootSchema`. You can get the measures of the data store by calling the `getMeasures` method of the `MdmMeasureDimension`.
- `MdmStandardDimension`, which has no special characteristics, and which typically represent dimensions of products, customers, distribution channels, and so on.

- `MdmTimeDimension`, which has time periods as the values of the members. Each time period has an end date and a time span. An `MdmTimeDimension` has methods for getting the attributes that record that information.

An `MdmPrimaryDimension` implements the following interfaces.

- `Buildable`, which is a marker interface for objects that you can specify in constructing a `BuildItem`.
- `MdmMemberListMapOwner`, which defines methods for finding or creating, or getting, a `MemberListMap` object.
- `MdmViewColumnOwner`, which is marker interface for objects that can have an associated `MdmViewColumn`.
- `MetadataObject`, which defines a method for getting a unique identifier.
- `MdmQuery`, which defines methods for getting the `Query` object associated with the implementing class and for getting information about the `Query`.

An `MdmPrimaryDimension` can have component `MdmDimensionLevel` objects that organize the dimension members into levels. It also can have `MdmHierarchy` objects, which organize the levels into the hierarchies. An `MdmPrimaryDimension` has all of the members of the component `MdmHierarchy` objects, while each of the `MdmHierarchy` objects has only the members in that hierarchy.

You can get all of the `MdmPrimaryDimension` objects that are contained by an `MdmDatabaseSchema` or an `MdmOrganizationalSchema` by calling the `getDimensions` method of the object. An `MdmDatabaseSchema` has methods for finding an `MdmTimeDimension` or an `MdmStandardDimension` by name or creating the object if it does not already exist.

`MdmStandardDimension` and `MdmTimeDimension` objects contain `MdmAttribute` objects. Some of the attributes are derived by Oracle OLAP, such as the parent attribute, and others you map to data in relational tables or to data that you specify by an `Expression`. For information on attributes, see "[Representing Dimension Attributes](#) (page 2-23)".

An `MdmPrimaryDimension` can organize the dimension members into one or more levels. Each level is represented by an `MdmDimensionLevel` object. An `MdmStandardDimension` or an `MdmTimeDimension` can contain `MdmHierarchy` objects that organize the levels into hierarchical relationships. In an `MdmLevelHierarchy` the dimension levels are represented by `MdmHierarchyLevel` objects. The concrete `MdmDimensionLevel` and `MdmHierarchyLevel` classes, and the abstract `MdmHierarchy` class, are the direct subclasses of the abstract `MdmSubDimension` class.

#### 2.4.2.2 Representing Dimension Levels

An `MdmDimensionLevel` represents a set of dimension members that are at the same level. A dimension member can be in at most one dimension level. You get or create an `MdmDimensionLevel` with the `findOrCreateDimensionLevel` of an `MdmPrimaryDimension`. You can map an `MdmDimensionLevel` to a data source by using a `MemberListMap`.

An `MdmPrimaryDimension` has a method for getting a list of all of the `MdmDimensionLevel` objects that it contains. It also has a method for finding an `MdmDimensionLevel` by name or creating the object if it does not already exist.

### 2.4.2.3 Representing Hierarchies

`MdmHierarchy` is an abstract subclass of `MdmSubDimension`. The concrete subclasses of `MdmHierarchy` are `MdmLevelHierarchy` and `MdmValueHierarchy`.

An `MdmHierarchy` organizes the members of a dimension into a hierarchical structure. The parent-child hierarchical relationships of an `MdmLevelHierarchy` are based on the levels of the dimension. In an `MdmValueHierarchy`, the hierarchical relationships are based on dimension member values and not on levels. An `MdmPrimaryDimension` can have more than one of either or both kinds of hierarchies.

The parent of a hierarchy member is recorded in a parent `MdmAttribute`, which you can get by calling the `getParentAttribute` method of the `MdmHierarchy`. The ancestors of a hierarchy member are recorded in an `ancestors MdmAttribute`, which you can get by calling the `getAncestorsAttribute` method.

An `MdmPrimaryDimension` has a method for getting a list of all of the `MdmHierarchy` objects that it contains. It also has methods for finding an `MdmLevelHierarchy` or `MdmValueHierarchy` by name or creating the object if it does not already exist.

The following topics describe the objects that represent level-based and value-based hierarchies.

- [Representing a Level-based Hierarchy](#) (page 2-21)
- [Representing a Value-based Hierarchy](#) (page 2-22)

#### 2.4.2.3.1 Representing a Level-based Hierarchy

`MdmLevelHierarchy` is a subclass of `MdmHierarchy`. An `MdmLevelHierarchy` has a tree-like structure with a top, or highest, level, and a leaf, or lowest, level. Each member may have zero or one parent in the hierarchy. Cycles are not allowed, for example where member A is the parent of member B, member B is the parent of member C, and member C is the parent of member A.

Members that are not the child of any other member are the *top* members. Members with children are *aggregates* or *aggregate members* of the hierarchy. Members with no children are the *leaves* or *leaf members* of the hierarchy.

Each member is in a level. The levels are ordered, from top level to leaf level. The order is determined by the order in which you create the `MdmDimensionLevel` objects of the `MdmPrimaryDimension`. The first `MdmDimensionLevel` that you create is the top level and the last one you create is the leaf level. For example, for the `CALENDAR_YEAR` hierarchy of the `TIME_AWJ` dimension, the `CreateAndBuildAW.java` and `SpecifyAWValues` example programs create four `MdmDimensionLevel` objects in the following order: `TOTAL_TIME`, `YEAR`, `QUARTER`, and `MONTH`. The top level is `TOTAL_TIME` and the leaf level is `MONTH`.

If a member of the hierarchy has a parent, then that parent must be in a higher level. Oracle OLAP expects that all leaf members in the hierarchy are in the leaf level. You can specify that Oracle OLAP allow the hierarchy to be *ragged*. In a ragged hierarchy, one or more leaf members are not in the leaf level. You can specify allowing the hierarchy to be ragged by calling the `setIsRagged(true)` method of the `MdmLevelHierarchy`.

Oracle OLAP also expects that if a member is in a level below the top level, then that member has a parent, and that the parent is in the level just above the level of the

member. If a member is not at the top level and that member either does not have a parent or the parent is not in the next higher level, then the hierarchy is a skip-level hierarchy. You can specify allowing a skip-level hierarchy by calling the `setIsSkipLevel(true)` method of the `MdmLevelHierarchy`.

Figure 2-7 (page 2-22) illustrates the relationships of members in a regular hierarchy, a ragged hierarchy, and two types of skip-level hierarchies.

**Figure 2-7 Regular, Ragged, and Skip-level Hierarchies**

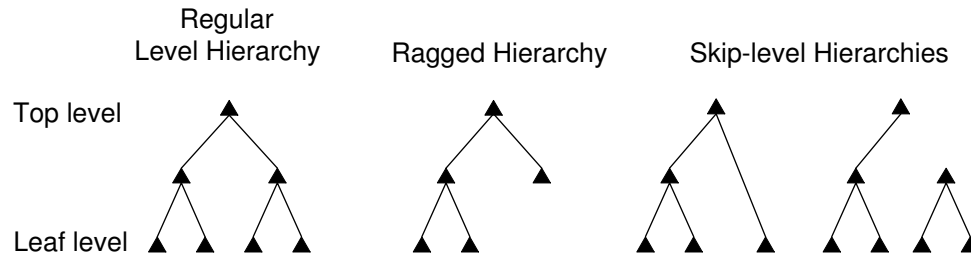

The different levels of an `MdmLevelHierarchy` are represented by `MdmHierarchyLevel` objects. For an example of creating a level-based hierarchy, see "Creating and Mapping an `MdmLevelHierarchy` (page 4-4)".

The `MdmLevelHierarchy` has all of the members of the hierarchy, and each of the component `MdmHierarchyLevel` objects has only the members at the level that it represents. An `MdmLevelHierarchy` can also represent a nonhierarchical list of members, in which case the `MdmLevelHierarchy` has one `MdmHierarchyLevel`, and both objects have the same members. You get the levels of an `MdmLevelHierarchy` by calling the `getHierarchyLevels` method.

An `MdmLevelHierarchy` has a method for getting a list of all of the `MdmHierarchyLevel` objects that it contains. It also has a method for finding an `MdmHierarchyLevel` by name or creating the object if it does not already exist.

An `MdmPrimaryDimension` can contain more than one `MdmLevelHierarchy`. For example, an `MdmTimeDimension` dimension might have two `MdmLevelHierarchy` objects, one organized by calendar year time periods and the other organized by fiscal year time periods. The `MdmHierarchyLevel` objects of one hierarchy associate `MdmDimensionLevel` objects of calendar year time periods with the hierarchy. The `MdmHierarchyLevel` objects of the other hierarchy associate `MdmDimensionLevel` objects of fiscal year time periods with that hierarchy. Generally, level-based hierarchies share the lowest level, so the `MdmHierarchyLevel` for the lowest level of each of the hierarchies associates the same `MdmDimensionLevel` with each hierarchy. For example, the calendar year hierarchy and the fiscal year hierarchy share the same `MdmHierarchyLevel` of month time periods.

#### 2.4.2.3.2 Representing a Value-based Hierarchy

A value-based hierarchy is one in which levels are not meaningful in defining the hierarchical relationships. This type of hierarchy is represented by the `MdmValueHierarchy` class, which is a subclass of `MdmHierarchy`. An example of a value hierarchy is the employee reporting structure of a company, which can be represented with parent-child relationships but without levels. For an example of creating a value-based hierarchy, see "Creating and Mapping an `MdmValueHierarchy` (page 4-5)".

The OLAP view for the value hierarchy has a column that contains all employees, including those who are managers. It has another column that contains the parent members. Another column identifies the depth of the member in the hierarchy, where

the member that has no manager is at depth 0 (zero), the employees who report to that manager are at level 1, and so on.

#### 2.4.2.4 Representing Hierarchy Levels

`MdmHierarchyLevel` is a subclass of `MdmSubDimension`. An `MdmHierarchyLevel` associates an `MdmDimensionLevel` with an `MdmLevelHierarchy`.

The order of the levels in the hierarchy is specified by the order in which you create the `MdmHierarchyLevel` objects for the `MdmLevelHierarchy`. The first `MdmHierarchyLevel` that you create is the highest level and the last one that you create is the lowest level. For an example of creating a hierarchy, see "[Creating and Mapping an MdmLevelHierarchy](#) (page 4-4)".

### 2.4.3 Representing Dimension Attributes

An OLAP dimension attribute is represented by an `MdmAttribute` object. An `MdmAttribute` has values that are related to members of an `MdmPrimaryDimension`. The `MdmAttribute` class is a subclass of `MdmDimensionedObject` because, like an `MdmMeasure`, the values of an `MdmAttribute` have meaning in relation to the members of the dimension.

The relation can be one-to-one, many-to-one, or one-to-many. For example, the `PRODUCT_AWJ` dimension has a short description attribute, a package attribute, and an ancestors attribute. The short description attribute has a separate value for each dimension member. The package attribute has a set of values, each of which applies to more than one dimension member. The ancestors attribute has multiple values that apply to a single dimension member. If an `MdmAttribute` does not apply to a member of an `MdmDimension`, then the `MdmAttribute` value for that member is `null`.

[Table 2-3](#) (page 2-23) shows the first few members of the `PRODUCT_AWJ` dimension and their related short description and package attribute values. Only some of the members of the `ITEM` level of the dimension have a package attribute. For other items, and for higher levels, the package attribute value is `null`, which appears as `NA` in the table.

**Table 2-3** *Dimension Members and Related Attribute Values*

Dimension Member	Related Short Description	Related Package
<code>TOTAL_PRODUCT::TOTAL</code>	Total Product	NA
<code>CLASS::HRD</code>	Hardware	NA
<code>FAMILY::DISK</code>	CD/DVD	NA
<code>ITEM::EXT CD ROM</code>	External 48X CD-ROM	NA
<code>ITEM::EXT DVD</code>	External - DVD-RW - 8X	Executive
<code>ITEM::INT 8X DVD</code>	Internal - DVD-RW - 8X	NA
<code>ITEM::INT CD ROM</code>	Internal 48X CD-ROM	Laptop Value Pack
<code>ITEM::INT CD USB</code>	Internal 48X CD-ROM USB	NA
<code>ITEM::INT RW DVD</code>	Internal - DVD-RW - 6X	Multimedia

**Table 2-3 (Cont.) Dimension Members and Related Attribute Values**

Dimension Member	Related Short Description	Related Package
...	...	...

To get values from an `MdmAttribute`, you must join the `Source` for the `MdmAttribute` and a `Source` that specifies one or more members of the `MdmDimension`. For an explanation of joining `Source` objects, see [Understanding Source Objects](#) (page 5-1). For examples of joining the `Source` objects for an `MdmAttribute` and an `MdmDimension`, see [Example 4-5](#) (page 4-5) and examples from [Understanding Source Objects](#) (page 5-1) and [Making Queries Using Source Methods](#) (page 6-1), such as [Example 5-7](#) (page 5-14) and [Example 6-10](#) (page 6-18).

The following topics describe the classes that represent dimension attributes.

- [Describing the MdmAttribute Class](#) (page 2-24)
- [Describing the MdmBaseAttribute Class](#) (page 2-25)
- [Describing the MdmDerivedAttribute Class](#) (page 2-28)

### 2.4.3.1 Describing the MdmAttribute Class

The abstract `MdmAttribute` class has a subclass, which is the abstract class `MdmSingleValuedAttribute`. That class has two concrete subclasses: `MdmBaseAttribute` and `MdmDerivedAttribute`.

#### 2.4.3.1.1 Describing Types of Attributes

An `MdmAttribute` is contained by the `MdmPrimaryDimension` that creates it. Some attributes, such as the parent attribute and the level attribute, are derived by Oracle OLAP from the structure of the dimension. Others are common attributes for which an `MdmPrimaryDimension` has accessor methods, such as the long and short description attributes, or the end date and time span attributes that an `MdmTimeDimension` requires. After you create one of those attributes, you associate it with the dimension through a method such as the `setShortValueDescriptionAttribute` method of an `MdmPrimaryDimension` or the `setTimeSpanAttribute` method of an `MdmTimeDimension`. You can also create attributes for your own purposes, such as the `PACKAGE` attribute in the `GLOBAL_AWJ` example analytic workspace.

#### 2.4.3.1.2 Associating an Attribute with an MdmSubDimension

After you create an attribute, you associate it with an `MdmSubDimension`. You can associate it with just a single `MdmSubDimension` by using the `addAttribute` method of the `MdmSubDimension`. You can also associate it with all of the `MdmDimensionLevel` objects of an `MdmPrimaryDimension` by using the `setIsVisibleForAll` method of the `MdmAttribute`. If you specify `true` with the `setIsVisibleForAll` method, then the attribute applies to all of the `MdmDimensionLevel` objects that are currently contained by the `MdmPrimaryDimension` and to any `MdmDimensionLevel` objects that you subsequently create or add to the dimension.



### 2.4.3.1.3 Getting MdmAttribute Objects

The `getAttributes` method of an `MdmPrimaryDimension` returns all of the `MdmAttribute` objects that were created by a client application. The `getAttributes` method of an `MdmSubDimension` returns only those attributes that the application added to it with the `addAttribute` method. Other methods of an `MdmPrimaryDimension` return specific attributes that Oracle OLAP generates, such as the `getHierarchyAttribute`, the `getLevelDepthAttribute`, or the `getParentAttribute` method.

### 2.4.3.1.4 Specifying a Target Dimension

A target dimension for an attribute is similar to defining a foreign key constraint between columns in a table. All of the values of the attribute must also be keys of the target dimension.

You can specify a target dimension for an attribute by using the `setTargetDimension` method of the `MdmAttribute`. The relational table that is the Query for the target dimension must have a column that contains all of the values that are in the column of the dimension table to which you map the attribute.

### 2.4.3.2 Describing the MdmBaseAttribute Class

An `MdmBaseAttribute` has values that are stored in the OLAP views for the dimension that contains it and the hierarchy to which it applies. For information on OLAP views, see "[Using OLAP Views](#) (page 2-28)".

You create an `MdmBaseAttribute` with the `findOrCreateBaseAttribute` method of an `MdmPrimaryDimension`. You map the `MdmBaseAttribute` to a column in a relational table or view. When you build the `MdmPrimaryDimension` that created the attribute, Oracle OLAP stores the values of the `MdmBaseAttribute` in an OLAP view. You can get the column for the `MdmBaseAttribute` in the OLAP view by using the `getETAttributeColumn` method. That method returns an `MdmViewColumn` object.

Examples of `MdmBaseAttribute` objects are the name attribute created and mapped in [Example 4-5](#) (page 4-5) and the long description attribute created in [Example 4-6](#) (page 4-7). The mapping for that long description attribute is in [Example 4-3](#) (page 4-3).

For regular OLAP queries, using Source objects, you only need to map an `MdmBaseAttribute` to `MdmDimensionLevel` objects by using `MemberListMap` objects. For SQL queries against OLAP views, you should map the attributes to `MdmHierarchyLevel` objects by using `HierarchyLevelMap` objects.

#### 2.4.3.2.1 Specifying a Data Type

When you create an `MdmBaseAttribute`, you can specify the SQL data type with the `setSQLDataType` method. If you do not specify it, then the `MdmBaseAttribute` has the data type of the source data to which you map it. For example, the SQL data type of the short description attribute is `VARCHAR2` and the data type of the end date attribute is `DATE`.

By specifying `true` with the `setAllowAutoDataTypeChange` method, you can allow Oracle OLAP to automatically set the SQL data type. If you allow the automatic changing of the SQL data type, then Oracle OLAP ignores the SQL data type specified by the `setSQLDataType` method. This can be useful if you map the same attribute to levels that have different data types, or if the data type of a level changes.

#### 2.4.3.2.2 Grouping Attributes

With the `setAttributeGroupName` method of an `MdmBaseAttribute`, you can specify a name for an attribute group. You can specify the same group name for other attributes. For example, you could create a long description attribute for each dimension level and give each attribute the group name of `LONG_DESCRIPTION`. You could use the group name to identify similar kinds of attributes. You get the group name with the `getAttributeGroupName` method.

#### 2.4.3.2.3 Creating an Index

You can improve the performance of attribute-based queries by creating an index for the attribute. Creating an index adds maintenance time and increases the size of the analytic workspace, which may increase the build time for extremely large dimensions. You create an index for an attribute by specifying `true` with the `setCreateAttributeIndex` method of the `AWAttributeOrganization` for the `MdmBaseAttribute`.

#### 2.4.3.2.4 Specifying a Language for an Attribute

When you create an `AttributeMap` for an `MdmBaseAttribute`, you can specify a language for the attribute. For example, to specify French as the language for the long description attribute for the `MdmDimensionLevel` named `CHANNEL`, you would create an `AttributeMap` by calling the `MemberListMap.findOrCreateAttributeMap` method and passing in the long description `MdmBaseAttribute` and `FRENCH` as the `String` that specifies the language. You would then specify `GLOBAL.CHANNEL_DIM.CHANNEL_DSC_FRENCH` as the `Expression` for the `AttributeMap`. By using the `setLanguage` method of an `AttributeMap`, you can specify a language for an `AttributeMap` after you have created it.

#### 2.4.3.2.5 Specifying Multilingual Attributes

The `MdmBaseAttribute.setMultiLingual` method allows you to map more than one language column to the same attribute. To do so, you specify `true` with the `setMultiLingual` method of the attribute. You then create a separate `AttributeMap` for each language but you use the same `MdmBaseAttribute`.

The language in use for the database determines which language appears in the OLAP view for the dimension. Only one language is in use at a time in a session, but if the language in use changes, then the language in the attribute column in the OLAP view also changes. For more information on specifying languages for database sessions, see *Setting Up a Globalization Support Environment* in *Oracle Database Globalization Support Guide*.

For materialized views, you should create a separate attribute for each language, so that there is a long description attribute for English, one for French, and so on. That behavior is more typical in SQL, which does not expect multivalued columns.

#### 2.4.3.2.6 Populating OLAP Views with Hierarchical Attribute Values

For SQL queries, you should populate the lineage of the attributes in the view by specifying `true` with the `MdmBaseAttribute.setPopulateLineage` method. Populating the lineage means that in the column for an attribute in an OLAP view, Oracle OLAP populates the rows for lower levels in a dimension hierarchy with the attribute values that are mapped at a higher level. Populating the lineage for the attributes is also useful if you are creating materialized views for an analytic workspace cube.

If you specify `setPopulateLineage(false)`, which is the default for the setting, then the attribute values appear only in the rows for the hierarchy members at the level to which the attribute is mapped. For hierarchy members at other levels, the attribute value is null. If you specify `setPopulateLineage(true)`, then the attribute values appear in the rows for the members of the mapped level and for the hierarchy members of all levels that are descendants of the mapped level.

Populating the hierarchy lineage in an OLAP view makes the contents of the view more like the contents of a relational table in a star schema. For example, you could create a separate long description attribute on the dimension for each `MdmDimensionLevel` of the dimension. You would specify populating the lineage of those attributes by calling the `setPopulateLineage(true)` method of each attribute. You would then make the attribute visible for a hierarchy level by adding the attribute to the `MdmHierarchyLevel` with the `addAttribute` method.

The OLAP view for a hierarchy of the dimension would then have a column for each of the long description attributes. Those columns would contain the long description attribute values for the members of the mapped hierarchy level and for the hierarchy members of all levels that are descendants of the mapped level.

For example, the `CreateAndBuildAW` example class has a line of code that specifies populating the lineage for the `MdmBaseAttribute` objects that it adds to each individual `MdmHierarchyLevel`. The following line appears in the `createLineageAttributes` method of the class.

```
mdmAttr.setPopulateLineage(true);
```

[Example 2-2](#) (page 2-27) shows the results of the following SQL query when that line of code is commented out. [Example 2-3](#) (page 2-28) shows the results of the SQL query when the line is included in the class. Both examples show the values that are in the selected columns of the OLAP view for the `PRODUCT_PRIMARY` hierarchy. The view name is `PRODUCT_AWJ_PRODUCT_PRIMA_VIEW`. The examples show only a few of the lines returned by the SQL query.

```
SELECT TOTAL_PRODUCT_SHORT_DESC || '*' || CLASS_SHORT_DESC || '*' ||
       FAMILY_SHORT_DESC || '*' || ITEM_SHORT_DESC
FROM PRODUCT_AWJ_PRODUCT_PRIMA_VIEW
ORDER BY TOTAL_PRODUCT nulls first, CLASS nulls first,
       FAMILY nulls first, ITEM nulls first;
```

### **Example 2-2 Values in OLAP View Columns After `setPopulateLineage(false)`**

In this example, the attribute rows of the OLAP view have only the attribute values for the hierarchy level to which the dimension member belongs.

```
TOTAL_PRODUCT_SHORT_DESC || '*' || CLASS_SHORT_DESC || '*' || FAMILY_SHORT_DESC || '*' || IT
-----
Total Product***
*Hardware**
**CD/DVD*
***External 48X CD-ROM
***External - DVD-RW - 8X
***Internal - DVD-RW - 8X
...
**Desktop PCs*
***Sentinel Financial
***Sentinel Multimedia
***Sentinel Standard
**Portable PCs*
***Envoy Ambassador
***Envoy Executive
```

```
***Envoy Standard
...
```

**Example 2-3 Values in OLAP View Columns After setPopulateLineage(true)**

In this example , the attribute rows of the OLAP view are populated with the attribute values for the ancestors of a dimension member. For example, the first row contains only the value Total Product because TOTAL\_PRODUCT is the highest level in the hierarchy. The row that contains the value Envoy Standard also has the values for the TOTAL\_PRODUCT, CLASS, and FAMILY levels.

```
TOTAL_PRODUCT_SHORT_DESC|| '*' || CLASS_SHORT_DESC|| '*' || FAMILY_SHORT_DESC|| '*' || IT
-----
Total Product***
Total Product*Hardware**
Total Product*Hardware*CD/DVD*
Total Product*Hardware*CD/DVD*External 48X CD-ROM
Total Product*Hardware*CD/DVD*External - DVD-RW - 8X
Total Product*Hardware*CD/DVD*Internal - DVD-RW - 8X
...
Total Product*Hardware*Desktop PCs*
Total Product*Hardware*Desktop PCs*Sentinel Financial
Total Product*Hardware*Desktop PCs*Sentinel Multimedia
Total Product*Hardware*Desktop PCs*Sentinel Standard
Total Product*Hardware*Portable PCs*
Total Product*Hardware*Portable PCs*Envoy Ambassador
Total Product*Hardware*Portable PCs*Envoy Executive
Total Product*Hardware*Portable PCs*Envoy Standard
...
```

**2.4.3.2.7 Preparing Attributes for Materialized Views**

To generate materialized views for the OLAP metadata objects, for each MdmDimensionLevel you must create an MdmBaseAttribute, map it to a unique key for the MdmDimensionLevel, and add it to the MdmDimensionLevel. An MdmDimensionLevel has methods for adding, getting, and removing unique key attributes. The EnableMVs.java example program creates unique key attributes and adds them to the MdmDimensionLevel objects of the dimensions. For information about using materialized views, see *Oracle OLAP User's Guide*.

When Oracle OLAP creates a materialized view for a cube, it creates columns for the attributes of the dimensions of the cube. For the name of a column, it uses the name of the attribute column from the OLAP view of the dimension. To ensure that the column name is unique, Oracle OLAP adds a default prefix to the name. You can specify the prefix by using the setETAttrPrefix method of the MdmDimensionality object for a dimension of the cube.

**2.4.3.3 Describing the MdmDerivedAttribute Class**

An MdmDerivedAttribute has values that Oracle OLAP calculates on the fly as you need them. Oracle OLAP generates several MdmDerivedAttribute objects, such as the attributes returned by the getParentAttribute and the getAncestorsAttribute methods of an MdmPrimaryDimension.

**2.4.4 Using OLAP Views**

For each instance of an MdmCube, MdmPrimaryDimension, and MdmHierarchy in an analytic workspace, Oracle OLAP automatically creates an associated relational view. Oracle OLAP uses these views internally to provide access to the aggregate and calculated data that is generated by the analytic workspace. An OLAP Java API query

transparently uses the views. In the OLAP Java API, these views are called ET (embedded totals) views.

A SQL application can directly query these views, using them as it would the fact tables and dimension tables of a star or snowflake schema. The *Oracle OLAP User's Guide* documentation refers to these views as OLAP views and describes them in detail. For those detailed descriptions, see *Oracle OLAP User's Guide*.

A client OLAP Java API application can get the names of the OLAP views and get the names of columns in the views. The application could display the names to the end user of the application, and the end user could then use the names in a SQL SELECT statement to query the OLAP objects.

The following topics describe getting and using these views.

- [Getting Cube View and View Column Names](#) (page 2-29)
- [Getting Dimension and Hierarchy View and View Column Names](#) (page 2-30)
- [Using OLAP View Columns](#) (page 2-31)
- [Using Source Objects](#) (page 2-34)

#### 2.4.4.1 Getting Cube View and View Column Names

To get the name of a cube view, call the `MdmCube.getViewName()` method. For example, the following code gets the name of the view for the `MdmCube` that is named `UNITS_CUBE_AWJ`. In the code, the `mdmDBSchema` object is the `MdmDatabaseSchema` for the `GLOBAL` user.

```
MdmCube mdmUnitsCube =
    (MdmCube)mdmDBSchema.getTopLevelObject("UNITS_CUBE_AWJ");
String cubeViewName = mdmUnitsCube.getViewName();
println("The name of the view for the " +
    mdmUnitsCube.getName() + " cube is " + cubeViewName + ".");
```

The output of the code is the following.

```
The name of the view for the UNITS_CUBE_AWJ cube is UNITS_CUBE_AWJ_VIEW.
```

You can change the name of the OLAP view by using the `MdmCube.setViewName` method. To make the name change permanent, you must commit the `Transaction`.

The OLAP view for an `MdmCube` has a column for each measure of the cube, including each derived measure. In *Oracle OLAP User's Guide*, a derived measure is known as a calculated measure. A cube view also has a column for each dimension of the cube. For example, for the `MdmCube` named `UNITS_CUBE_AWJ`, the view is named `UNITS_CUBE_AWJ_VIEW`. The following code gets the names of the view columns.

```
MdmCube mdmUnitsCube = mdmDBSchema.findOrCreateCube("UNITS_CUBE_AWJ");
List<MdmQueryColumn> mdmQCols = mdmUnitsCube.getQueryColumns();
for (MdmQueryColumn mdmQCol : mdmQCols )
{
    MdmViewColumn mdmViewCol = (MdmViewColumn) mdmQCol;
    println(mdmViewCol.getViewColumnName());
}
```

The code displays the following output.

```
TIME_AWJ
PRODUCT_AWJ
CUSTOMER_AWJ
```

```
CHANNEL_AWJ
UNITS
SALES
COST
```

The UNITS, SALES, and COST columns are for the measures of the cube, and the other four columns are for the dimensions of the cube.

#### 2.4.4.2 Getting Dimension and Hierarchy View and View Column Names

To get the name of the OLAP view for a dimension or a hierarchy, call the `getETViewName()` method of the `MdmPrimaryDimension` or `MdmHierarchy`. You can get the name of a column in the view by calling the appropriate method of the metadata object. For example, the following code gets the name of the key column for the CHANNEL\_AWJ dimension and the parent column for the CHANNEL\_PRIMARY hierarchy.

```
println(mdmChanDim.getETKeyColumn().getViewColumnName());
MdmViewColumn mdmParentCol =(MdmViewColumn) mdmChanHier.getETParentColumn();
println(mdmParentCol.getViewColumnName());
```

The code displays the following output.

```
DIM_KEY
PARENT
```

You can change the name of the OLAP view by using the `setETViewName` method of the `MdmPrimaryDimension` or `MdmHierarchy`.

The OLAP view for an `MdmPrimaryDimension` has a column for the dimension keys, a column for each dimension level, and a column for each attribute associated with the dimension. For example, for the `MdmStandardDimension` named CHANNEL\_AWJ, the view is named CHANNEL\_AWJ\_VIEW. The SQL command `DESCRIBE CHANNEL_AWJ_VIEW` displays the names of the following columns.

```
DIM_KEY
LEVEL_NAME
MEMBER_TYPE
DIM_ORDER
LONG_DESCRIPTION
SHORT_DESCRIPTION
TOTAL_CHANNEL_LONG_DESC
TOTAL_CHANNEL_SHORT_DESC
CHANNEL_LONG_DESC
CHANNEL_SHORT_DESC
```

The OLAP view for an `MdmHierarchy` has a column for the dimension keys and a column for the parent of a hierarchy member. If it is an `MdmLevelHierarchy`, then it also has a column for each hierarchy level and a column for the depth of a level. If the hierarchy has one or more added attributes, then the view has a column for each attribute. For example, for the `MdmLevelHierarchy` named CHANNEL\_PRIMARY, the view is named CHANNEL\_AWJ\_CHANNEL\_PRIMA\_VIEW. The SQL command `DESCRIBE CHANNEL_AWJ_CHANNEL_PRIMA_VIEW` displays the names of the following columns.

```
DIM_KEY
LEVEL_NAME
MEMBER_TYPE
DIM_ORDER
HIER_ORDER
LONG_DESCRIPTION
```

```

SHORT_DESCRIPTION
TOTAL_CHANNEL_LONG_DESC
TOTAL_CHANNEL_SHORT_DESC
CHANNEL_LONG_DESC
CHANNEL_SHORT_DESC
PARENT
DEPTH
TOTAL_CHANNEL
CHANNEL

```

### 2.4.4.3 Using OLAP View Columns

See *Oracle OLAP User's Guide* for several examples of how to create SQL queries using the OLAP views. An OLAP Java API query that uses `Source` objects automatically uses these views.

You can also provide direct access to the OLAP views to the users of your OLAP Java API application. You could allow users to specify a SQL `SELECT` statement that uses the views and then send that SQL query to the database.

[Example 2-4](#) (page 2-31) reproduces [Example 4-2](#) of *Oracle OLAP User's Guide* except that it uses the cubes and dimensions of the analytic workspace. The example selects the SALES measure from `UNITS_CUBE_AWJ_VIEW`, and joins the keys from the cube view to the hierarchy views to select the data.

In the example, `mdmDBSchema` is the `MdmDatabaseSchema` for the GLOBAL user. The example is an excerpt from the `BasicCubeViewQuery.java` example program.

#### Example 2-4 Basic Cube View Query

```

// In a method...
// Get the cube.
MdmCube mdmUnitsCube =
    (MdmCube)mdmDBSchema.getTopLevelObject("UNITS_CUBE_AWJ");
// Get the OLAP view for the cube.
String cubeViewName = mdmUnitsCube.getViewName();
// Display the name of the OLAP view for the cube.
println("The name of the OLAP view for the " + mdmUnitsCube.getName()
    + " cube is:\n " + cubeViewName);

// Get the dimensions and the hierarchies of the dimensions.
MdmPrimaryDimension mdmTimeDim =
    (MdmPrimaryDimension)mdmDBSchema.getTopLevelObject("TIME_AWJ");
MdmLevelHierarchy mdmCalHier =
    mdmTimeDim.findOrCreateLevelHierarchy("CALENDAR_YEAR");

// Display the name of the OLAP view name for the hierarchy and
// display the names of the hierarchy levels.
displayViewAndLevelNames(mdmCalHier);

MdmPrimaryDimension mdmProdDim =
    (MdmPrimaryDimension)mdmDBSchema.getTopLevelObject("PRODUCT_AWJ");
MdmLevelHierarchy mdmProdHier =
    mdmProdDim.findOrCreateLevelHierarchy("PRODUCT_PRIMARY");
displayViewAndLevelNames(mdmProdHier);

MdmPrimaryDimension mdmCustDim =
    (MdmPrimaryDimension)mdmDBSchema.getTopLevelObject("CUSTOMER_AWJ");
MdmLevelHierarchy mdmShipHier =
    mdmCustDim.findOrCreateLevelHierarchy("SHIPMENTS");
displayViewAndLevelNames(mdmShipHier);

```

```

MdmPrimaryDimension mdmChanDim =
    (MdmPrimaryDimension)mdmDBSchema.getTopLevelObject("CHANNEL_AWJ");
MdmLevelHierarchy mdmChanHier =
    mdmChanDim.findOrCreateLevelHierarchy("CHANNEL_PRIMARY");
displayViewAndLevelNames(mdmChanHier);

// Create a SQL SELECT statement using the names of the views and the
// levels.
// UNITS_CUBE_AWJ_VIEW has a column named SALES for the sales measure.
// TIME_AWJ_CALENDAR_YEAR_VIEW has a column named LONG_DESCRIPTION
// for the long description attribute.
// The hierarchy views have columns that have the same names as the levels.
String sql = "SELECT t.long_description time,\n" +
    "    ROUND(f.sales) sales\n" +
    " FROM TIME_AWJ_CALENDAR_YEAR_VIEW t,\n" +
    "    PRODUCT_AWJ_PRODUCT_PRIMA_VIEW p,\n" +
    "    CUSTOMER_AWJ_SHIPMENTS_VIEW cu,\n" +
    "    CHANNEL_AWJ_CHANNEL_PRIMA_VIEW ch,\n" +
    "    UNITS_CUBE_AWJ_VIEW f\n" +
    " WHERE t.level_name = 'YEAR'\n" +
    "    AND p.level_name = 'TOTAL_PRODUCT'\n" +
    "    AND cu.level_name = 'TOTAL_CUSTOMER'\n" +
    "    AND ch.level_name = 'TOTAL_CHANNEL'\n" +
    "    AND t.dim_key = f.time_awj\n" +
    "    AND p.dim_key = f.product_awj\n" +
    "    AND cu.dim_key = f.customer_awj\n" +
    "    AND ch.dim_key = f.channel_awj\n" +
    " ORDER BY t.end_date";

// Display the SQL SELECT statement.
println("\nThe SQL SELECT statement is:\n" + sql);

// Display the results of the SQL query.
String title = "\nThe results of the SQL query are:\n";
executesSQL(sql, title);
// ...
} // End of method.

private void displayViewAndLevelNames(MdmLevelHierarchy mdmLevelHier)
{
    // Get the OLAP view name for the hierarchy.
    String levelHierViewName = mdmLevelHier.getETViewName();
    // Display the name of the OLAP view for the hierarchy.
    println("\nThe OLAP view for the " + mdmLevelHier.getName() +
        " hierarchy is:\n " + levelHierViewName);

    // Display the names of the levels of the hierarchy.
    displayLevelNames(mdmLevelHier);
}

private void displayLevelNames(MdmLevelHierarchy mdmLevelHier)
{
    List<MdmHierarchyLevel> mdmHierLevelList =
        mdmLevelHier.getHierarchyLevels();
    println("The names of the levels of the "
        + mdmLevelHier.getName() + " hierarchy are:");
    for (MdmHierarchyLevel mdmHierLevel : mdmHierLevelList)
    {
        println(" " + mdmHierLevel.getName());
    }
}

```



```
// The executeSQL method is in the BaseExample11g class.
protected void executeSQL(String sql, String heading)
{
    try
    {
        Statement statement = dp.getConnection().createStatement();
        println(heading);
        ResultSet rs = statement.executeQuery(sql);
        SQLResultSetPrinter.printResultSet(getCursorPrintWriter(), rs);
        rs.close();
        statement.close();
    }
    catch (SQLException e)
    {
        println("Could not execute SQL statement. " + e);
    }
}
}
```

The output of the example is the following.

The name of the OLAP view for the UNITS\_CUBE\_AWJ cube is:  
UNITS\_CUBE\_AWJ\_VIEW

The OLAP view for the CALENDAR\_YEAR hierarchy is:  
TIME\_AWJ\_CALENDAR\_YEAR\_VIEW

The names of the levels of the CALENDAR\_YEAR hierarchy are:  
TOTAL\_TIME  
YEAR  
QUARTER  
MONTH

The OLAP view for the PRODUCT\_PRIMARY hierarchy is:  
PRODUCT\_AWJ\_PRODUCT\_PRIMA\_VIEW

The names of the levels of the PRODUCT\_PRIMARY hierarchy are:  
TOTAL\_PRODUCT  
CLASS  
FAMILY  
ITEM

The OLAP view for the SHIPMENTS hierarchy is:  
CUSTOMER\_AWJ\_SHIPMENTS\_VIEW

The names of the levels of the SHIPMENTS hierarchy are:  
TOTAL\_CUSTOMER  
REGION  
WAREHOUSE  
SHIP\_TO

The OLAP view for the CHANNEL\_PRIMARY hierarchy is:  
CHANNEL\_AWJ\_CHANNEL\_PRIMA\_VIEW

The names of the levels of the CHANNEL\_PRIMARY hierarchy are:  
TOTAL\_CHANNEL  
CHANNEL

The SQL SELECT statement is:  
SELECT t.long\_description time,  
 ROUND(f.sales) sales  
FROM TIME\_AWJ\_CALENDAR\_YEAR\_VIEW t,  
 PRODUCT\_AWJ\_PRODUCT\_PRIMA\_VIEW p,  
 CUSTOMER\_AWJ\_SHIPMENTS\_VIEW cu,  
 CHANNEL\_AWJ\_CHANNEL\_PRIMA\_VIEW ch,

```

        UNITS_CUBE_AWJ_VIEW f
    WHERE t.level_name = 'YEAR'
        AND p.level_name = 'TOTAL_PRODUCT'
        AND cu.level_name = 'TOTAL_CUSTOMER'
        AND ch.level_name = 'TOTAL_CHANNEL'
        AND t.dim_key = f.time_awj
        AND p.dim_key = f.product_awj
        AND cu.dim_key = f.customer_awj
        AND ch.dim_key = f.channel_awj
    ORDER BY t.end_date

```

The results of the SQL query are:

TIME	SALES
1998	100870877
1999	134109248
2000	124173522
2001	116931722
2002	92515295
2003	130276514
2004	144290686
2005	136986572
2006	140138317
2007	<null>

#### 2.4.4.4 Using Source Objects

[Example 2-4](#) (page 2-31) demonstrates how to create a SQL statement using the OLAP views. You can produce the same results by using OLAP Java API Source objects, as shown in [Example 2-5](#) (page 2-34). The code in [Example 2-5](#) (page 2-34) uses the `MdmLevelHierarchy` objects from [Example 2-4](#) (page 2-31).

##### **Example 2-5 Basic Cube Query Using Source Objects**

```

// Get the SALES measure and the Source for it.
MdmBaseMeasure mdmSales = mdmUnitsCube.findOrCreateBaseMeasure("SALES");
NumberSource sales = (NumberSource)mdmSales.getSource();

// Get the Source objects for the PRODUCT_PRIMARY, CHANNEL_PRIMARY
// and the SHIPMENTS hierarchies.
StringSource prodHier = (StringSource)mdmProdHier.getSource();
    StringSource shipHier = (StringSource)mdmShipHier.getSource();
StringSource chanHier = (StringSource)mdmChanHier.getSource();

// Get the YEAR hierarchy level.
List<MdmHierarchyLevel> hierLevels = mdmCalHier.getLevels();
MdmHierarchyLevel mdmYearHierLevel = null;
for(MdmHierarchyLevel mdmHierLevel : hierLevels)
{
    mdmYearHierLevel = mdmHierLevel;
    if(mdmYearHierLevel.getName().equals("YEAR"))
    {
        break;
    }
}
// Get the Source for the YEAR level of the CALENDAR_YEAR hierarchy.
Source yearLevel = mdmYearHierLevel.getSource();

// Select single values for the hierarchies except for the time hierarchy.
Source prodSel = prodHier.selectValue("PRODUCT_PRIMARY::TOTAL_PRODUCT::TOTAL");
Source custSel = shipHier.selectValue("SHIPMENTS::TOTAL_CUSTOMER::TOTAL");

```

```
Source chanSel = chanHier.selectValue("CHANNEL_PRIMARY::TOTAL_CHANNEL::TOTAL");

// Get the long description attribute for the TIME_AWJ dimension.
MdmBaseAttribute mdmTimeLDAAttr = (MdmBaseAttribute)
    mdmTimeDim.getValueDescriptionAttribute();
Source timeLDAAttr = mdmTimeLDAAttr.getSource();

Source yearsWithLDValue = timeLDAAttr.join(yearLevel);

Source result = sales.joinHidden(prodSel)
    .joinHidden(custSel)
    .joinHidden(chanSel)
    .join(yearsWithLDValue);

getContext().commit();
getContext().displayResult(result);
```

The values of the Cursor for the result Source are the following. The code for formatting the values is not shown. For the complete code for [Example 2-4](#) (page 2-31) and [Example 2-5](#) (page 2-34), see the `BasicCubeViewQuery.java` example program.

Year	Sales
1998	100870876.58
1999	134109248.15
2000	124173521.55
2001	116931722.03
2002	92515295.02
2003	130276513.86
2004	144290685.55
2005	136986571.96
2006	140138317.39
2007	NA



---

## Discovering Metadata

This chapter describes how to connect to an Oracle Database instance and how to discover existing Oracle OLAP metadata objects. It includes the following topics:

- [Connecting to Oracle OLAP](#) (page 3-1)
- [Overview of the Procedure for Discovering Metadata](#) (page 3-3)
- [Creating an MdmMetadataProvider](#) (page 3-4)
- [Getting the MdmSchema Objects](#) (page 3-5)
- [Getting the Contents of an MdmSchema](#) (page 3-6)
- [Getting the Objects Contained by an MdmPrimaryDimension](#) (page 3-7)
- [Getting the Source for a Metadata Object](#) (page 3-9)

### 3.1 Connecting to Oracle OLAP

To connect to the Oracle OLAP server in an Oracle Database instance, an OLAP Java API client application uses the Oracle implementation of the Java Database Connectivity (JDBC) API. The Oracle JDBC classes that you use to establish a connection to Oracle OLAP are in the Java archive file `ojdbc6.jar`. For information about getting that file, see [Setting Up the Development Environment](#) (page A-1).

The following topics describe creating a connection to Oracle OLAP.

- [Prerequisites for Connecting](#) (page 3-1)
- [Establishing a Connection](#) (page 3-2)
- [Closing the Connection and the DataProvider](#) (page 3-3)

#### 3.1.1 Prerequisites for Connecting

Before attempting to connect to the Oracle OLAP server, ensure that the following requirements are met:

- The Oracle Database instance is running and was installed with the OLAP option.
- The Oracle Database user ID that you are using for the connection has access to the relational schemas that contain the data.
- The Oracle JDBC and OLAP Java API jar files are in your application development environment. For information about setting up the required jar files, see [Setting Up the Development Environment](#) (page A-1).

## 3.1.2 Establishing a Connection

To connect to the OLAP server, perform the following steps:

1. Create a JDBC connection to the database.
2. Create a `DataProvider` and a `UserSession`.

These steps are described in the following topics:

- [Creating a JDBC Connection](#) (page 3-2)
- [Creating a DataProvider and a UserSession](#) (page 3-2)

### 3.1.2.1 Creating a JDBC Connection

One way to create a connection to an Oracle Database instance is to use `oracle.jdbc.OracleDataSource` and `oracle.jdbc.OracleConnection` objects. For example, the following code creates an `oracle.jdbc.OracleDataSource`, sets properties of the object, and then gets a JDBC `OracleConnection` object from the `OracleDataSource`.

The values of the properties for the `OracleDataSource` are from a `java.util.Properties` object. The `url` property has the form `jdbc:oracle:thin:@serverName:portNumber:sid`, where `serverName` is the hostname of the server on which the Oracle Database instance is running, `portNumber` is the number of the TCP/IP listener port for the database, and `sid` is the system identifier (SID) of the database instance.

#### **Example 3-1 Getting a JDBC OracleConnection**

```
oracle.jdbc.OracleConnection conn = null;
try
{
    OracleDataSource ods = new OracleDataSource();
    ods.setURL(props.getProperty("url"));
    ods.setUser(props.getProperty("user"));
    ods.setPassword(props.getProperty("password"));
    conn = (oracle.jdbc.OracleConnection) ods.getConnection();
}
catch(SQLException e)
{
    System.out.println("Connection attempt failed. " + e);
}
```

In the example, the connection uses the Oracle JDBC thin driver. There are many ways to specify your connection characteristics using the `getConnection` method. There are also other ways to connect to an Oracle Database instance. For more information about Oracle JDBC connections, see *Oracle Database JDBC Developer's Guide*.

After you have the `OracleConnection` object, you can create OLAP Java API `DataProvider` and `UserSession` objects.

### 3.1.2.2 Creating a DataProvider and a UserSession

The following code creates a `DataProvider` and a `UserSession`. The `conn` object is the `OracleConnection` from [Example 3-1](#) (page 3-2).

**Example 3-2 Creating a DataProvider**

```

DataProvider dp = new DataProvider();
try
{
    UserSession session = dp.createSession(conn);
}
catch(SQLException e)
{
    System.out.println("Could not create a UserSession. " + e);
}

```

Using the `DataProvider`, you can get the `MdmMetadataProvider`, which is described in ["Creating an MdmMetadataProvider" \(page 3-4\)](#). You use the `DataProvider` to get the `TransactionProvider` and to create `Source` and `CursorManager` objects as described in [Understanding Source Objects \(page 5-1\)](#) and [Making Queries Using Source Methods \(page 6-1\)](#).

**3.1.3 Closing the Connection and the DataProvider**

If you are finished using the OLAP Java API, but you want to continue working in your JDBC connection to the database, then use the `close` method of your `DataProvider` to release the OLAP Java API resources.

```
dp.close();    // dp is the DataProvider
```

When you have completed your work with the database, use the `OracleConnection.close` method.

**Example 3-3 Closing the Connection**

```

try
{
    conn.close();    // conn is the OracleConnection
}
catch(SQLException e)
{
    System.out.println("Cannot close the connection. " + e);
}

```

**3.2 Overview of the Procedure for Discovering Metadata**

The OLAP Java API provides access to the data of an analytic workspace or that is in relational structures. This collection of data is the data store for the application.

Potentially, the data store includes all of the subschemas of the `MdmRootSchema`. However, the scope of the data store that is visible when an application is running depends on the database privileges that apply to the user ID through which the connection was made. A user can see all of the `MdmDatabaseSchema` objects that exist under the `MdmRootSchema`, but the user can see the objects that are owned by an `MdmDatabaseSchema` only if the user has access rights to the metadata objects. For information on granting access rights and on object security, see *Oracle OLAP User's Guide*.

The following topics describe discovering metadata.

- [Purpose of Discovering the Metadata \(page 3-4\)](#)
- [Steps in Discovering the Metadata \(page 3-4\)](#)

### 3.2.1 Purpose of Discovering the Metadata

The metadata objects in the data store help your application to make sense of the data. They provide a way for you to find out what data is available, how it is structured, and what the characteristics of it are.

Therefore, after connecting, your first step is to find out what metadata is available. You can then present choices to the end user about what data to select or calculate and how to display it.

After an application discovers the metadata, it typically goes on to create queries for selecting, calculating, and otherwise manipulating the data. To work with data in these ways, you must get the `Source` objects from the metadata objects. These `Source` objects specify the data for querying. For more information on `Source` objects, see [Understanding Source Objects](#) (page 5-1).

### 3.2.2 Steps in Discovering the Metadata

Before investigating the metadata, your application must make a connection to Oracle OLAP. Then, your application might perform the following steps:

1. Create a `DataProvider`.
2. Get the `MdmMetadataProvider` from the `DataProvider`.
3. Get the `MdmRootSchema` from the `MdmMetadataProvider`.
4. Get all of the `MdmDatabaseSchema` objects or get individual ones.
5. Get the `MdmCube`, `MdmDimension`, and `MdmOrganizationalSchema` objects owned by the `MdmDatabaseSchema` objects.

The following topics describe these steps in detail.

- [Creating an MdmMetadataProvider](#) (page 3-4)
- [Getting the MdmSchema Objects](#) (page 3-5)
- [Getting the Contents of an MdmSchema](#) (page 3-6)
- [Getting the Objects Contained by an MdmPrimaryDimension](#) (page 3-7)

## 3.3 Creating an MdmMetadataProvider

An `MdmMetadataProvider` gives access to the metadata in a data store by providing the `MdmRootSchema`. Before you can create an `MdmMetadataProvider`, you must create a `DataProvider` as described in [Creating Metadata and Analytic Workspaces](#) (page 4-1). [Example 3-4](#) (page 3-4) creates an `MdmMetadataProvider`. In the example, `dp` is the `DataProvider`.

#### **Example 3-4** *Creating an MdmMetadataProvider*

```
MdmMetadataProvider mp = null;
try
{
    mp = (MdmMetadataProvider) dp.getMdmMetadataProvider();
}
catch (Exception e)
{
```



```

        println("Cannot get the MDM metadata provider. " + e);
    }

```

### 3.4 Getting the MdmSchema Objects

The Oracle OLAP metadata objects that provide access to the data in a data store are organized by MdmSchema objects. The top-level MdmSchema is the MdmRootSchema. Getting the MdmRootSchema is the first step in exploring the metadata in your data store. From the MdmRootSchema, you can get the MdmDatabaseSchema objects. The MdmRootSchema has an MdmDatabaseSchema for each database user. An MdmDatabaseSchema can have MdmOrganizationalSchema objects that organize the metadata objects owned by the MdmDatabaseSchema.

#### **Example 3-5 Getting the MdmSchema Objects**

This example demonstrates getting the MdmRootSchema, the MdmDatabaseSchema objects under it, and any MdmOrganizationalSchema objects under them.

```

private void getSchemas(MdmMetadataProvider mp)
{
    MdmRootSchema mdmRootSchema = (MdmRootSchema)mp.getRootSchema();
    List<MdmDatabaseSchema> dbSchemas = mdmRootSchema.getDatabaseSchemas();
    for(MdmDatabaseSchema mdmDBSchema : dbSchemas)
    {
        println(mdmDBSchema.getName());
        getOrgSchemas(mdmDBSchema);
    }
}

private void getOrgSchemas(MdmSchema mdmSchema)
{
    ArrayList orgSchemaList = new ArrayList();

    if (mdmSchema instanceof MdmDatabaseSchema)
    {
        MdmDatabaseSchema mdmDBSchema = (MdmDatabaseSchema) mdmSchema;
        orgSchemaList = (ArrayList) mdmDBSchema.getOrganizationalSchemas();
    }
    else if (mdmSchema instanceof MdmOrganizationalSchema)
    {
        MdmOrganizationalSchema mdmOrgSchema = (MdmOrganizationalSchema)
            mdmSchema;
        orgSchemaList = (ArrayList) mdmOrgSchema.getOrganizationalSchemas();
    }

    if (orgSchemaList.size() > 0)
    {
        println("The MdmOrganizationalSchema subschemas of "
            + mdmSchema.getName() + " are:");
        Iterator orgSchemaListItr = orgSchemaList.iterator();
        while (orgSchemaListItr.hasNext())
        {
            MdmOrganizationalSchema mdmOrgSchema = (MdmOrganizationalSchema)
                orgSchemaListItr.next();

            println(mdmOrgSchema.getName());
            getOrgSchemas(mdmOrgSchema);
        }
    }
    else
    {
        println(mdmSchema.getName() + " does not have any" +

```

```
        " MdmOrganizationalSchema subschemas.");  
    }  
}
```

### **Example 3-6 Getting a Single MdmDatabaseSchema**

Rather than getting all of the `MdmDatabaseSchema` objects, you can use the `getDatabaseSchema` method of the `MdmRootSchema` to get the schema for an individual user. This example demonstrates getting the `MdmDatabaseSchema` for the GLOBAL user.

```
MdmDatabaseSchema mdmGlobalSchema = mdmRootSchema.getDatabaseSchema("GLOBAL");
```

## 3.5 Getting the Contents of an MdmSchema

From an `MdmSchema`, you can get all of the subschema, `MdmCube`, `MdmPrimaryDimension`, and `MdmMeasure` objects that it contains. Also, the `MdmRootSchema` has an `MdmMeasureDimension` that has a `List` of all of the available `MdmMeasure` objects.

If you want to display all of the dimensions and methods that are owned by a particular user, then you could get the lists of dimensions and measures from the `MdmDatabaseSchema` for that user.

### **Example 3-7 Getting the Dimensions and Measures of an MdmDatabaseSchema**

This example gets the dimensions and measures from the `MdmDatabaseSchema` from [Example 3-6](#) (page 3-6). It displays the name of each dimension and measure.

```
private void getObjects(MdmDatabaseSchema mdmGlobalSchema)  
{  
    List dimList = mdmGlobalSchema.getDimensions();  
    String objName = mdmGlobalSchema.getName() + " schema";  
    getNames(dimList, "dimensions", objName);  
  
    List measList = mdmGlobalSchema.getMeasures();  
    getNames(measList, "measures", objName);  
}  
  
private void getNames(List objectList, String objTypes, String objName)  
{  
    println("The " + objTypes + " of the " + objName + " are:");  
    Iterator objListItr = objectList.iterator();  
    while (objListItr.hasNext())  
    {  
        MdmObject mdmObj = (MdmObject) objListItr.next();  
        println(mdmObj.getName());  
    }  
}
```

The output of the example is the following.

```
The dimensions of the GLOBAL schema are:  
CHANNEL_AWJ  
CUSTOMER_AWJ  
PRODUCT_AWJ  
TIME_AWJ  
The measures of the GLOBAL schema are:  
UNIT_COST  
UNIT_PRICE  
SALES
```

```
UNITS
COST
```

### Example 3-8 Getting the Dimensions and Measures of an MdmCube

To display just the dimensions and measures associated with an `MdmCube`, you could use the `findOrCreateCube` method of an `MdmDatabaseSchema` to get the cube and then get the dimensions and measures of the cube. This example gets an `MdmCube` from the `MdmDatabaseSchema` of [Example 3-6](#) (page 3-6) and displays the names of the dimensions and measures associated with it using the `getNames` method of [Example 3-7](#) (page 3-6).

```
private void getCubeObjects(MdmDatabaseSchema mdmGlobalSchema)
{
    MdmCube mdmUnitsCube = (MdmCube)
        mdmGlobalSchema.findOrCreateCube("PRICE_CUBE_AWJ");
    String objName = mdmUnitsCube.getName() + " cube";
    List dimList = mdmUnitsCube.getDimensions();
    getNames(dimList, "dimensions", objName);

    List<MdmMeasure> measList = mdmUnitsCube.getMeasures();
    getNames(measList, "measures", objName);
}
```

The output of the example is the following.

```
The dimensions of the PRICE_CUBE_AWJ cube are:
TIME_AWJ
PRODUCT_AWJ
The measures of the PRICE_CUBE_AWJ cube are:
UNIT_COST
UNIT_PRICE
```

## 3.6 Getting the Objects Contained by an MdmPrimaryDimension

In discovering the metadata objects to use in creating queries and displaying the data, an application typically gets the `MdmSubDimension` components of an `MdmPrimaryDimension` and the `MdmAttribute` objects that are associated with the dimension. The following topics demonstrate getting the components and attributes of a dimension.

- [Getting the Hierarchies and Levels of an MdmPrimaryDimension](#) (page 3-7)
- [Getting the Attributes for an MdmPrimaryDimension](#) (page 3-8)

### 3.6.1 Getting the Hierarchies and Levels of an MdmPrimaryDimension

An `MdmPrimaryDimension` has zero or more component `MdmHierarchy` objects, which you can obtain by calling the `getHierarchies` method of the dimension. That method returns a `List` of `MdmHierarchy` objects. The levels of an `MdmPrimaryDimension` are represented by `MdmDimensionLevel` objects.

If an `MdmHierarchy` is an `MdmLevelHierarchy`, then it has `MdmHierarchyLevel` objects that associate `MdmDimensionLevel` objects with it. You can obtain the `MdmHierarchyLevel` objects by calling the `getHierarchyLevels` method of the `MdmLevelHierarchy`.

**Example 3-9 Getting the Hierarchies and Levels of a Dimension**

This example gets an `MdmPrimaryDimension` from the `MdmDatabaseSchema` of [Example 3-6](#) (page 3-6) and displays the names of the hierarchies and the levels associated with them.

```
private void getHierarchiesAndLevels(MdmDatabaseSchema mdmGlobalSchema)
{
    MdmPrimaryDimension mdmCustDim = (MdmPrimaryDimension)
        mdmGlobalSchema.findOrCreateStandardDimension("CUSTOMER_AWJ");
    List<MdmHierarchy> hierList = mdmCustDim.getHierarchies();
    println("The hierarchies of the dimension are:");
    for (MdmHierarchy mdmHier : hierList)
    {
        println(mdmHier.getName());
        if (mdmHier instanceof MdmLevelHierarchy)
        {
            MdmLevelHierarchy mdmLevelHier = (MdmLevelHierarchy) mdmHier;
            List<MdmHierarchyLevel> hierLevelList = mdmLevelHier.getHierarchyLevels();
            println(" The levels of the hierarchy are:");
            for (MdmHierarchyLevel mdmHierLevel : hierLevelList)
            {
                println(" " + mdmHierLevel.getName());
            }
        }
    }
}
```

The output of [Example 3-9](#) (page 3-8) is the following.

```
The hierarchies of the dimension are:
SHIPMENTS
  The levels of the hierarchy are:
  TOTAL_CUSTOMER
  REGION
  WAREHOUSE
  SHIP_TO
MARKETS
  The levels of the hierarchy are:
  TOTAL_MARKET
  MARKET_SEGMENT
  ACCOUNT
  SHIP_TO
```

**3.6.2 Getting the Attributes for an MdmPrimaryDimension**

An `MdmPrimaryDimension` and the hierarchies and levels of it have associated `MdmAttribute` objects. You can obtain many of the attributes by calling the `getAttributes` method of the dimension, hierarchy, or level. That method returns a `List` of `MdmAttribute` objects that an application has explicitly added to or specified for the `MdmPrimaryDimension`. You can obtain specific attributes, such as a short or long description attribute or a parent attribute by calling the appropriate method of an `MdmPrimaryDimension` or an `MdmHierarchy`.

**Example 3-10 Getting the MdmAttribute Objects of an MdmPrimaryDimension**

This example demonstrates getting the `MdmAttribute` objects for an `MdmPrimaryDimension`. It also gets the parent attribute separately. The example displays the names of the `MdmAttribute` objects. The attribute names that end in `_LD` and `_SD` are the attributes that are added to the `MdmHierarchyLevel` objects, as

mentioned in "[Populating OLAP Views with Hierarchical Attribute Values](#) (page 2-26)".

```
private void getAttributes(MdmDatabaseSchema mdmGlobalSchema)
{
    MdmTimeDimension mdmTimeDim = (MdmTimeDimension)
        mdmGlobalSchema.findOrCreateTimeDimension("TIME_AWJ");
    List attrList = mdmTimeDim.getAttributes();
    Iterator attrListItr = attrList.iterator();
    println("The MdmAttribute objects of " + mdmTimeDim.getName() + " are:");
    while (attrListItr.hasNext())
    {
        MdmAttribute mdmAttr = (MdmAttribute) attrListItr.next();
        println("  " + mdmAttr.getName());
    }

    MdmAttribute mdmParentAttr = mdmTimeDim.getParentAttribute();
    println("The parent attribute is " + mdmParentAttr.getName() + ".");
}
```

The output of the example is the following.

The MdmAttribute objects of TIME\_AWJ are:

```
LONG_DESCRIPTION
SHORT_DESCRIPTION
END_DATE
TIME_SPAN
TOTAL_TIME_LD
YEAR_LD
QUARTER_LD
MONTH_LD
TOTAL_TIME_SD
YEAR_SD
QUARTER_SD
MONTH_SD
TOTAL_TIME_ED
YEAR_ED
QUARTER_ED
MONTH_ED
TOTAL_TIME_TS
YEAR_TS
QUARTER_TS
MONTH_TS
```

The parent attribute is PARENT\_ATTRIBUTE.

### 3.7 Getting the Source for a Metadata Object

A metadata object represents a set of data, but it does not provide the ability to create queries on that data. The object is informational. It records the existence, structure, and characteristics of the data. It does not give access to the data values.

To access the data values for a metadata object, an application gets the *Source* object for that metadata object. The *Source* for a metadata object is a primary *Source*.

To get the primary *Source* for a metadata object, an application calls the `getSource` method of that metadata object. For example, if an application needs to display the quantity of product units sold during the year 1999, then it must use the `getSource` method of the `MdmMeasure` for that data, which is `mdmUnits` in the following example.

**Example 3-11** *Getting a Primary Source for a Metadata Object*

```
Source units = mdmUnits.getSource();
```

For more information about getting and working with primary Source objects, see [Understanding Source Objects](#) (page 5-1).

---

# Creating Metadata and Analytic Workspaces

This chapter describes how to create new metadata objects and map them to relational structures or expressions. It describes how to export and import the definitions of the metadata objects to XML templates. It also describes how to associate the objects with an analytic workspace, and how to build the analytic workspace.

The examples in this chapter are from the `CreateMetadataAndAW.java` example program. That program creates some of the same metadata objects as the `CreateAndBuildAW.java` and `SpecifyAWValues.java` example programs. The `CreateMetadataAndAW` program also exports the analytic workspace to an XML template.

This chapter includes the following topics:

- [Overview of Creating and Mapping Metadata](#) (page 4-1)
- [Creating an Analytic Workspace](#) (page 4-2)
- [Creating the Dimensions, Levels, and Hierarchies](#) (page 4-2)
- [Creating Attributes](#) (page 4-7)
- [Creating Cubes and Measures](#) (page 4-8)
- [Committing Transactions](#) (page 4-10)
- [Exporting and Importing XML Templates](#) (page 4-11)
- [Building an Analytic Workspace](#) (page 4-11)

## 4.1 Overview of Creating and Mapping Metadata

The OLAP Java API provides the ability to create persistent metadata objects. The top-level metadata objects exist in the data dictionary of the Oracle Database instance. The API also provides the ability to create transient metadata objects that exist only for the duration of the session. An application can use both types of metadata objects to create queries that retrieve or otherwise use the data in the data store.

Before an OLAP Java API application can create metadata objects, a database administrator must have prepared the Oracle Database instance. The DBA must have set up permanent and temporary tablespaces in the database to support the creation of Oracle OLAP metadata objects and must have granted the privileges that allow the user of the session to create and manage objects. For information on preparing an Oracle Database instance, see *Oracle OLAP User's Guide*.

A dimensional metadata model typically includes the objects described in [Understanding OLAP Java API Metadata](#) (page 2-1). For detailed information on designing a dimensional metadata model, see *Oracle OLAP User's Guide*.

You implement the dimensional model by creating OLAP Java API metadata objects. You use classes in the `oracle.olapi.metadata.mapping` package to map the metadata objects to relational source objects and to build analytic workspaces. You use classes in the `oracle.olapi.syntax` package to specify `Expression` objects that you use in mapping the metadata. You use classes in the `oracle.olapi.metadata.deployment` package to deploy the metadata objects in an analytic workspace or in a relational database (ROLAP) organization.

The basic steps for implementing the dimensional model as OLAP Java API objects in an analytic workspace are the following:

1. Create an `AW` object and `MdmPrimaryDimension` and `MdmCube` objects.
2. Deploy the `MdmPrimaryDimension` and `MdmCube` objects to the AW.
3. Create `MdmDimensionLevel`, `MdmHierarchy`, and `MdmAttribute` objects for each `MdmPrimaryDimension`, create `MdmHierarchyLevel` objects to associate `MdmDimensionLevel` objects with an `MdmHierarchy`, and create the `MdmMeasure` and related objects for the `MdmCube` objects.
4. Map the metadata objects to the relational sources of the base data.
5. Commit the `Transaction`, which creates persistent objects in the database.
6. Load data into the objects from the relational sources by building the analytic workspace.

For a list of the topics that describe these steps, see [Creating Metadata and Analytic Workspaces](#) (page 4-1).

## 4.2 Creating an Analytic Workspace

An analytic workspace is a container for dimensional objects. It is represented by the `AW` class in the `oracle.olapi.metadata.deployment` package. An analytic workspace is owned by an `MdmDatabaseSchema`.

**Example 4-1** (page 4-2) demonstrates getting the `MdmDatabaseSchema` for the GLOBAL user and creating an AW. For an example that gets the `MdmRootSchema`, see [Discovering Metadata](#) (page 3-1).

### **Example 4-1** Creating an AW

```
private void createAW(MdmRootSchema mdmRootSchema)
{
    MdmDatabaseSchema mdmDBSchema = mdmRootSchema.getDatabaseSchema("GLOBAL");
    aw = mdmDBSchema.findOrCreateAW("GLOBAL_AWJ");
}
```

## 4.3 Creating the Dimensions, Levels, and Hierarchies

A dimension is a list of unique values that identify and categorize data. Dimensions form the edges of a cube and identify the values in the measures of the cube. A dimension can have one or more levels that categorize the dimension members. It can have one or more hierarchies that further categorize the members. A dimension can also have no levels or hierarchies. However, a dimension must have one or more levels before Oracle OLAP can create a materialized view for it.



A dimension also has attributes that contain information about dimension members. For descriptions of creating attributes, see "[Creating Attributes](#) (page 4-7)".

The following topics describe how to create objects that represent a dimension and the levels and hierarchies of a dimension.

- [Creating and Mapping Dimensions](#) (page 4-3)
- [Creating and Mapping Dimension Levels](#) (page 4-3)
- [Creating and Mapping Hierarchies](#) (page 4-4)

### 4.3.1 Creating and Mapping Dimensions

An OLAP dimension is represented by the `MdmPrimaryDimension` class. A dimension is owned by an `MdmDatabaseSchema`. You create a dimension with the `findOrCreateTimeDimension` or the `findOrCreateStandardDimension` method of the `MdmDatabaseSchema`. You can map a dimension that has no levels to a relational data source by creating a `MemberListMap` for the dimension.

[Example 4-2](#) (page 4-3) creates a standard dimension that has the name `CHANNEL_AWJ`. The example creates an `AWPrimaryDimensionOrganization` object to deploy the dimension in an analytic workspace. The `mdmDBSchema` and `aw` objects are created by [Example 4-1](#) (page 4-2). The last three lines call the methods of [Example 4-3](#) (page 4-3), [Example 4-4](#) (page 4-4), and [Example 4-9](#) (page 4-10), respectively.

#### **Example 4-2 Creating and Deploying an MdmStandardDimension**

```
MdmStandardDimension mdmChanDim =
    mdmDBSchema.findOrCreateStandardDimension("CHANNEL_AWJ");
AWPrimaryDimensionOrganization awChanDimOrg =
    mdmChanDim.findOrCreateAWPrimaryDimensionOrganization(aw);

createAndMapDimensionLevels(mdmChanDim);
createAndMapHierarchies();
commit(mdmChanDim);
```

### 4.3.2 Creating and Mapping Dimension Levels

An `MdmDimensionLevel` represents the members of a dimension that are at the same level. Typically, the members of a level are in a column in a dimension table in the relational source. A `MemberListMap` associates the `MdmDimensionLevel` with the relational source.

[Example 4-3](#) (page 4-3) creates two `MdmDimensionLevel` objects for the `CHANNEL_AWJ` dimension and maps the dimension levels to the key columns of the `GLOBAL.CHANNEL_DIM` table. The example also maps the long description attributes for the dimension levels to columns of that table. The long description attribute, `chanLongDescAttr`, is created by [Example 4-6](#) (page 4-7).

#### **Example 4-3 Creating and Mapping an MdmDimensionLevel**

```
private ArrayList<MdmDimensionLevel> dimLevelList = new ArrayList();
private ArrayList<String> dimLevelNames = new ArrayList();
private ArrayList<String> keyColumns = new ArrayList();
private ArrayList<String> lDescColNames = new ArrayList();

private void createAndMapDimensionLevels(MdmPrimaryDimension mdmChanDim)
{
    dimLevelNames.add("TOTAL_CHANNEL");
```

```

dimLevelNames.add("CHANNEL");

keyColumns.add("GLOBAL.CHANNEL_DIM.TOTAL_ID");
keyColumns.add("GLOBAL.CHANNEL_DIM.CHANNEL_ID");

lDescColNames.add("GLOBAL.CHANNEL_DIM.TOTAL_DSC");
lDescColNames.add("GLOBAL.CHANNEL_DIM.CHANNEL_DSC");

// Create the MdmDimensionLevel and MemberListMap objects.
int i = 0;
for(String dimLevelName : dimLevelNames)
{
    MdmDimensionLevel mdmDimLevel =
        mdmChanDim.findOrCreateDimensionLevel(dimLevelNames.get(i));
    dimLevelList.add(mdmDimLevel);

    // Create a MemberListMap for the dimension level.
    MemberListMap mdmDimLevelMemListMap =
        mdmDimLevel.findOrCreateMemberListMap();
    ColumnExpression keyColExp =
        (ColumnExpression)SyntaxObject.fromSyntax(keyColumns.get(i),
                                                    metadataProvider);
    mdmDimLevelMemListMap.setKeyExpression(keyColExp);
    mdmDimLevelMemListMap.setQuery(keyColExp.getQuery());

    // Create an attribute map for the Long Description attribute.
    AttributeMap attrMapLong =
        mdmDimLevelMemListMap.findOrCreateAttributeMap(chanLongDescAttr);

    // Create an expression for the attribute map.
    Expression lDescColExp =
        (Expression)SyntaxObject.fromSyntax(lDescColNames.get(i),
                                                    metadataProvider);
    attrMapLong.setExpression(lDescColExp);
    i++;
}
}

```

### 4.3.3 Creating and Mapping Hierarchies

An *MdmHierarchy* represents a hierarchy in the dimensional object model. An *MdmHierarchy* can be an instance of the *MdmLevelHierarchy* or the *MdmValueHierarchy* class. An *MdmLevelHierarchy* has an ordered list of *MdmHierarchyLevel* objects that relate *MdmDimensionLevel* objects to the hierarchy.

#### 4.3.3.1 Creating and Mapping an *MdmLevelHierarchy*

[Example 4-4](#) (page 4-4) creates a hierarchy for the CHANNEL\_AWJ dimension. It creates hierarchy levels for the hierarchy and associates attributes with the hierarchy levels. It also maps the hierarchy levels and the attributes to relational sources. The example uses the *ArrayList* objects from [Example 4-3](#) (page 4-3). It maps the *MdmHierarchyLevel* objects to the same relational source objects as the *MdmDimensionLevel* objects are mapped.

**Example 4-4** *Creating and Mapping MdmLevelHierarchy and MdmHierarchyLevel Objects*

```

private void createAndMapHierarchies()
{
    MdmLevelHierarchy mdmLevelHier =

```

```

mdmChanDim.findOrCreateLevelHierarchy("CHANNEL_PRIMARY");

// Create the MdmHierarchyLevel and HierarchyLevelMap objects.
int i = 0;
for(String dimLevelName : dimLevelNames)
{
    MdmDimensionLevel mdmDimLevel =
        mdmChanDim.findOrCreateDimensionLevel(dimLevelName);
    MdmHierarchyLevel mdmHierLevel =
        mdmLevelHier.findOrCreateHierarchyLevel(mdmDimLevel);
    HierarchyLevelMap hierLevelMap =
        mdmHierLevel.findOrCreateHierarchyLevelMap();
    ColumnExpression keyColExp =
        (ColumnExpression)SyntaxObject.fromSyntax(keyColumns.get(i),
                                                    metadataProvider);

    hierLevelMap.setKeyExpression(keyColExp);
    hierLevelMap.setQuery(keyColExp.getQuery());
    i++;
}
}

```

### 4.3.3.2 Creating and Mapping an MdmValueHierarchy

The GLOBAL\_AWJ analytic workspace that is used by the examples in this documentation does not have an `MdmPrimaryDimension` for which an `MdmValueHierarchy` would be sensible. The sample schema for the user SCOTT has a table that can serve as an example.

The SCOTT sample schema has a table named EMP. That table has columns for employees and for managers. You could create a dimension for employees. You could then create an `MdmValueHierarchy` in which you map the employee column as the base values for the hierarchy and you map the manager column as the parent relation, as shown in [Example 4-5](#) (page 4-5). To be able to create OLAP dimensions, the SCOTT user must be granted the `OLAP_USER` role and the `CREATE SESSION` privilege.

In the example, `mdmDBSchema` is the `MdmDatabaseSchema` for the SCOTT user, `dp` is the `DataProvider`, and `mp` is the `MdmMetadataProvider`. The example does not show the code for connecting to the database or getting the `DataProvider` and creating a `UserSession`, or getting the `MdmMetadataProvider`, the `MdmRootSchema`, or the `MdmDatabaseSchema`. The code is an excerpt from a class that extends the `BaseExample11g` example class. That class uses other example classes that have methods for committing the current `Transaction` and for displaying output. For the complete code, see the `CreateValueHierarchy.java` example program.

#### **Example 4-5** Creating an `MdmValueHierarchy`

```

// Create an analytic workspace object.
AW aw = mdmDBSchema.findOrCreateAW(awName);
// Create a dimension and deploy it to the analytic workspace.
MdmPrimaryDimension mdmEmpDim =
    mdmDBSchema.findOrCreateStandardDimension("EMP_DIM");
AWPrimaryDimensionOrganization awEmpDimOrg =
    mdmEmpDim.findOrCreateAWPrimaryDimensionOrganization(aw);

// Get the EMP table and the Query for the table.
MdmTable empTable = (MdmTable)mdmDBSchema.getTopLevelObject("EMP");
Query empQuery = empTable.getQuery();

// Create a value hierarchy.

```

```

MdmValueHierarchy mdmValHier =
    mdmEmpDim.findOrCreateValueHierarchy("EMPVALHIER");
// Create a map for the hierarchy.
SolvedValueHierarchyMap solvedValHierMap =
    mdmValHier.findOrCreateSolvedValueHierarchyMap();
// Specify the Query, the key expression and the parent key expression for
// the hierarchy.
solvedValHierMap.setQuery(empQuery);
Expression keyExp =
    (Expression)SyntaxObject.fromSyntax("SCOTT.EMP.EMPNO", mp);
solvedValHierMap.setKeyExpression(keyExp);
Expression parentExp =
    (Expression)SyntaxObject.fromSyntax("SCOTT.EMP.MGR", mp);
solvedValHierMap.setParentKeyExpression(parentExp);

// Create an attribute that relates a name to each dimension member.
MdmBaseAttribute mdmNameAttr =
    mdmEmpDim.findOrCreateBaseAttribute("EMP_NAME");
SQLDataType sdtVC2 = new SQLDataType("VARCHAR2");
mdmNameAttr.setSQLDataType(sdtVC2);
// Create an attribute map for the attribute.
AttributeMap attrMap =
    solvedValHierMap.findOrCreateAttributeMap(mdmNameAttr);
// Create and set an expression for the attribute map.
Expression exp = (Expression)
    SyntaxObject.fromSyntax("SCOTT.EMP.ENAME", mp);
attrMap.setExpression(exp);
mdmValHier.addAttribute(mdmNameAttr);

// Commit the Transaction before building the analytic workspace.
// The getContext method of BaseExample11g returns a Context11g object,
// which has a method that commits the Transaction.
getContext().commit();
BuildItem bldEmpDim = new BuildItem(mdmEmpDim);
ArrayList<BuildItem> items = new ArrayList();
items.add(bldEmpDim);
BuildProcess bldProc = new BuildProcess(items);

// Execute the build.
try
{
    dp.executeBuild(bldProc, 0);
}
catch (Exception ex)
{
    println("Could not execute the BuildProcess.");
    println("Caught: " + ex);
}

//Get the Source objects for the dimension, the hierarchy, and the attribute.
Source empDim = mdmEmpDim.getSource();
Source valHier = mdmValHier.getSource();
Source empNameAttr = mdmNameAttr.getSource();
// Get the parent attribute and get the Source for it.
MdmAttribute mdmParentAttr = mdmEmpDim.getParentAttribute();
Source parentAttr = mdmParentAttr.getSource();

Source parentByEmpByName = parentAttr.join(valHier.join(empNameAttr));
// Sort the values in ascending order by employee number of the managers.
Source sortedParentByEmpByName = parentByEmpByName.sortAscending();

```

```
// Commit the Transaction before creating a Cursor.
getContext().commit();
// The displayResult method of the Context11g object creates a Cursor and
// displays the results.
println("The managers of the employees are:");
getContext().displayResult(sortedParentByEmpByName);
```

The output of the example is the following. It shows the employee name, the employee ID and then the employee ID of the manager. The results are sorted by manager. The employee King does not have a parent and is the highest member of the hierarchy so the manager value for King is null, which appears as NA in the output.

```
The managers of the employees are:
1: ((SCOTT,EMPVALHIER::7788),EMPVALHIER::7566)
2: ((FORD,EMPVALHIER::7902),EMPVALHIER::7566)
3: ((ALLEN,EMPVALHIER::7499),EMPVALHIER::7698)
4: ((WARD,EMPVALHIER::7521),EMPVALHIER::7698)
5: ((MARTIN,EMPVALHIER::7654),EMPVALHIER::7698)
6: ((TURNER,EMPVALHIER::7844),EMPVALHIER::7698)
7: ((JAMES,EMPVALHIER::7900),EMPVALHIER::7698)
8: ((MILLER,EMPVALHIER::7934),EMPVALHIER::7782)
9: ((ADAMS,EMPVALHIER::7876),EMPVALHIER::7788)
10: ((JONES,EMPVALHIER::7566),EMPVALHIER::7839)
11: ((BLAKE,EMPVALHIER::7698),EMPVALHIER::7839)
12: ((CLARK,EMPVALHIER::7782),EMPVALHIER::7839)
13: ((SMITH,EMPVALHIER::7369),EMPVALHIER::7902)
14: ((KING,EMPVALHIER::7839),NA)
```

## 4.4 Creating Attributes

Attributes contain information about dimension members. An `MdmBaseAttribute` represents values that are based on relational source tables. An `MdmDerivedAttribute` represents values that Oracle OLAP derives from characteristics or relationships of the dimension members. For example, the `getParentAttribute` method of an `MdmPrimaryDimension` returns an `MdmDerivedAttribute` that records the parent of each dimension member.

You create a base attribute for a dimension with the `findOrCreateBaseAttribute` method. You can specify the data type of the attribute, although for many attributes Oracle OLAP can determine the data type from the attribute mapping. With the `setAllowAutoDataTypeChange` method, you can specify that Oracle OLAP determine the data type. Some attributes are used by the dimension in certain ways, such as to provide descriptions of dimension members or to provide date information that can be used in calculations. For example, you can specify an attribute for descriptions with the `setValueDescriptionAttribute` method of the dimension and you can specify an attribute that contains end date time period values with the `setEndDateAttribute` method of an `MdmTimeDimension`.

**Example 4-6** (page 4-7) creates a long description attribute for the `CHANNEL_AWJ` dimension and specifies it as the attribute that contains descriptions of the members of the dimension. The example specifies that Oracle OLAP automatically determines a SQL data type for the attribute.

### **Example 4-6** Creating an `MdmBaseAttribute`

```
private MdmBaseAttribute chanLongDescAttr = null;
private void createLongDescriptionAttribute(MdmPrimaryDimension mdmChanDim)
{
// Create the long description attribute and allow the automatic changing of
// the SQL data type.
```

```

chanLongDescAttr = mdmChanDim.findOrCreateBaseAttribute("LONG_DESCRIPTION");
chanLongDescAttr.setAllowAutoDataTypeChange(true);

// Specifies that the attribute contains descriptions of the dimension members.
mdmChanDim.setValueDescriptionAttribute(chanLongDescAttr);
}

```

An attribute can have different values for the members of different levels of the dimension. In that case the attribute has an attribute mapping for each level. [Example 4-3](#) (page 4-3) creates an `AttributeMap` for the long description attribute for each dimension level by calling the `findOrCreateAttributeMap` method of the `MemberListMap` for each dimension level. It specifies a different column for each attribute map.

## 4.5 Creating Cubes and Measures

A cube in a dimensional object model is represented by the `MdmCube` class. An `MdmCube` owns one or more `MdmMeasure` objects. It has a list of the `MdmPrimaryDimension` objects that dimension the measures.

An `MdmCube` has the following objects associated with it.

- `MdmPrimaryDimension` objects that specify the dimensionality of the cube.
- `MdmMeasure` objects that contain data that is identified by the dimensions.
- A `CubeOrganization` that specifies how the cube stores and manages the measure data.
- `CubeMap` objects that associate the cube with relational sources.
- A `ConsistentSolveSpecification` that specifies how to calculate, or solve, the aggregate level data.

The following examples demonstrate creating and mapping a cube and its measures .

- [Creating Cubes](#) (page 4-8)
- [Creating and Mapping Measures](#) (page 4-9)

### 4.5.1 Creating Cubes

#### **Example 4-7** *Creating and Mapping an MdmCube*

This example creates a cube and some of the objects associated with it. It creates an `MdmCube` that has the name `PRICE_CUBE_AWJ`. It also creates an `AWCubeOrganization` object to deploy the cube in an analytic workspace. The `mdmDBSchema` and `aw` objects are created by [Example 4-1](#) (page 4-2) and the `leafLevel` `ArrayList` is created in [Example 4-4](#) (page 4-4). The `mdmTimeDim` and `mdmProdDim` objects are dimensions of time periods and product categories. The `CreateAndBuildAW` program creates those dimensions. The last lines of the example call the methods in [Example 4-8](#) (page 4-9) and [Example 4-9](#) (page 4-10), respectively.

```

private MdmCube createAndMapCube(MdmPrimaryDimension mdmTimeDim,
                                MdmPrimaryDimension mdmProdDim)
{
    MdmCube mdmPriceCube = mdmDBSchema.findOrCreateCube("PRICE_CUBE_AWJ");
    // Add dimensions to the cube.
    mdmPriceCube.addDimension(mdmTimeDim);
}

```

```

mdmPriceCube.addDimension(mdmProdDim);

AWCubeOrganization awCubeOrg =
    mdmPriceCube.findOrCreateAWCubeOrganization(aw);
awCubeOrg.setMVOption(AWCubeOrganization.NONE_MV_OPTION);
awCubeOrg.setMeasureStorage(AWCubeOrganization.SHARED_MEASURE_STORAGE);
awCubeOrg.setCubeStorageType("NUMBER");

AggregationCommand aggCommand = new AggregationCommand("AVG");
ArrayList<ConsistentSolveCommand> solveCommands = new ArrayList();
solveCommands.add(aggCommand);
ConsistentSolveSpecification conSolveSpec =
    new ConsistentSolveSpecification(solveCommands);
mdmPriceCube.setConsistentSolveSpecification(conSolveSpec);

// Create and map the measures of the cube.
createAndMapMeasures(mdmPriceCube);
// Commit the Transaction.
commit(mdmPriceCube);
}

```

## 4.5.2 Creating and Mapping Measures

### *Example 4-8 Creating and Mapping Measures*

This example creates measures for a cube and maps the measures to fact tables in the relational database. The example uses the cube created by [Example 4-7](#) (page 4-8).

```

private void createAndMapMeasures(MdmCube mdmPriceCube)
{
    ArrayList<MdmBaseMeasure> measures = new ArrayList();
    MdmBaseMeasure mdmCostMeasure =
        mdmPriceCube.findOrCreateBaseMeasure("UNIT_COST");
    MdmBaseMeasure mdmPriceMeasure =
        mdmPriceCube.findOrCreateBaseMeasure("UNIT_PRICE");
    mdmCostMeasure.setAllowAutoDataTypeChange(true);
    mdmPriceMeasure.setAllowAutoDataTypeChange(true);
    measures.add(mdmCostMeasure);
    measures.add(mdmPriceMeasure);
    MdmTable priceCostTable =
        (MdmTable)mdmDBSchema.getTopLevelObject("PRICE_FACT");
    Query cubeQuery = priceCostTable.getQuery();
    ArrayList<String> measureColumns = new ArrayList();
    measureColumns.add("GLOBAL.PRICE_FACT.UNIT_COST");
    measureColumns.add("GLOBAL.PRICE_FACT.UNIT_PRICE");
    CubeMap cubeMap = mdmPriceCube.findOrCreateCubeMap();
    cubeMap.setQuery(cubeQuery);

    // Create MeasureMap objects for the measures of the cube and
    // set the expressions for the measures. The expressions specify the
    // columns of the fact table for the measures.
    int i = 0;
    for(MdmBaseMeasure mdmBaseMeasure : measures)
    {
        MeasureMap measureMap = cubeMap.findOrCreateMeasureMap(mdmBaseMeasure);
        Expression expr =
            (Expression)SyntaxObject.fromSyntax(measureColumns.get(i),
                                                metadataProvider);

        measureMap.setExpression(expr);
        i++;
    }
}

```

```

// Create CubeDimensionalityMap objects for the dimensions of the cube and
// set the expressions for the dimensions. The expressions specify the
// columns of the fact table for the dimensions.

ArrayList<String> factColNames = new ArrayList();
factColNames.add("GLOBAL.PRICE_FACT.MONTH_ID");
factColNames.add("GLOBAL.PRICE_FACT.ITEM_ID");
List<MdmDimensionality> mdmDimlty = mdmPriceCube.getDimensionality();
for (MdmDimensionality mdmDimlty: mdmDimlty)
{
    CubeDimensionalityMap cubeDimMap =
        cubeMap.findOrCreateCubeDimensionalityMap(mdmDimlty);
    MdmPrimaryDimension mdmPrimDim =
        (MdmPrimaryDimension)mdmDimlty.getDimension();
    String columnMap = null;
    if (mdmPrimDim.getName().startsWith("TIME"))
    {
        columnMap = factColNames.get(0);
        i = 0;
    }
    else// (mdmPrimDim.getName().startsWith("PRODUCT"))
    {
        columnMap = factColNames.get(1);
        i = 1;
    }
    Expression expr =
        (Expression)SyntaxObject.fromSyntax(columnMap,metadataProvider);
    cubeDimMap.setExpression(expr);

    // Associate the leaf level of the hierarchy with the cube.
    MdmHierarchy mdmDefHier = mdmPrimDim.getDefaultHierarchy();
    MdmLevelHierarchy mdmLevHier = (MdmLevelHierarchy)mdmDefHier;
    List<MdmHierarchyLevel> levHierList = mdmLevHier.getHierarchyLevels();
    // The last element in the list must be the leaf level of the hierarchy.
    MdmHierarchyLevel leafLevel = levHierList.get(levHierList.size() - 1);
    cubeDimMap.setMappedDimension(leafLevel);
}
}

```

## 4.6 Committing Transactions

To save a metadata object as a persistent entity in the database, you must commit the Transaction in which you created the object. You can commit a Transaction at any time. Committing the Transaction after creating a top-level object and the objects that it owns is a good practice.

[Example 4-9](#) (page 4-10) gets the TransactionProvider from the DataProvider for the session and commits the current Transaction.

### **Example 4-9** Committing Transactions

```

private void commit(MdmSource mdmSource)
{
    try
    {
        System.out.println("Committing the transaction for " +
            mdmSource.getName() + ".");
        (dp.getTransactionProvider()).commitCurrentTransaction();
    }
    catch (Exception ex)

```



```

    {
      System.out.println("Could not commit the Transaction. " + ex);
    }
  }
}

```

## 4.7 Exporting and Importing XML Templates

You can save the definition of a metadata object by exporting the object to an XML template. Exporting an object saves the definition of the object and the definitions of any objects that it owns. For example, if you export an `AW` object to XML, then the XML includes the definitions of any `MdmPrimaryDimension` and `MdmCube` objects that the `AW` owns, and the `MdmAttribute`, `MdmMeasure` and other objects owned by the dimensions and cubes.

You can import a metadata object definition as an XML template. After importing, you must build the object.

### **Example 4-10** *Exporting to an XML Template*

This example exports metadata objects to an XML template and saves it in a file. The code excerpt at the beginning of the example creates a `List` of the objects to export. It adds to the `List` the `aw` object, which is the analytic workspace created by [Example 4-1](#) (page 4-2). It then calls the `exportToXML` method.

```

... // In some method.
List objectsToExport = new ArrayList();
objectsToExport.add(aw);
exportToXML(objectsToExport, "globalawj.xml");
...
public void exportToXML(List objectsToExport, String fileName)
{
  try
  {
    PrintWriter writer = new PrintWriter(new FileWriter(filename));
    mp.exportFullXML(writer,          // mp is the MdmMetadataProvider
                    objectsToExport,
                    null,             // No Map for renaming objects
                    false);          // Do not include the owner name

    writer.close();
  }
  catch (IOException ie)
  {
    ie.printStackTrace();
  }
}

```

## 4.8 Building an Analytic Workspace

After creating and mapping metadata objects, or importing the XML definition of an object, you must perform the calculations that the objects specify and load the resulting data into physical storage structures.

[Example 4-11](#) (page 4-11) creates `BuildItem` objects for the dimensions and cubes of the analytic workspace. It creates a `BuildProcess` that specifies the `BuildItem` objects and passes the `BuildProcess` to the `executeBuild` method of the `DataProvider` for the session.

### **Example 4-11** *Building an Analytic Workspace*

```

BuildItem bldChanDim = new BuildItem(mdmChanDim);
BuildItem bldProdDim = new BuildItem(mdmProdDim);

```

```
BuildItem bldCustDim = new BuildItem(mdmCustDim);
BuildItem bldTimeDim = new BuildItem(mdmTimeDim);
BuildItem bldUnitsCube = new BuildItem(mdmUnitsCube);
BuildItem bldPriceCube = new BuildItem(mdmPriceCube);
ArrayList<BuildItem> items = new ArrayList();
items.add(bldChanDim);
items.add(bldProdDim);
items.add(bldCustDim);
items.add(bldTimeDim);
items.add(bldUnitsCube);
items.add(bldPriceCube);
BuildProcess bldProc = new BuildProcess(items);
try
{
    dp.executeBuild(bldProc, 0);
}
catch (Exception ex)
{
    System.out.println("Could not execute the BuildProcess." + ex);
}
```

---

# Understanding Source Objects

This chapter describes `Source` objects, which you use to specify a query. With a `Source`, you specify the data that you want to retrieve from the data store and the analytical or other operations that you want to perform on the data. [Making Queries Using Source Methods](#) (page 6-1), provides examples of using `Source` objects. [Creating Dynamic Queries](#) (page 10-1), describes using `Template` objects to make modifiable queries.

This chapter includes the following topics:

- [Overview of Source Objects](#) (page 5-1)
- [Kinds of Source Objects](#) (page 5-2)
- [Characteristics of Source Objects](#) (page 5-3)
- [Inputs and Outputs of a Source](#) (page 5-6)
- [Describing Parameterized Source Objects](#) (page 5-18)

## 5.1 Overview of Source Objects

You use `Source` objects to create a query that specifies the data that you want to retrieve from the database. As a query, a `Source` is similar to a SQL `SELECT` statement.

To create a query, you typically use the classes in the `oracle.olapi.metadata.mdm` package to get `MdmSource` objects that represent OLAP metadata objects. From an `MdmSource` object, you can get a `Source` object. You can also create other kinds of `Source` objects with methods of a `DataProvider`. You can then use these `Source` objects to create a query. To retrieve the data specified by the query, you create a `Cursor` for the `Source`.

With the methods of a `Source`, you can specify selections of dimension members, attribute values, or measure values. You can also specify operations on the elements of the `Source`, such as mathematical calculations, comparisons, and ordering, adding, or removing elements of a query.

The `Source` class has a few basic methods and many shortcut methods that use one or more of the basic methods. The most complex basic methods are the `join(Source joined, Source comparison, int comparisonRule, boolean visible)` method and the `recursiveJoin(Source joined, Source comparison, Source parent, int comparisonRule, boolean parentsFirst, boolean parentsRestrictedToBase, int maxIterations, boolean visible)` method. The many other signatures of the `join` and `recursiveJoin` methods are shortcuts for certain operations of the basic methods.

In this chapter, the information about the `join` method applies equally to the `recursiveJoin` method, except where otherwise noted. With the `join` method you

can relate the elements of one Source to those of another Source by joining a Source with an input to a Source that matches with that input. For example, to specify the dimension members that are required to retrieve the data of a measure that has the dimension as an input, you use a `join` method to relate the dimension members to the measure. The `join` method and the inputs of a Source are described in "[Inputs and Outputs of a Source](#) (page 5-6)".

A Source has certain characteristics, such as a type and a data type, and it can have one or more inputs or outputs. This chapter describes these concepts. It also describes the different kinds of Source objects and how you get them, and the `join` method and other Source methods and how you use those methods to specify a query.

## 5.2 Kinds of Source Objects

The kinds of Source objects that you use to specify data and to perform analysis, and the ways that you get them, are the following:

- Primary Source objects, which are returned by the `getSource` method of an `MdmSource` object such as an `MdmDimension` or an `MdmDimensionedObject`. A primary Source provides access to the data that the `MdmSource` represents. Getting primary Source objects is usually the first step in creating a query. You then typically select elements from the primary Source objects, thereby producing derived Source objects.
- Derived Source objects, which you get by calling some of the methods of a Source object. Methods such as `join` return a new Source that is derived from the Source on which you call the method. All queries on the data store, other than a simple list of values specified by the primary Source for an `MdmDimension`, are derived Source objects.
- Fundamental Source objects, which are returned by the `getSource` method of a `FundamentalMetadataObject`. These Source objects represent the OLAP Java API data types.
- List or range Source objects, which are returned by the `createConstantSource`, `createListSource`, or `createRangeSource` methods of a `DataProvider`. Typically, you use this kind of Source as the `joined` or `comparison` parameter to a `join` method.
- Empty, null, or void Source objects. The empty and void Source objects are returned by the `getEmptySource` or `getVoidSource` method of a `DataProvider`, and the null Source object is returned by the `nullSource` method of a Source. The empty Source has no elements. The void Source and a null Source each has one element that has the value of `null`. The difference between the void Source and a null Source is that the type of the void Source is the `FundamentalMetadataObject` for the Value data type and the type of a null Source is the Source whose `nullSource` method returned it. Typically, you use these kinds of Source objects as the `joined` or `comparison` parameter to a `join` method.
- Dynamic Source objects, which are returned by the `getSource` method of a `DynamicDefinition`. A dynamic Source is usually a derived Source. It is generated by a `Template`, which you use to create a dynamic query that you can revise after interacting with an end user.
- Parameterized Source objects, which are returned by the `createSource` methods of a `Parameter`. Like a list or range Source, you use a parameterized

Source as a parameter to the `join` method. Unlike a list or range `Source`, however, you can change the value that the `Parameter` represents after the join operation and thereby change the selection that the derived `Source` represents. You can create a `Cursor` for that derived `Source` and retrieve the results of the query. You can then change the value of the `Parameter`, and, without having to create a new `Cursor` for the derived `Source`, use that same `Cursor` to retrieve the results of the modified query.

The `Source` class has the following subclasses:

- `BooleanSource`
- `DateSource`
- `NumberSource`
- `StringSource`

These subclasses have different data types and implement `Source` methods that require those data types. Each subclass also implements methods unique to it, such as the `implies` method of a `BooleanSource` or the `indexOf` method of a `StringSource`.

## 5.3 Characteristics of Source Objects

A `Source` has a data type, a type, and an identifier (ID), and all `Source` objects except the empty `Source` have one or more elements. The following topics describe these concepts.

- [Elements and Values of a Source](#) (page 5-3)
- [Data Type of a Source](#) (page 5-3)
- [Type of a Source](#) (page 5-4)
- [Source Identification and SourceDefinition of a Source](#) (page 5-5)

Some `Source` objects have one or more inputs or outputs. Those complex concepts are discussed in "[Inputs and Outputs of a Source](#) (page 5-6)".

### 5.3.1 Elements and Values of a Source

All `Source` objects, except the empty `Source`, have one or more elements. An element of a `Source` has a value, which can be null. For example, the `Source` for the `MdmPrimaryDimension` object for the `CHANNEL_AWJ` dimension has four elements. The values of those elements are the unique values of the members of the dimension, which are the following.

```
CHANNEL_PRIMARY::CHANNEL::TOTAL
CHANNEL_PRIMARY::CHANNEL::CAT
CHANNEL_PRIMARY::CHANNEL::DIR
CHANNEL_PRIMARY::CHANNEL::INT
```

### 5.3.2 Data Type of a Source

The `FundamentalMetadataObject` class represents the data type of the values of the elements of an `MdmSource`. The data type of a `Source` is represented by a `fundamentalSource`. For example, a `BooleanSource` has elements that have `Java`

boolean values. The data type of a `BooleanSource` is the fundamental `Source` that represents OLAP Java API Boolean values.

To get the fundamental `Source` that represents the data type of a `Source`, call the `getDataType` method of the `Source`. You can also get a fundamental `Source` by calling the `getSource` method of a `FundamentalMetadataObject`.

The data type for a primary `Source` is related to the SQL data type of the associated metadata object. For example, an `MdmBaseAttribute` that has a SQL data type of `VARCHAR2(30)` would produce a `Source` whose data type is the fundamental `Source` that represents OLAP Java API String values. The following code gets that fundamental `Source`.

```
fmp.getStringDataType().getSource(); // fmp is the FundamentalMetadataProvider.
```

A typical use of a `Source` for a data type is as the comparison `Source` for a join or a recursive join operation. As such it represents the set of all values of that data type. For examples of the use of the `getDataType` method, see [Example 6-3](#) (page 6-6), [Example 6-5](#) (page 6-8), and [Example 6-11](#) (page 6-19).

### 5.3.3 Type of a Source

Along with a data type, a `Source` has a type, which is the `Source` from which the elements of the `Source` are drawn. The type of a `Source` determines whether the join method can match the `Source` with the input of another `Source`. The only `Source` that does not have a type is the fundamental `Source` for the OLAP Java API Value data type, which represents the set of all values, and from which all other `Source` objects ultimately descend. You can find the type by calling the `getType` method of a `Source`.

The type of a fundamental `Source` is the data type of the `Source`. The type of a list or range `Source` is the data type of the values of the elements of the list or range `Source`.

The type of a primary `Source` is one of the following:

- The fundamental `Source` that represents the data type of the values of the elements of the primary `Source`. For example, the type of the `Source` returned by the `getSource` method of a typical numeric `MdmMeasure` is the fundamental `Source` that represents the set of all OLAP Java API number values.
- The `Source` for the object that contains the primary `Source`. For example, the type of the `Source` returned by the `getSource` method of an `MdmLevelHierarchy` is the `Source` for the `MdmPrimaryDimension` that contains the hierarchy.

The type of a derived `Source` is one of the following:

- The base `Source`, which is the `Source` whose method returned the derived `Source`. A `Source` returned by the `alias`, `distinct`, `extract`, `join`, `recursiveJoin`, or `value` methods, or one of their shortcuts, has the base `Source` as the type.
- A fundamental `Source`. The type of the `Source` returned by methods such as `position` and `count` is the fundamental `Source` for the OLAP Java API Integer data type. The type of the `Source` returned by methods that make comparisons, such as `eq`, `le`, and so on, is the fundamental `Source` for the Boolean data type. The type of the `Source` returned by methods that perform aggregate functions, such as the `NumberSource` methods `total` and `average`, is a fundamental `Source` that represents the function.

A derived Source that has the base Source as the type is a subtype of the Source from which it is derived. A derived Source that has a fundamental Source as the type is a subtype of the fundamental Source. You can use the `isSubtypeOf` method to determine if a Source is a subtype of another Source.

For example, in [Example 5-1](#) (page 5-5) the `myList` object is a list Source. The example uses `myList` to select values from `prodHier`, a Source for an `MdmLevelHierarchy` of the `MdmPrimaryDimension` for the `PRODUCT_AWJ` dimension. In the example, `dp` is the `DataProvider`.

**Example 5-1 Using the `isSubtypeOf` Method**

```
Source myList = dp.createListSource(new String[] {
    "PRODUCT_PRIMARY::FAMILY::LTPC",
    "PRODUCT_PRIMARY::FAMILY::DTPC",
    "PRODUCT_PRIMARY::FAMILY::ACC",
    "PRODUCT_PRIMARY::FAMILY::MON"});

Source prodSel = prodHier.selectValues(myList);
if (prodSel.isSubtypeOf(prodHier))
    println("prodSel is a subtype of prodHier.");
else
    println("prodSel is not a subtype of prodHier.");
```

Because `prodSel` is a subtype of `prodHier`, the condition in the `if` statement is true and the example displays the following:

```
prodSel is a subtype of prodHier.
```

The type of `myList` is the fundamental `String` Source. The type of `prodHier` is the Source for the `PRODUCT_AWJ` dimension. The type of `prodSel` is `prodHier` because the elements of `prodSel` are derived from the elements of `prodHier`.

The supertype of a Source is the type of the type of a Source, and so on, up through the types to the Source for the fundamental `Value` data type. For example, the fundamental `Value` Source is the type of the fundamental `String` Source, which is the type of `prodHier`, which is the type of `prodSel`. The fundamental `Value` Source and the fundamental `String` Source are both supertypes of `prodSel`. The `prodSel` Source is a subtype of `prodHier`, and of the fundamental `String` Source, and of the fundamental `Value` Source.

### 5.3.4 Source Identification and SourceDefinition of a Source

A Source has an identification, an `ID`, which is a `String` that uniquely identifies it during the current connection to the database. You can get the identification by calling the `getID` method of a Source. For example, the following code gets the identification of the Source for the `MdmPrimaryDimension` for the `PRODUCT_AWJ` dimension and displays the value.

```
println("The Source ID of prodDim is " + prodDim.getID());
```

The preceding code displays the following:

```
The Source ID of prodDim is Hidden..GLOBAL.PRODUCT_AWJ
```

Each Source also has a `SourceDefinition` object, which records information about the Source. Oracle OLAP uses this information internally. For example, the `SourceDefinition` of a derived Source records the parameters of the join operation that produced the Source, such as the base Source, the joined Source, the comparison Source, the comparison rule, and the value of the `visible` parameter.

The `DynamicDefinition` class is a subclass of `SourceDefinition`. An OLAP Java API client application uses the `DynamicDefinition` of a `Template` to get the dynamic `Source` of the `Template`.

## 5.4 Inputs and Outputs of a Source

An input of a `Source` indicates that the elements of the `Source` have a relation to those of another `Source`. An output of a `Source` contains elements from which values of the `Source` with the output are derived. A `Source` with one or more outputs is somewhat like an array of arrays.

A `Source` can have inputs and it can have outputs. The inputs and the outputs of a `Source` are other `Source` objects.

The inputs and outputs of a base `Source` influence the elements of a `Source` that you derive from that base `Source`. To derive a `Source`, you use methods of the base `Source`. The derived `Source` can have outputs or inputs or both or neither, depending on the method and the parameters of the method.

Some `Source` methods, such as the `value` and `position` methods, return a `Source` that has an input. The `join` and `recursiveJoin` methods can return a `Source` that has an output. If the join operation involves a `Source` with an input and a `Source` that matches with that input, then the input acts as a filter in producing the elements of the derived `Source`.

The following topics describe the `join` method, the concepts of outputs and inputs, and the matching of inputs. They provide examples of producing `Source` objects that have outputs, `Source` objects that have inputs, and join operations that match an input with a `Source`.

- [Describing the join Method](#) (page 5-6)
- [Outputs of a Source](#) (page 5-8)
- [Inputs of a Source](#) (page 5-11)
- [Matching a Source with an Input](#) (page 5-13)

### 5.4.1 Describing the join Method

With the `join` method, you join the elements of one `Source` with those of another `Source` to produce a derived `Source`. The derived `Source` could have inputs or outputs. The elements of the derived `Source`, and whether it has any inputs or outputs, depend on the values of the parameters that you pass to the `join` method.

The full signature of the `join` method is the following.

```
Source join(Source joined,  
           Source comparison,  
           int comparisonRule,  
           boolean visible)
```

The `Source` on which you call the `join` method is the base of the join operation. The parameters of the method are the following.

#### 5.4.1.1 Describing the joined Parameter

The `joined` parameter is a `Source` object. The `join` method joins the elements of the base `Source` and the elements of the `joined Source`, with results that are determined by the values of the other `join` parameters. If the values of the `joined Source` are not



related to the values of the base `Source`, that is, if neither the joined `Source` nor the base `Source` matches with an input of the other, then the join produces a Cartesian product of the elements of the base and the joined `Source` objects. The examples in the "[Outputs of a Source](#) (page 5-8)" topic demonstrate this kind of join operation.

If the values of the joined `Source` are related to the values of the base `Source`, that is, if either the joined `Source` or the base `Source` is an input of the other, then the elements of the derived `Source` are the result of the matching of the input. The examples in "[Matching a Source with an Input](#) (page 5-13)" demonstrate this kind of join operation.

#### 5.4.1.2 Describing the comparison Parameter

The `comparison` parameter is another `Source` object. The join operation compares the values of the elements of the comparison `Source` to the values of the joined `Source`. The values that are the same in the joined and comparison objects participate in the join operation or are removed from participation, depending on the value of the `comparisonRule` parameter.

#### 5.4.1.3 Describing the comparisonRule Parameter

The value of the `comparisonRule` parameter specifies which values of the joined `Source` participate in the join operation. The `comparisonRule` value also determines the sort order of the participating values. The comparison rule is one of the static constant fields of the `Source` class. The basic comparison rules are the following.

- `COMPARISON_RULE_SELECT`, which specifies that only the elements of the joined `Source` that are also in the comparison `Source` participate in the join operation.
- `COMPARISON_RULE_REMOVE`, which specifies that only the elements of the joined `Source` that are not in the comparison `Source` participate in the join operation.

The other comparison rules are all select operations that sort the resulting values in various ways. Those rules are the following.

- `COMPARISON_RULE_ASCENDING`
- `COMPARISON_RULE_ASCENDING_NULLS_FIRST`
- `COMPARISON_RULE_ASCENDING_NULLS_LAST`
- `COMPARISON_RULE_DESCENDING`
- `COMPARISON_RULE_DESCENDING_NULLS_FIRST`
- `COMPARISON_RULE_DESCENDING_NULLS_LAST`

#### 5.4.1.4 Describing the visible Parameter

The `visible` parameter is a boolean value that specifies whether the joined `Source` appears as an output of the `Source` that is derived by the join operation. If the value of the `visible` parameter is `true`, then the derived `Source` has an output that contains the elements drawn from the joined `Source`. If the value is `false`, then the derived `Source` does not have an output for the joined `Source`.

## 5.4.2 Outputs of a Source

The `join` method returns a derived `Source` that has the values of the elements of the base `Source` that are specified by the parameters of the method. Those values are the base values of the derived `Source`.

If the value of the `visible` parameter of the `join` method is `true`, then the joined `Source` becomes an output of the derived `Source`. The elements of the derived `Source` then have the values of the output and the base values, as specified by the other parameters of the join operation.

A derived `Source` can have from zero to many outputs. A `Source` that is an output can itself have outputs. You can get the outputs of a `Source` by calling the `getOutputs` method, which returns a `List` of `Source` objects.

The examples in the following topics all have simple join operations that produce `Source` objects that have one or more outputs. Because none of the `Source` objects in the join operations have inputs, the values of the derived `Source` objects produced by the join operations are the Cartesian products of the base and the joined `Source` objects.

- [Producing a Source with an Output](#) (page 5-8)
- [Using `COMPARISON\_RULE\_SELECT`](#) (page 5-9)
- [Using `COMPARISON\_RULE\_REMOVE`](#) (page 5-9)
- [Producing a Source with Two Outputs](#) (page 5-10)
- [Hiding an Output](#) (page 5-11)

Very different results occur from a join operation that involves a `Source` that has an input and a `Source` that matches with that input. For examples of `Source` objects with inputs and the matching of inputs, see the following topics.

- [Inputs of a Source](#) (page 5-11)
- [Matching a Source with an Input](#) (page 5-13)

### 5.4.2.1 Producing a Source with an Output

#### **Example 5-2 A Simple Join That Produces a Source with an Output**

This example uses the simplest signature of the `join` method to produce a `Source` that has one output. The example creates a list `Source`, `letters`, that has three elements, the values of which are A, B, and C. It also creates a list `Source`, `names`, that has three elements, the values of which are Stephen, Leo, and Molly.

```
Source letters = dp.createListSource(new String[] {"A", "B", "C"});
Source names = dp.createListSource(new String[] {"Stephen", "Leo", "Molly"});
Source lettersWithNames = letters.join(names);
```

```
// Oracle OLAP translates this shortcut signature of the join method into the
// following full signature, where dp is the DataProvider for the session.
// Source letters.join(names,
//                          dp.getEmptySource(),
//                          Source.COMPARISON_RULE_REMOVE,
//                          true);
```

The `letters.join(names)` operation joins the elements of the base `Source`, `letters`, and the joined `Source`, `names`. Because the comparison `Source` has no elements, the join operation does not remove any of the elements that are in the joined `Source` in producing the derived `Source`. (The comparison `Source` is the empty `Source` that is returned by the `dp.getEmptySource()` parameter of the full `join` signature shown in the example.) The resulting derived `Source`, `lettersWithNames`, is the Cartesian product of the elements of the base `letters` and the joined `names`. Because both `letters` and `names` have three elements, the number of elements in `lettersWithNames` is nine.

Because the `visible` parameter of `letters.join(names)` is `true`, the derived `Source` has an output. Because no elements were removed from the joined `Source`, the derived `Source` has the values of all of the elements of the joined `Source`.

A `Cursor` for a `Source` has the same structure as the `Source`. A `Cursor` for the `lettersWithNames` `Source` has a `ValueCursor` for the base values of the derived `Source` and a `ValueCursor` for the output values. The following table presents the values of the `ValueCursor` objects. The table includes headings that are not in the `ValueCursor` objects.

Output Values	Base Values
Stephen	A
Stephen	B
Stephen	C
Leo	A
Leo	B
Leo	C
Molly	A
Molly	B
Molly	C

### 5.4.2.2 Using `COMPARISON_RULE_SELECT`

#### **Example 5-3** *A Simple Join That Selects Elements of the Joined Source*

This example demonstrates using a comparison `Source` that has values and the comparison rule `COMPARISON_RULE_SELECT`. The example uses the `letter` and `names` `Source` objects from [Example 5-2](#) (page 5-8) and adds the `someNames` `Source`. It uses `someNames` as the comparison `Source`. The output of the `Source` derived from the join operation has only the names that are in both the joined `Source` and the comparison `Source`.

```
Source someNames = dp.createListSource(new String[] {"Stephen", "Molly"});
Source lettersAndSelectedNames =
    letters.join(names, someNames, Source.COMPARISON_RULE_SELECT, true);
```

A `Cursor` for the `lettersAndSelectedNames` `Source` has the values specified by the `Source`. The following table presents the `Cursor` values and has headings added.

Output Values	Base Values
Stephen	A
Stephen	B
Stephen	C
Molly	A
Molly	B
Molly	C

### 5.4.2.3 Using `COMPARISON_RULE_REMOVE`

**Example 5-4 A Simple Join That Removes Elements of the Joined Source**

This example demonstrates using a comparison `Source` that has values and the comparison rule `COMPARISON_RULE_REMOVE`. That comparison rule removes from participation in the join operation those values that are the same in the joined and in the comparison `Source` objects. The output of the derived `Source` therefore has only the name from the joined `Source` that is not in the comparison `Source`.

The example has the same base, joined, and comparison `Source` objects as [Example 5-3](#) (page 5-9).

```
Source lettersAndNamesWithoutRemovedNames =
    letters.join(names,
                someNames,
                Source.COMPARISON_RULE_REMOVE,
                true);
```

A `Cursor` for the `lettersAndNamesWithoutRemovedNames` `Source` has the values specified by the `Source`. The following table presents the values and has headings added.

Output Values	Base Values
Leo	A
Leo	B
Leo	C

**5.4.2.4 Producing a Source with Two Outputs****Example 5-5 A Simple Join That Produces a Source with Two Outputs**

If you join a `Source` to a `Source` that has an output, and if the `visible` parameter is `true`, then the join operation produces a `Source` that has the joined `Source` as an additional output. The additional output becomes the first output, as shown in this example.

The example uses the `Source` objects from [Example 5-3](#) (page 5-9) and creates another list `Source`, `colors`, that contains the names of two colors. The example joins the `colors` `Source` to the `lettersWithSelectedNames` `Source` to produce the `lettersWithSelectedNamesAndColors` `Source`.

The `lettersWithSelectedNames` `Source` has `names` as an output. The `lettersWithSelectedNamesAndColors` `Source` has both `colors` and `names` as outputs. The first output is `colors` and the second output is `names`.

```
Source colors = dp.createListSource(new String[] {"Green", "Maroon"});
```

```
Source lettersWithSelectedNames =
    letters.join(names,
                someNames,
                Source.COMPARISON_RULE_SELECT,
                true);
Source lettersWithSelectedNamesAndColors =
    lettersWithSelectedNames.join(colors);
```

A `Cursor` for the `lettersWithSelectedNamesAndColors` `Source` has the values shown in the following table. The table has headings added.

Output 1 Values	Output 2 Values	Base Values
Green	Stephen	A
Green	Stephen	B
Green	Stephen	C
Green	Molly	A

Green	Molly	B
Green	Molly	C
Maroon	Stephen	A
Maroon	Stephen	B
Maroon	Stephen	C
Maroon	Molly	A
Maroon	Molly	B
Maroon	Molly	C

### 5.4.2.5 Hiding an Output

#### **Example 5-6 A Simple Join That Hides An Output**

If the `visible` parameter of a `join` method is `false`, then the joined `Source` participates in the join operation but does not appear as an output of the `Source` derived by the join. This example uses the `joinHidden` shortcut method to join the `lettersWithSelectedNames` and the `colors` `Source` objects from [Example 5-5](#) (page 5-10). The example includes in a comment the full `join` signature for the `joinHidden` shortcut.

```
Source lettersWithSelectedNamesAndHiddenColors =
    lettersWithSelectedNames.joinHidden(colors);

// The full signature of the joinHidden shortcut method is
// Source result = base.join(joined,
//                             dp.getEmptySource(),
//                             Source.COMPARISON_RULE_REMOVE,
//                             false);
// So if Source base = lettersWithSelectedNames and
// Source joined = colors, then the result Source is the same as the
// lettersWithSelectedNamesAndHiddenColors Source.
```

A `Cursor` for the `lettersWithSelectedNamesAndHiddenColors` `Source` has the values shown in the following table. The table has headings added.

Note that the derived `lettersWithSelectedNamesAndHiddenColors` `Source` still has twelve elements, even though the values for the `colors` `Source` do not appear as output values. The derived `Source` has one set of the six values of the `lettersWithSelectedNames` `Source` for each value of the hidden `colors` `Source`.

The example displays the following output.

Output Values	Base Values
Stephen	A
Stephen	B
Stephen	C
Molly	A
Molly	B
Molly	C
Stephen	A
Stephen	B
Stephen	C
Molly	A
Molly	B
Molly	C

## 5.4.3 Inputs of a Source

The examples in the "[Outputs of a Source](#) (page 5-8)" topic all produce derived `Source` objects that have elements that are the Cartesian product of the unrelated base

and joined `Source` objects. While such an operation can be useful, a more powerful aspect of `Source` objects is the ability to relate the elements of one `Source` to another `Source`. When such a relationship exists, you can derive other `Source` objects that are the result of operations between the related elements. For example, you can derive a `Source` that contains only selected elements of another `Source`. This relationship between elements is represented by the input of a `Source`.

A `Source` with an input is an incomplete specification of data. The input represents the type of `Source` that can have the elements that a join operation requires to complete the data specification. Before you can retrieve the data with a `Cursor`, you must match the input with a `Source` that has the elements that complete the specification.

You match an input with a `Source` by using the `join` or `recursiveJoin` method. The match occurs between the base `Source` and the joined `Source`.

The matching of an input acts as a filter so that the `Source` derived by the join operation has only the elements of the base `Source` whose values are related to those of the elements of the joined `Source`. The rules related to matching a `Source` with an input are described in "[Matching a Source with an Input](#) (page 5-13)". That topic has examples that produce derived `Source` objects that are the result of the matching of an input.

A `Source` can have from zero to many inputs. You can get all of the inputs of a `Source` by calling the `getInputs` method.

Some primary `Source` objects have inputs. You can derive a `Source` that has an input by using some methods of the `Source` class.

#### 5.4.3.1 Primary Source Objects with Inputs

The primary `Source` objects for the `MdmDimensionedObject` subclasses `MdmAttribute` and `MdmMeasure` have inputs. The primary `Source` for an `MdmAttribute` has one input. The primary `Source` for an `MdmMeasure` has one or more inputs.

The inputs of an `MdmAttribute` or an `MdmMeasure` are the `Source` objects for the `MdmPrimaryDimension` objects that dimension the attribute or measure. To get the value of an attribute or a measure, you must join the attribute or measure with a `Source` that contains the related dimension members. The join operation matches the input of the attribute or measure with the `Source` that contains the dimension members. [Example 5-7](#) (page 5-14) matches the input of an attribute with the dimension of that attribute. [Example 5-8](#) (page 5-15) matches the inputs of a measure with the dimensions of that measure.

#### 5.4.3.2 Deriving a Source with an Input

Some `Source` methods always return a `Source` that has an input. The `Source` returned by the `extract`, `position`, or `value` method has the base `Source` as an input. You can use these methods to produce a `Source` whose elements are derived, or filtered, from the elements of another `Source`.

The `value` method returns a `Source` that has the elements of the base `Source` and has the base `Source` as an input. You typically use the `Source` returned by the `value` method as the base or joined `Source` of a `join` method, or sometimes as the comparison `Source`. Several examples in this chapter and in [Making Queries Using Source Methods](#) (page 6-1) use the `value` method.

The `position` method returns a `Source` that has the position of each element of the base `Source` and that has the base `Source` as an input. For an example of using the `position` method, see [Example 6-4](#) (page 6-7).

You use the `extract` method when elements of the `Source` objects that you want to join have `Source` objects as values. For examples of using the `extract` method, see [Example 5-12](#) (page 5-18), [Example 6-8](#) (page 6-14), [Example 6-13](#) (page 6-22), and [Example 6-14](#) (page 6-22).

### 5.4.3.3 Type of Inputs

The input of a `Source` derived by the `position` or `value` method, and an input intrinsic to an `MdmDimensionedObject`, are regular inputs. A regular input relates the elements of the `Source` with the input to the elements of the `Source` that matches with the input. You can get the regular inputs by calling the `getRegularInputs` method.

The input of a `Source` returned by the `extract` method is an extraction input. You can get the extraction inputs by calling the `getExtractionInputs` method.

## 5.4.4 Matching a Source with an Input

In a join operation, the matching of a `Source` with an input occurs only between the base `Source` and the joined `Source`. A `Source` matches with an input if one of the following conditions is true.

1. The `Source` is the same object as the input or it is a subtype of the input.
2. The `Source` has an output that is the same object as the input or the output is a subtype of the input.

The join operation looks for the conditions in the order shown in the preceding list. It searches the list of outputs of the `Source` recursively, including any outputs of an output, looking for a match with the input. The search ends with the first matching `Source`. An input can match with only one `Source`.

When a `Source` with an input is joined to a `Source` that matches with the input, the derived `Source` returned by the `join` method has the elements of the base that are related to the elements specified by the parameters of the method. The derived `Source` does not have the input.

Matching a `Source` with an input does not affect the outputs of the base `Source` or the joined `Source`. If a base `Source` has an output that matches with the input of the joined `Source`, then the resulting `Source` does not have the input but it does have the output. If the base `Source` or the joined `Source` in a join operation has an input that is not matched in the operation, then the unmatched input is an input of the resulting `Source`.

The comparison `Source` of a `join` method does not participate in the input matching. If the comparison `Source` has an input, then that input is not matched and the `Source` returned by the `join` method has that same input.

The examples in the following topics demonstrate matching a `Source` with an input.

- [Matching the Input of the Source for an MdmAttribute](#) (page 5-14)
- [Matching the Inputs of a Measure](#) (page 5-14)
- [Using the value Method to Derive a Source with an Input](#) (page 5-15)

- [Using the value Method to Select Values of a Source](#) (page 5-16)
- [Using the extract Method to Combine Elements of Source Objects](#) (page 5-18)

#### 5.4.4.1 Matching the Input of the Source for an MdmAttribute

**Example 5-7** (page 5-14) demonstrates the joining of the Source for an `MdmBaseAttribute` to the Source for an `MdmPrimaryDimension`. The example gets the local value attribute from the `MdmPrimaryDimension` for the `CHANNEL_AWJ` dimension. The Source for the attribute, `locValAttr`, has the Source for the `MdmPrimaryDimension` as an input.

In the example, `locValAttr` is the base Source of the join operation and `chanDim` is the joined Source. Because `chanDim` is an instance of the Source for the `MdmPrimaryDimension` for the `CHANNEL_AWJ` dimension, `chanDim` matches with the input of `locValAttr`. The result of the join is `dimMembersWithLocalValue`, which has `chanDim` as an output and does not have any inputs.

The `locValAttr` Source has four elements because each of the four members of the `CHANNEL_AWJ` dimension has a different local value. The Source derived by the join operation, `dimMembersWithLocalValue`, has four elements. The value of each element is the dimension member and the related attribute value. The dimension member is a value from the output and the attribute value is from the base.

**Example 5-7** (page 5-14) demonstrates matching the input of a base Source with the joined Source. In the example, `mdmDBSchema` is the `MdmDatabaseSchema` for the GLOBAL schema.

A Cursor for the `dimMembersWithLocalValue` Source has the values shown in the following table. The output values are the unique dimension member values derived from the joined Source, `chanDim`. The base values are derived from the base Source, `locValAttr`. The table has headings added.

Output Values	Base Values
<code>CHANNEL_PRIMARY::TOTAL_CHANNEL::TOTAL</code>	TOTAL
<code>CHANNEL_PRIMARY::CHANNEL::CAT</code>	CAT
<code>CHANNEL_PRIMARY::CHANNEL::DIR</code>	DIR
<code>CHANNEL_PRIMARY::CHANNEL::INT</code>	INT

#### **Example 5-7** Getting an Attribute for a Dimension Member

```
MdmStandardDimension mdmChanDim =
    mdmDBSchema.findOrCreateStandardDimension("CHANNEL_AWJ");
Source chanDim = mdmChanDim.getSource();
Source locValAttr = mdmChanDim.getLocalValueAttribute().getSource();
Source dimMembersWithLocalValue = locValAttr.join(chanDim);
```

#### 5.4.4.2 Matching the Inputs of a Measure

**Example 5-8** (page 5-15) demonstrates getting values from a measure. The example gets the `MdmCube` that contains the `UNIT_PRICE` measure and gets the `MdmBaseMeasure` for the measure from that cube. The cube, and the measures of the cube, are dimensioned by the `PRODUCT_AWJ` and `TIME_AWJ` dimensions. The example gets the `MdmPrimaryDimension` objects for those dimensions and gets the Source objects for those metadata objects.

The Source for the measure, `unitPrice`, has the Source objects for the two `MdmPrimaryDimension` objects as inputs. The example joins the Source for the measure with the Source objects for the dimensions. The join operations match the inputs of the measure with the Source objects for the dimensions.



The example first joins the Source for the PRODUCT\_AWJ dimension to the Source for the measure. That `unitPrice.join(prodDim)` operation derives a Source that has base values from `unitPrice` and has `prodDim` as an output. It also has the Source for the TIME\_AWJ dimension as an input. The next join operation joins the Source derived by `unitPrice.join(prodDim)` with `timeDim`, the Source for the TIME\_AWJ dimension. That join operation matches the input of the Source derived by `unitPrice.join(prodDim)` with `timeDim`.

The Source derived by the second join operation is `pricesByProductAndTime`. That Source has no inputs and has the Source objects for the PRODUCT\_AWJ and TIME\_AWJ dimensions as outputs. A Cursor for `pricesByProductAndTime` contains the price of each product value for every time value.

The example finally calls the `count` method of `pricesByProductAndTime`. That method returns the NumberSource `numPricesByProductAndTime`, which contains the number of elements of the `pricesByProductAndTime` Source. A Cursor for the `numPricesByProductAndTime` Source contains the value 4998, which is the number of measure values for the product and time tuples.

To produce a Source that contains only the measure values for certain products and times, you need to join the Source for the measure with Source objects that specify the dimension values that you want. You can produce such a selection by using methods of the primary Source for the dimension. One means of producing a Source that represents a selection of values of a Source is to use the `value` method.

#### **Example 5-8 Getting Measure Values**

This example demonstrates matching the inputs of the base Source with the joined Source. In the example, `mdmDBSchema` is the `MdmDatabaseSchema` for the GLOBAL schema.

```
MdmCube mdmPriceCube =
    mdmDBSchema.findOrCreateCube("PRICE_CUBE_AWJ");
MdmBaseMeasure mdmUnitPrice =
    mdmPriceCube.findOrCreateBaseMeasure("UNIT_PRICE");
MdmStandardDimension mdmProdDim =
    mdmDBSchema.findOrCreateStandardDimension("PRODUCT_AWJ");
MdmTimeDimension mdmTimeDim =
    mdmDBSchema.findOrCreateTimeDimension("TIME_AWJ");

Source prodDim = mdmProdDim.getSource();
Source timeDim = mdmTimeDim.getSource();
Source unitPrice = mdmUnitPrice.getSource();

Source pricesByProductAndTime = unitPrice.join(prodDim).join(timeDim);
NumberSource numPricesByProductAndTime = pricesByProductAndTime.count();
```

#### **5.4.4.3 Using the value Method to Derive a Source with an Input**

##### **Example 5-9 Using the value Method to Relate a Source to Itself**

In this example, the `lettersValue` Source is returned by the `letters.value()` method. The `lettersValue` Source has `letters` as an input. The input represents a relation between the values of the Source with the input and the values of the Source that matches with the input.

The join operation has `letters` as the base Source and `lettersValue` as the joined Source. The base Source, `letters`, matches with the input of `lettersValue`, which is also `letters`, because they are the same. The Source produced by the join operation, `lettersByLettersValue` has `lettersValue` as an output. It does not

have an input. Each element of `lettersByLettersValue` has a base value from `letters` and the related value from `lettersValue`.

```
Source letters = dp.createListSource(new String[] {"A", "B", "C"});
Source lettersValue = letters.value();
Source lettersByLettersValue = letters.join(lettersValue);
```

A Cursor for the `lettersByLettersValue` Source has the values shown in the following table. The table has headings added.

Output Values	Base Values
A	A
B	B
C	C

Because `lettersByLettersValue` contains only those values of the base and joined Source objects that are related, the base values of the Cursor for `lettersByLettersValue` Source are the same as the output values. If the base and joined Source objects had been unrelated, as in `letters.join(letters)`, then the Source produced by the join operation would contain the Cartesian product of the base and joined Source objects.

#### 5.4.4.4 Using the value Method to Select Values of a Source

##### **Example 5-10 Using the value Method to Select Elements of a Source**

By using the `value` method, you can derive a Source that is a selection of the elements of another Source. This example selects two elements from the Source for the `PRODUCT_AWJ` dimension from [Example 5-7](#) (page 5-14). This example demonstrates a base Source matching with the input of the joined Source.

```
Source productsToSelect = dp.createListSource(new String[]
    {"PRODUCT_PRIMARY::ITEM::ENVY EXE",
     "PRODUCT_PRIMARY::ITEM::ENVY STD"});
Source selectedProducts = prodDim.join(prodDim.value(),
    productsToSelect,
    Source.COMPARISON_RULE_SELECT,
    false); // Hide the output.
```

A Cursor for the `productsToSelect` Source has the following values.

```
PRODUCT_PRIMARY::ITEM::ENVY EXE
PRODUCT_PRIMARY::ITEM::ENVY STD
```

A Cursor for the `selectedProducts` Source has the following values.

```
PRODUCT_PRIMARY::ITEM::ENVY EXE
PRODUCT_PRIMARY::ITEM::ENVY STD
```

The two Source objects contain the same values. However, the types of the objects are different. The type of the `productsToSelect` Source is the Source for the `FundamentalMetadataObject` for the String data type. The type of the `selectedProducts` Source is `prodDim` because `selectedProducts` is derived from `prodDim`. Therefore, `selectedProducts` is a subtype of `prodDim` and as such it can match with a Source that has the Source for the `PRODUCT_AWJ` dimension as an input, as shown in the next example.

##### **Example 5-11 Using Derived Source Objects to Select Measure Values**

This example selects elements from the Source objects for two dimensions and then gets the measure values for the selected dimension members. The example uses the

same dimensions and measure as in [Example 5-8](#) (page 5-15). In this example, however, the Source objects that match with the inputs of the Source for the measure are not the Source objects for the dimensions. Instead they are subtypes of the Source objects for the dimensions. The subtypes specify selected members of the dimensions. The Source that is derived by joining the measure with the dimensions, `pricesForSelectedProductsAndTimes`, has six elements, which specify only the measure values for the two products for the three time values, instead of the 4998 elements of the `pricesByProductAndTime` Source in [Example 5-8](#) (page 5-15). In this example, `mdmDBSchema` is the `MdmDatabaseSchema` for the GLOBAL schema.

```
// Create lists of product and time dimension members.
Source productsToSelect = dp.createListSource(new String[]
    {"PRODUCT_PRIMARY::ITEM::ENVY EXE",
     "PRODUCT_PRIMARY::ITEM::ENVY STD"});
Source timesToSelect = dp.createListSource(new String[]
    {"CALENDAR_YEAR::MONTH::2000.01",
     "CALENDAR_YEAR::MONTH::2001.01",
     "CALENDAR_YEAR::MONTH::2002.01"});

// Get the PRICE_CUBE_AWJ cube.
MdmCube mdmPriceCube = mdmDBSchema.findOrCreateCube("PRICE_CUBE_AWJ");
// Get the UNIT_PRICE measure from the cube.
MdmBaseMeasure mdmUnitPrice =
    mdmPriceCube.findOrCreateBaseMeasure("UNIT_PRICE");
// Get the PRODUCT_AWJ and TIME_AWJ dimensions.
MdmStandardDimension mdmProdDim =
    mdmDBSchema.findOrCreateStandardDimension("PRODUCT_AWJ");
MdmTimeDimension mdmTimeDim =
    mdmDBSchema.findOrCreateTimeDimension("TIME_AWJ");
// Get the Source objects for the dimensions and the measure.
Source prodDim = mdmProdDim.getSource();
Source timeDim = mdmTimeDim.getSource();
Source unitPrice = mdmUnitPrice.getSource();
// Using the value method, derive Source objects that specify the selected
// dimension members.
Source selectedProducts = prodDim.join(prodDim.value(),
    productsToSelect,
    Source.COMPARISON_RULE_SELECT,
    false);
Source selectedTimes = timeDim.join(timeDim.value(),
    timesToSelect,
    Source.COMPARISON_RULE_SELECT,
    false);

// Derive a Source that specifies the unitPrice values for the selected products
// and times.
Source pricesForSelectedProductsAndTimes = unitPrice.join(selectedProducts)
    .join(selectedTimes);
```

A Cursor for the `pricesForSelectedProductsAndTimes` Source has the values shown in the following table. The table has headings added.

Month	Product	Price
CALENDAR_YEAR::MONTH::2000.01	PRODUCT_PRIMARY::ITEM::ENVY EXE	3358.02
CALENDAR_YEAR::MONTH::2000.01	PRODUCT_PRIMARY::ITEM::ENVY STD	3000.11
CALENDAR_YEAR::MONTH::2001.01	PRODUCT_PRIMARY::ITEM::ENVY EXE	3223.28
CALENDAR_YEAR::MONTH::2001.01	PRODUCT_PRIMARY::ITEM::ENVY STD	2426.07
CALENDAR_YEAR::MONTH::2002.01	PRODUCT_PRIMARY::ITEM::ENVY EXE	3008.95
CALENDAR_YEAR::MONTH::2002.01	PRODUCT_PRIMARY::ITEM::ENVY STD	2140.71

#### 5.4.4.5 Using the extract Method to Combine Elements of Source Objects

The `extract` method derives a `Source` that has the base `Source` as an input. You use the `extract` method when the values of the elements of a `Source` are `Source` objects themselves.

##### **Example 5-12** *Extracting Elements of a Source*

This example uses the `selectValues` method to derive two selections of elements from a `StringSource` for the `PRODUCT_AWJ` dimension. The `selectValues` method is a shortcut for the full `join` signature of the methods in [Example 5-10](#) (page 5-16) and [Example 5-11](#) (page 5-16) that produce the `selectedProducts` and `selectedTimes` `Source` objects.

This example creates a list `Source`, `sourcesToCombine`, that has the two derived `Source` objects as element values. The `sourcesToCombine.extract()` method produces `sourcesToCombineWithAnInput`, which is a `Source` that has `sourcesToCombine` as an input. The `join` operation `sourcesToCombineWithAnInput.joinHidden(sourcesToCombine)` matches the input of `sourcesToCombineWithAnInput` with the joined `sourcesToCombine` and produces `combinedSources`, which has no inputs or outputs. A shortcut for this combining of `Source` elements is the `appendValues` method.

```
MdmStandardDimension mdmProdDim =
    mdmDBSchema.findOrCreateStandardDimension("PRODUCT_AWJ");
StringSource prodDim = (StringSource) mdmProdDim.getSource();
Source productsToSelect = prodDim.selectValues(new String[]
    {"PRODUCT_PRIMARY::ITEM::ENVY ABM",
     "PRODUCT_PRIMARY::ITEM::ENVY EXE",
     "PRODUCT_PRIMARY::ITEM::ENVY STD"});
Source moreProductsToSelect = prodDim.selectValues(new String[]
    {"PRODUCT_PRIMARY::ITEM::SENT FIN",
     "PRODUCT_PRIMARY::ITEM::SENT MM",
     "PRODUCT_PRIMARY::ITEM::SENT STD"});

Source sourcesToCombine =
    dp.createListSource(new Source[] {productsToSelect, moreProductsToSelect});
Source sourcesToCombineWithAnInput = sourcesToCombine.extract();
Source combinedProducts =
    sourcesToCombineWithAnInput.joinHidden(sourcesToCombine);
```

A `Cursor` for the `combinedProducts` `Source` has the following values.

```
PRODUCT_PRIMARY::ITEM::ENVY ABM
PRODUCT_PRIMARY::ITEM::ENVY EXE
PRODUCT_PRIMARY::ITEM::ENVY STD
PRODUCT_PRIMARY::ITEM::SENT FIN
PRODUCT_PRIMARY::ITEM::SENT MM
PRODUCT_PRIMARY::ITEM::SENT STD
```

## 5.5 Describing Parameterized Source Objects

Parameterized `Source` objects provide a way of specifying a query and retrieving different result sets for the query by changing the set of elements specified by the parameterized `Source`. You create a parameterized `Source` with a `createSource` method of the `Parameter`. The `Parameter` supplies the value that the parameterized `Source` specifies.

The example in this topic is a very simple demonstration of using a `Parameter` object. A typical use of a `Parameter` is to specify the page edges of a cube, as shown in [Example 6-9](#) (page 6-15). Another use of a `Parameter` is to fetch from the server only

the set of elements that you currently need. [Example 6-15](#) (page 6-24) demonstrates using `Parameter` objects to fetch different sets of elements.

When you create a `Parameter` object, you supply an initial value for the `Parameter`. You then create the parameterized `Source` using the `Parameter`. You include the parameterized `Source` in specifying a query. You create a `Cursor` for the query. You can change the value of the `Parameter` with the `setValue` method, which changes the set of elements that the query specifies. Using the same `Cursor`, you can then retrieve the new set of values.

This example demonstrates the use of a `Parameter` and a parameterized `Source` to specify a member in a dimension. The example gets the `MdmStandardDimension` for the `PRODUCT_AWJ` dimension and gets the `Source` for the `MdmStandardDimension` cast as a `StringSource`.

The example creates a `StringParameter` object that has a dimension member as the initial value. It then creates a parameterized `Source`, `paramProdSel`, by using the `createSource` method of the `StringParameter`. Next it uses `paramProdSel` as the comparison `Source` in a join operation that selects the dimension member.

The example gets the `Source` for the local value attribute of the dimension. It joins that `Source`, `locValAttr`, with `paramProdSel`. That join operation produces the `dimMemberWithLocalValue` `Source`.

The example creates a `Cursor` for `dimMemberWithLocalValue` and displays the value of the `Cursor`. After resetting the `Cursor` position and changing the value of the `prodParam` `StringParameter`, the example displays the value of the `Cursor` again.

The `dp` object is the `DataProvider`. The `getContext` method gets a `Context11g` object that has a method that commits the current `Transaction` and a method that displays the values of a `Cursor`.

### **Example 5-13 Using a Parameterized Source to Change a Dimension Selection**

```
MdmStandardDimension mdmProdDim =
    mdmDBSchema.findOrCreateStandardDimension("PRODUCT_AWJ");
StringSource prodDim = (StringSource) mdmProdDim.getSource();

StringParameter prodParam =
    new StringParameter(dp, "PRODUCT_PRIMARY::FAMILY::LTPC");
Source prodParamSrc = prodParam.createSource();
Source paramProdSel = prodDim.join(prodDim.value(), prodParamSrc);

Source locValAttr = mdmProdDim.getLocalValueAttribute().getSource();
Source dimMemberWithLocalValue = locValAttr.join(paramProdSel);

// Commit the Transaction.
getContext().commit();

// Create a Cursor for the Source.
CursorManager cursorMgr = dp.createCursorManager(dimMemberWithLocalValue);
Cursor cursor = cursorMgr.createCursor();

// Display the value of the Cursor.
getContext().displayCursor(cursor);

// Change the product parameter value.
prodParam.setValue("PRODUCT_PRIMARY::FAMILY::DTPC");

// Reset the Cursor position to 1
cursor.setPosition(1);
```

```
// Display the value of the Cursor again.  
getContext().displayCursor(cursor);
```

The Cursor for `dimMemberWithLocalValue` displays the following.

```
PRODUCT_PRIMARY::FAMILY::LTPC,LTPC
```

After changing the value of the `StringParameter` and resetting the position of the Cursor, the Cursor for `dimMemberWithLocalValue` displays the following.

```
PRODUCT_PRIMARY::FAMILY::DTPC,DTPC
```

---

## Making Queries Using Source Methods

You create a query by producing a `Source` that specifies the data that you want to retrieve and any operations that you want to perform on that data. To produce the query, you begin with the primary `Source` objects that represent the metadata of the measures and the dimensions and their attributes that you want to query. Typically, you use the methods of the primary `Source` objects to derive a number of other `Source` objects, each of which specifies a part of the query, such as a selection of dimension members or an operation to perform on the data. You then join the `Source` objects that specify the data and the operations that you want. The result is one `Source` that represents the query. You can then retrieve the data by creating a `Cursor` for the `Source`.

This chapter briefly describes the various kinds of `Source` methods, and discusses some of them in greater detail. It also discusses how to make some typical OLAP queries using these methods and provides examples of some of them.

This chapter includes the following topics:

- [Describing the Basic Source Methods](#) (page 6-1)
- [Using the Basic Methods](#) (page 6-2)
- [Using Other Source Methods](#) (page 6-13)

### 6.1 Describing the Basic Source Methods

The `Source` class has many methods that return a derived `Source`. The elements of the derived `Source` result from operations on the base `Source`, which is the `Source` whose method returns the derived `Source`. Only a few methods perform the most basic operations of the `Source` class.

Many other methods of the `Source` class use one or more of the basic methods to perform operations such as selecting elements of the base `Source` by value or by position, or sorting elements. Many of the examples in this chapter and in [Understanding Source Objects](#) (page 5-1), use some of these methods. Other `Source` methods get objects that have information about the `Source`, such as the `getID`, `getInputs`, and `getType` methods, perform comparisons, such as the `ge` and `gt` methods, or convert the values of the `Source` from one data type to another, such as the `toDoubleSource` method.

**Table 6-1** *The Basic Source Methods*

Method	Description
<code>alias</code>	Returns a <code>Source</code> that has the same elements as the base <code>Source</code> , but has the base <code>Source</code> as the type.

**Table 6-1 (Cont.) The Basic Source Methods**

Method	Description
<code>distinct</code>	Returns a <code>Source</code> that has the same elements as the base <code>Source</code> , except that any elements that are duplicated in the base appear only once in the derived <code>Source</code> .
<code>join</code>	Returns a <code>Source</code> that has the elements of the base <code>Source</code> that are specified by the <code>joined</code> , <code>comparison</code> , and <code>comparisonRule</code> parameters of the method call. If the <code>visible</code> parameter is <code>true</code> , then the joined <code>Source</code> is an output of the resulting <code>Source</code> .
<code>position</code>	Returns a <code>Source</code> that has the positions of the elements of the base <code>Source</code> , and that has the base <code>Source</code> as an input.
<code>recursiveJoin</code>	Similar to the <code>join</code> method, except that this method, in the <code>Source</code> that it returns, orders the elements of the <code>Source</code> hierarchically by parent-child relationships.
<code>value</code>	Returns a <code>Source</code> that has the same elements as the base <code>Source</code> , but that has the base <code>Source</code> as an input.

The following topics describe the basic `Source` methods and provide some examples of their use.

- [Using the Basic Methods](#) (page 6-2)
- [Using Other Source Methods](#) (page 6-13)

## 6.2 Using the Basic Methods

The following topics provide examples of using some of the basic methods.

- [Using the alias Method](#) (page 6-2)
- [Using the distinct Method](#) (page 6-4)
- [Using the join Method](#) (page 6-5)
- [Using the position Method](#) (page 6-6)
- [Using the recursiveJoin Method](#) (page 6-7)
- [Using the value Method](#) (page 6-10)

### 6.2.1 Using the alias Method

You use the `alias` method to control the matching of a `Source` to an input. For example, if you want to find out if the measure values specified by a member of a dimension of the measure are greater than the measure values specified by the other members of the same dimension, then you need to match the inputs of the measure twice in the same join operation. To do so, you can derive two `Source` objects that are aliases for the same dimension, make them inputs of two `Source` objects that are derived from the measure, join each derived measure `Source` to the associated aliased dimension `Source` objects, and then compare the results.



[Example 6-1](#) (page 6-3) performs such an operation. It produces a `Source` that specifies whether the number of units sold for each value of the `CHANNEL_AWJ` dimension is greater than the number of units sold for the other values of the `CHANNEL_AWJ` dimension.

The example joins `units`, which is the `Source` for a measure, to `Source` objects that are selections of single values of three of the dimensions of the measure to produce `unitsSel`. The `unitsSel` `Source` specifies the `units` elements for the dimension values that are specified by the `timeSel`, `custSel`, and `prodSel` objects, which are outputs of `unitsSel`. The `unitsSel` `Source` has the `Source` for `CHANNEL_AWJ` dimension as an input.

The `timeSel`, `custSel`, and `prodSel` `Source` objects specify single values from hierarchies of the `TIME_AWJ`, `CUSTOMER_AWJ`, and `PRODUCT_AWJ` dimensions, respectively. The `timeSel` value is `CALENDAR_YEAR::MONTH::2001.01`, which identifies the month January, 2001, the `custSel` value is `SHIPMENTS::SHIP_TO::BUSN_WRLD_SJ`, which identifies the Business World San Jose customer, and the `prodSel` value is `PRODUCT_PRIMARY::ITEM::ENVY_ABM`, which identifies the Envoy Ambassador portable PC.

The example next creates two aliases, `chanAlias1` and `chanAlias2`, for `chanHier`, which is the `Source` for the `CHANNEL_PRIMARY` hierarchy of the `CHANNEL_AWJ` dimension. It then produces `unitsSel1` by joining `unitsSel` with the `Source` returned by `chanAlias1.value()`. The `unitsSel1` `Source` has the elements and outputs of `unitsSel` and it has `chanAlias1` as an input. Similarly, the example produces `unitsSel2`, which has `chanAlias2` as an input.

The example uses the `gt` method of `unitsSel1`, which determines whether the values of `unitsSel1` are greater than the values of `unitsSel2`. The final join operations match `chanAlias1` with the input of `unitsSel1` and match `chanAlias2` with the input of `unitsSel2`.

#### **Example 6-1 Controlling Input-with-Source Matching with the alias Method**

```
Source unitsSel = units.join(timeSel).join(custSel).join(prodSel);
Source chanAlias1 = chanHier.alias();
Source chanAlias2 = chanHier.alias();
NumberSource unitsSel1 = (NumberSource)
    unitsSel.join(chanAlias1.value());
NumberSource unitsSel2 = (NumberSource)
    unitsSel.join(chanAlias2.value());
Source result = unitsSel1.gt(unitsSel2)
    .join(chanAlias1) // Output 2, column
    .join(chanAlias2); // Output 1, row;
```

The `result` `Source` specifies the query, "Are the units sold values of `unitsSel1` for the channel values of `chanAlias1` greater than the units sold values of `unitsSel2` for the channel values of `chanAlias2`?" Because `result` is produced by the joining of `chanAlias2` to the `Source` returned by `unitsSel1.gt(unitsSel2).join(chanAlias1)`, `chanAlias2` is the first output of `result`, and `chanAlias1` is the second output of `result`.

A `Cursor` for the `result` `Source` has as values the boolean values that answer the query. The values of the first output of the `Cursor` are the channel values specified by `chanAlias2` and the values of the second output are the channel values specified by `chanAlias1`.

The following is a display of the values of the `Cursor` formatted as a crosstab with headings added. The column edge values are the values from `chanAlias1`, and the row edge values are the values from `chanAlias2`. The values of the crosstab cells are

the boolean values that indicate whether the units sold value for the column channel value is greater than the units sold value for the row channel value. For example, the crosstab values in the first column indicate that the units sold value for the column channel value `Total Channel` is not greater than the units sold value for the row `Total Channel` value but it is greater than the units sold value for the `Direct Sales`, `Catalog`, and `Internet` row values.

chanAlias2	----- chanAlias1 -----			
	TotalChannel	Catalog	Direct Sales	Internet
TotalChannel	false	false	false	false
Catalog	true	false	false	false
Direct Sales	true	true	false	false
Internet	true	true	true	false

## 6.2.2 Using the distinct Method

You use the `distinct` method to produce a `Source` that does not have any duplicated values, as shown in [Example 6-2](#) (page 6-4). The example joins two selections of dimension members. Some dimension members exist in both selections. The example uses the `distinct` method to produce a `Source` that contains only unique dimension members, with no duplicated values.

The example gets the `MdmStandardDimension` object for the `CUSTOMER_AWJ` dimension and gets the `MdmLevelHierarchy` object for the `MARKETS` hierarchy of that dimension. It gets the `StringSource` object, `mktHier`, for the `MdmLevelHierarchy`. It then uses the `selectValues` method of `mktHier` to produce two selections of members of the hierarchy, `customersToSelect` and `moreCustomersToSelect`. Two of the members of `customersToSelect` are also present in `moreCustomersToSelect`.

The example uses the `appendValues` method to combine the elements of `customersToSelect` and `moreCustomersToSelect` in the combined `customers` `Source`. Finally, the example uses the `distinct` method of `combinedCustomers`, which returns a `Source`, `distinctCombinedCustomers`, that has only the distinct members of the hierarchy.

### **Example 6-2 Using the distinct Method**

```
MdmStandardDimension mdmCustDim =
    mdmDBSchema.findOrCreateStandardDimension("CUSTOMER_AWJ");
MdmLevelHierarchy mdmMktHier =
    mdmCustDim.findOrCreateLevelHierarchy("MARKETS");
StringSource mktHier = (StringSource)mdmMktHier.getSource();

Source customersToSelect =
    mktHier.selectValues(new String[] { "MARKETS::SHIP_TO::KOSH ENT BOS",
                                        "MARKETS::SHIP_TO::KOSH ENT TOK",
                                        "MARKETS::SHIP_TO::KOSH ENT WAN" });

Source moreCustomersToSelect =
    mktHier.selectValues(new String[] { "MARKETS::SHIP_TO::KOSH ENT BOS",
                                        "MARKETS::SHIP_TO::KOSH ENT TOK",
                                        "MARKETS::SHIP_TO::BUSN WRLD NY",
                                        "MARKETS::SHIP_TO::BUSN WRLD SJ" });

Source combinedCustomers =
    customersToSelect.appendValues(moreCustomersToSelect);

Source distinctCombinedCustomers = combinedCustomers.distinct();
```

A `Cursor` for the `combinedCustomers` `Source` has the following values:

```

MARKETS::SHIP_TO::KOSH ENT BOS
MARKETS::SHIP_TO::KOSH ENT TOK
MARKETS::SHIP_TO::KOSH ENT WAN
MARKETS::SHIP_TO::KOSH ENT BOS
MARKETS::SHIP_TO::KOSH ENT TOK
MARKETS::SHIP_TO::BUSN WRLD NY
MARKETS::SHIP_TO::BUSN WRLD SJ

```

A Cursor for the `distinctCombinedCustomers` Source has the following values:

```

MARKETS::SHIP_TO::KOSH ENT BOS
MARKETS::SHIP_TO::KOSH ENT TOK
MARKETS::SHIP_TO::KOSH ENT WAN
MARKETS::SHIP_TO::BUSN WRLD NY
MARKETS::SHIP_TO::BUSN WRLD SJ

```

## 6.2.3 Using the join Method

As described in [Understanding Source Objects](#) (page 5-1), you use the `join` method to produce a Source that has the elements of the base Source that are determined by the `joined`, `comparison`, and `comparisonRule` parameters of the method. The `visible` parameter determines whether the `joined` parameter Source is an output of the Source produced by the join operation. You also use the `join` method to match a Source with an input of the base or `joined` parameter Source.

Most of the examples in this chapter use one or more signatures of the `join` method, as do many of the examples in [Understanding Source Objects](#) (page 5-1). [Example 6-3](#) (page 6-6) uses the full `join` signature and the simplest `join` signature. In the example, the full `join` signature demonstrates the use of `COMPARISON_RULE_DESCENDING` as the `comparisonRule` parameter.

[Example 6-3](#) (page 6-6) uses the following Source objects.

- `prodSelWithShortDescr`, which is the Source produced by joining the short description attribute of the `PRODUCT_AWJ` dimension with the Source for the `FAMILY` hierarchy level of the `PRODUCT_PRIMARY` hierarchy of the dimension.
- `salesMeasure`, which is the Source for the `SALES` measure of the `UNITS_CUBE_AWJ` cube.
- `timeSelWithShortDescr`, which is the Source produced by joining the short description attribute of the `TIME_AWJ` dimension with the Source for a selected member of the `CALENDAR_YEAR` hierarchy of the dimension.
- `custSelWithShortDescr`, which is the Source produced by joining the short description attribute of the `CUSTOMER_AWJ` dimension with the Source for a selected member of the `SHIPMENTS` hierarchy of the dimension.
- `chanSelWithShortDescr`, which is the Source produced by joining the short description attribute of the `CHANNEL_AWJ` dimension with the Source for a selected member of the `CHANNEL_PRIMARY` hierarchy of the dimension.

The first join operation uses the full signature of the `join` method with `prodSelWithShortDescr` as the base Source, `salesMeasure` as the `joined` Source, the Source for the Number data type as the `comparison` Source, and `COMPARISON_RULE_DESCENDING` as the `comparisonRule`. The Source returned by that join operation has the product family level members and related product short description values as base values and an output that has the sales amounts in descending order.

The next three join operations join the single member selections of the other three dimensions of the measure. The `result` Source specifies the product family level members in descending order of sales amounts for the month of May, 2001 for all customers and all channels.

**Example 6-3 Using `COMPARISON_RULE_DESCENDING`**

```
Source result = prodSelWithShortDescr.join(salesMeasure,
                                           salesMeasure.getDataType(),
                                           Source.COMPARISON_RULE_DESCENDING,
                                           true)
                                           .join(timeSelWithShortDescr)
                                           .join(custSelWithShortDescr)
                                           .join(chanSelWithShortDescr);
```

A Cursor for the `result` Source has the following values, displayed as a table. The table includes only the short value descriptions of the hierarchy members and the sales amount values, and has headings and formatting added.

```
Total Channel
Total Customer
MAY-01
```

Total Sales Amounts	Product Family
-----	-----
3,580,239.72	Desktop PCs
2,508,560.92	Portable PCs
891,807.30	CD/DVD
632,376.84	Modems/Fax
444,444.38	Memory
312,389.39	Accessories
291,510.88	Monitors
222,995.92	Operating Systems
44,479.32	Documentation

## 6.2.4 Using the position Method

You use the `position` method to produce a Source that has the positions of the elements of the base and has the base as an input. [Example 6-4](#) (page 6-7) uses the `position` method in producing a Source that specifies the selection of the first and last members of the levels of a hierarchy of the `TIME_AWJ` dimension.

In the example, `mdmTimeDim` is the `MdmPrimaryDimension` for the `TIME_AWJ` dimension. The example gets the level attribute and the `CALENDAR_YEAR` hierarchy of the dimension. It then gets Source objects for the attribute and the hierarchy.

Next, the example creates an array of Source objects and gets a List of the `MdmHierarchyLevel` components of the hierarchy. It gets the Source object for each level and adds it to the array, and then creates a list Source that has the Source objects for the levels as element values.

The example then produces `levelMembers`, which is a Source that specifies the members of the levels of the hierarchy. Because the `comparison` parameter of the join operation is the Source produced by `levelList.value()`, `levelMembers` has `levelList` as an input. Therefore, `levelMembers` is a Source that returns the members of each level, by level, when the input is matched in a join operation.

The `range` Source specifies a range of elements from the second element to the next to last element of a Source.

The next join operation produces the `firstAndLast` Source. The base of the operation is `levelMembers`. The `joined` parameter is the Source that results from the `levelMembers.position()` method. The comparison parameter is the range Source and the comparison rule is `COMPARISON_RULE_REMOVE`. The value of the `visible` parameter is `true`. The `firstAndLast` Source therefore specifies only the first and last members of the levels because it removes all of the other members of the levels from the selection. The `firstAndLast` Source still has `levelList` as an input.

The final join operation matches the input of `firstAndLast` with `levelList`.

#### **Example 6-4 Selecting the First and Last Time Elements**

```
MdmAttribute mdmTimeLevelAttr = mdmTimeDim.getLevelAttribute();
MdmLevelHierarchy mdmCalHier =
    mdmTimeDim.findOrCreateLevelHierarchy("CALENDAR_YEAR");

Source levelRel = mdmTimeLevelAttr.getSource();
StringSource calHier = (StringSource) mdmCalHier.getSource();

Source[] levelSources = new Source[3];
List levels = mdmCalHier.getHierarchyLevels();
for (int i = 0; i < levelSources.length; i++)
{
    levelSources[i] = ((MdmHierarchyLevel) levels.get(i)).getSource();
}
Source levelList = dp.createListSource(levelSources);
Source levelMembers = calHier.join(levelRel, levelList.value());
Source range = dp.createRangeSource(2, levelMembers.count().minus(1));
Source firstAndLast = levelMembers.join(levelMembers.position(),
                                        range,
                                        Source.COMPARISON_RULE_REMOVE,
                                        true);

Source result = firstAndLast.join(levelList);
```

A Cursor for the `result` Source has the following values, displayed as a table with column headings and formatting added. The left column names the level, the middle column is the position of the member in the level, and the right column is the local value of the member. The `TOTAL_TIME` level has only one member.

Level	Member Position in Level	Member Value
TOTAL_TIME	1	TOTAL
YEAR	1	CY1998
YEAR	10	CY2007
QUARTER	1	CY1998.Q1
QUARTER	40	CY2007.Q4
MONTH	1	1998.01
MONTH	120	2007.12

## 6.2.5 Using the recursiveJoin Method

You use the `recursiveJoin` method to produce a Source that has elements that are ordered hierarchically. You use the `recursiveJoin` method only with the Source for an `MdmHierarchy` or with a subtype of such a Source. The method produces a Source whose elements are ordered hierarchically by the parents and their children in the hierarchy.

Like the `join` method, you use the `recursiveJoin` method to produce a Source that has the elements of the base Source that are determined by the `joined`,

comparison, and `comparisonRule` parameters of the method. The `visible` parameter determines whether the joined `Source` is an output of the `Source` produced by the recursive join operation.

The full `recursiveJoin` method has other parameters that specify the parent attribute of the hierarchy, whether the result should have the parents before or after their children, and how to order the elements of the result if the result includes children but not the parent. The `recursiveJoin` method has several signatures that are shortcuts for the full signature.

[Example 6-5](#) (page 6-8) uses a `recursiveJoin` method that lists the parents first, restricts the parents to the base, and does not add the joined `Source` as an output. The example first sorts the members of the `PRODUCT_PRIMARY` hierarchy of the `PRODUCT_AWJ` dimension by hierarchical levels and then by the value of the package attribute of each member.

In the first `recursiveJoin` method, the `COMPARISON_RULE_ASCENDING` parameter specifies that the members of the `prodHier` hierarchy be in ascending alphabetical order within each level. The `prodParentAttr` object is the `Source` for the parent attribute of the hierarchy.

The `prodPkgAttr` object in the second `recursiveJoin` method is the `Source` for the package attribute of the dimension. Only the members of the `ITEM` level have a related package attribute value. Because the members in the aggregate levels `TOTAL_PRODUCT`, `CLASS`, and `FAMILY`, do not have a related package, the package attribute value for members in those levels is `null`, which appears as `NA` in the results. Some of the `ITEM` level members do not have a related package value, so their values are `NA`, also.

The second `recursiveJoin` method joins the package attribute values to their related hierarchy members and sorts the members hierarchically by level, and then sorts them in ascending alphabetical order in the level by the package attribute value. The `COMPARISON_RULE_ASCENDING_NULLS_FIRST` parameter specifies that members that have a `null` value appear before the other members in the same level. The example then joins the result of the method, `sortedHierAscending`, to the package attribute to produce a `Source` that has the package attribute values as element values and `sortedHierAscending` as an output.

The third `recursiveJoin` method is the same as the second, except that the `COMPARISON_RULE_DESCENDING_NULLS_FIRST` parameter sorts the hierarchy members in descending alphabetical order in the level by package attribute value.

#### **Example 6-5** *Sorting Products Hierarchically by Attribute*

```
Source result1 = prodHier.recursiveJoin(prodDim.value(),
                                       prodHier.getDataType(),
                                       prodParentAttr,
                                       Source.COMPARISON_RULE_ASCENDING);

Source sortedHierAscending =
    prodHier.recursiveJoin(prodPkgAttr,
                          prodPkgAttr.getDataType(),
                          prodParentAttr,
                          Source.COMPARISON_RULE_ASCENDING_NULLS_FIRST);
Source result2 = prodPkgAttr.join(sortedHierAscending);

Source sortedHierDescending =
    prodHier.recursiveJoin(prodPkgAttr,
                          prodPkgAttr.getDataType(),
                          prodParentAttr,
```

```

Source.COMPARISON_RULE_DESCENDING_NULLS_FIRST);
Source result3 = prodPkgAttr.join(sortedHierDescending);

```

A Cursor for the `result1` Source has the following values, displayed with a heading added. The list contains only the first seventeen values of the Cursor.

```

Product Primary Hierarchy Value
-----
PRODUCT_PRIMARY::TOTAL_PRODUCT::TOTAL
PRODUCT_PRIMARY::CLASS::HRD
PRODUCT_PRIMARY::FAMILY::DISK
PRODUCT_PRIMARY::ITEM::EXT CD ROM
PRODUCT_PRIMARY::ITEM::EXT DVD
PRODUCT_PRIMARY::ITEM::INT 8X DVD
PRODUCT_PRIMARY::ITEM::INT CD ROM
PRODUCT_PRIMARY::ITEM::INT CD USB
PRODUCT_PRIMARY::ITEM::INT RW DVD
PRODUCT_PRIMARY::FAMILY::DTPC
PRODUCT_PRIMARY::ITEM::SENT FIN
PRODUCT_PRIMARY::ITEM::SENT MM
PRODUCT_PRIMARY::ITEM::SENT STD
PRODUCT_PRIMARY::FAMILY::LTPC
PRODUCT_PRIMARY::ITEM::ENVY ABM
PRODUCT_PRIMARY::ITEM::ENVY EXE
PRODUCT_PRIMARY::ITEM::ENVY STD
...

```

A Cursor for the `result2` Source has the following values, displayed as a table with headings added. The table contains only the first seventeen values of the Cursor. The left column has the member values of the hierarchy and the right column has the package attribute value for the member.

The ITEM level members that have a null value appear first, and then the other level members appear in ascending order of package value. Since the data type of the package attribute is String, the package values are in ascending alphabetical order.

Product Primary Hierarchy Value	Package Attribute Value
PRODUCT_PRIMARY::TOTAL_PRODUCT::TOTAL	NA
PRODUCT_PRIMARY::CLASS::HRD	NA
PRODUCT_PRIMARY::FAMILY::DISK	NA
PRODUCT_PRIMARY::ITEM::EXT CD ROM	NA
PRODUCT_PRIMARY::ITEM::INT 8X DVD	NA
PRODUCT_PRIMARY::ITEM::INT CD USB	NA
PRODUCT_PRIMARY::ITEM::EXT DVD	Executive
PRODUCT_PRIMARY::ITEM::INT CD ROM	Laptop Value Pack
PRODUCT_PRIMARY::ITEM::INT RW DVD	Multimedia
PRODUCT_PRIMARY::FAMILY::DTPC	NA
PRODUCT_PRIMARY::ITEM::SENT FIN	NA
PRODUCT_PRIMARY::ITEM::SENT STD	NA
PRODUCT_PRIMARY::ITEM::SENT MM	Multimedia
PRODUCT_PRIMARY::FAMILY::LTPC	NA
PRODUCT_PRIMARY::ITEM::ENVY ABM	NA
PRODUCT_PRIMARY::ITEM::ENVY EXE	Executive
PRODUCT_PRIMARY::ITEM::ENVY STD	Laptop Value Pack
...	

A Cursor for the `result3` Source has the following values, displayed as a table with headings added. This time the members are in descending order, alphabetically by package attribute value.

Product Primary Hierarchy Value	Package Attribute Value
PRODUCT_PRIMARY::TOTAL_PRODUCT::TOTAL	NA
PRODUCT_PRIMARY::CLASS::HRD	NA
PRODUCT_PRIMARY::FAMILY::DISK	NA
PRODUCT_PRIMARY::ITEM::EXT CD ROM	NA
PRODUCT_PRIMARY::ITEM::INT 8X DVD	NA
PRODUCT_PRIMARY::ITEM::INT CD USB	NA
PRODUCT_PRIMARY::ITEM::INT RW DVD	Multimedia
PRODUCT_PRIMARY::ITEM::INT CD ROM	Laptop Value Pack
PRODUCT_PRIMARY::ITEM::EXT DVD	Executive
PRODUCT_PRIMARY::FAMILY::DTPC	NA
PRODUCT_PRIMARY::ITEM::SENT FIN	NA
PRODUCT_PRIMARY::ITEM::SENT STD	NA
PRODUCT_PRIMARY::ITEM::SENT MM	Multimedia
PRODUCT_PRIMARY::FAMILY::LTPC	NA
PRODUCT_PRIMARY::ITEM::ENVY ABM	NA
PRODUCT_PRIMARY::ITEM::ENVY STD	Laptop Value Pack
PRODUCT_PRIMARY::ITEM::ENVY EXE	Executive
...	

## 6.2.6 Using the value Method

As described in "[Deriving a Source with an Input](#) (page 5-12)", you use the value method to create a `Source` that has itself as an input. That relationship enables you to select a subset of elements of the `Source`. You can also use the value method to reverse a relation.

The following topics have examples of these operations.

- [Selecting Elements of a Source](#) (page 6-10)
- [Reversing a Relation](#) (page 6-11)

### 6.2.6.1 Selecting Elements of a Source

[Example 5-11](#) (page 5-16) and [Example 6-6](#) (page 6-11) demonstrate the selection of a subset of the elements of a `Source`. In [Example 6-6](#) (page 6-11), `shipHier` is a `Source` for the SHIPMENTS hierarchy of the CUSTOMER\_AWJ dimension. The `selectValues` method of `shipHier` produces `custSel`, which is a selection of some of the elements of `shipHier`. The `selectValues` method of `custSel` produces `custSel2`, which is a subset of that selection.

The first `join` method has `custSel` as the base and as the joined `Source`. It has `custSel2` as the comparison `Source`. The elements of the resulting `Source`, `result1`, are the Cartesian product of the base and joined `Source` objects that are specified by the comparison `Source`. The `result1` `Source` has one set of the elements of `custSel` for each element of `custSel` that is in the comparison `Source`. The true value of the `visible` parameter causes the joined `Source` to be an output of `result1`.

The second `join` method also has `custSel` as the base and `custSel2` as the comparison `Source`, but it has the `Source` returned by the `custSel.value()` method as the joined `Source`. Because `custSel` is an input of the joined `Source`, the base `Source` matches with that input. That input relationship causes the resulting `Source`, `result2`, to have only those elements of `custSel` that are also in the comparison `Source`.



**Example 6-6 Selecting a Subset of the Elements of a Source**

```
StringSource custSel = shipHier.selectValues(new String[]
    {"SHIPMENTS::SHIP_TO::COMP WHSE SIN",
     "SHIPMENTS::SHIP_TO::COMP WHSE LON",
     "SHIPMENTS::SHIP_TO::COMP WHSE SJ",
     "SHIPMENTS::SHIP_TO::COMP WHSE ATL"});

Source custSel2 = custSel.selectValues(new String[]
    {"SHIPMENTS::SHIP_TO::COMP WHSE SIN",
     "SHIPMENTS::SHIP_TO::COMP WHSE SJ"});

Source result1 = custSel.join(custSel, custSel2, true);

Source result2 = custSel.join(custSel.value(), custSel2, true);
```

A `Cursor` for `result1` has the values shown in the following table. The table has formatting and headings that are not in the `Cursor`. The left column has the values of the elements of the output of the `Cursor`. The right column has the base values of the `Cursor`.

Output Value	result1 Value
SHIPMENTS::SHIP_TO::COMP WHSE SJ	SHIPMENTS::SHIP_TO::COMP WHSE ATL
SHIPMENTS::SHIP_TO::COMP WHSE SJ	SHIPMENTS::SHIP_TO::COMP WHSE SJ
SHIPMENTS::SHIP_TO::COMP WHSE SJ	SHIPMENTS::SHIP_TO::COMP WHSE SIN
SHIPMENTS::SHIP_TO::COMP WHSE SJ	SHIPMENTS::SHIP_TO::COMP WHSE LON
SHIPMENTS::SHIP_TO::COMP WHSE SIN	SHIPMENTS::SHIP_TO::COMP WHSE ATL
SHIPMENTS::SHIP_TO::COMP WHSE SIN	SHIPMENTS::SHIP_TO::COMP WHSE SJ
SHIPMENTS::SHIP_TO::COMP WHSE SIN	SHIPMENTS::SHIP_TO::COMP WHSE SIN
SHIPMENTS::SHIP_TO::COMP WHSE SIN	SHIPMENTS::SHIP_TO::COMP WHSE LON

A `Cursor` for `result2` has the following values, displayed as a table with headings added. The left column has the values of the elements of the output of the `Cursor`. The right column has the base values of the `Cursor`.

Output Value	result2 Value
SHIPMENTS::SHIP_TO::COMP WHSE SJ	SHIPMENTS::SHIP_TO::COMP WHSE SJ
SHIPMENTS::SHIP_TO::COMP WHSE SIN	SHIPMENTS::SHIP_TO::COMP WHSE SIN

**6.2.6.2 Reversing a Relation**

Another use of the `value` method is to reverse a relation, as shown in [Example 6-7](#) (page 6-12). The example reverses the ancestor attribute relation of the `CUSTOMER_AWJ` dimension to produce a `Source`, `marketsDescendants`, that represents a descendants relation. The `marketsDescendants` `Source` has as an input the `Source` for the `MARKETS` hierarchy of the dimension. When you join `marketsDescendants` with a `Source` that matches with that input, you get a `Source` that specifies the descendants of the participating members of the hierarchy.

Another example of reversing a relation is [Example 6-10](#) (page 6-18). It uses the `value` method in reversing the parent attribute to get the children of a parent.

[Example 6-7](#) (page 6-12) first gets the `MdmStandardDimension` object for the `CUSTOMER_AWJ` dimension and the `MdmLevelHierarchy` object for the `MARKETS` hierarchy of that dimension. It gets the `Source` for the hierarchy.

The example next gets the ancestors attribute of the dimension and the `Source` for it. The ancestors attribute relates each dimension member to the ancestors of that member.

To produce a `Source` that represents the descendants of each member of the dimension, the example reverses the ancestor relation by joining the `Source` for the hierarchy, `mktHier`, with the ancestors attribute, `ancestorsAttr`. The join operation uses `mktHier.value()` as the comparison `Source`, so that the `Source` returned by the join operation, `marketsDescendants`, has `mktHier` as an input. The `marketsDescendants` `Source` specifies, for each element of `ancestorsAttr`, the elements of `mktHier` that have the `ancestorsAttr` element as their ancestor. Because it has `mktHier` as an input, the `marketsDescendants` `Source` functions in the same way as an attribute that represents the descendants relationship for the hierarchy.

The example demonstrates this when it joins `mktHier` to `marketsDescendants` in the following line.

```
Source selValDescendants = marketsDescendants.join(mktHier, selVal);
```

In the join operation, the joined `Source`, `mktHier`, matches with the input of `marketsDescendants`. The comparison `Source` is `selVal`, which specifies a single member of the hierarchy. The join operation returns `selValDescendants`, which specifies the elements of `marketsDescendants` that are the descendants of the `selVal` member. The result also includes the ancestor member itself. The `mktHier` `Source` is not an output of `selValDescendants` because the signature of the join method used derives a `Source` that does not have the joined `Source` as an output.

The example next uses the full signature of the join method to produce `selValDescendantsOnly`, which contains only the descendants and not the ancestor value. To remove the ancestor value, the example again uses the `value` method, this time to return a `Source` that is the joined parameter of the join operation that returns `selValDescendantsOnly`. The comparison `Source` is `selVal`, and the comparison rule is `COMPARISON_RULE_REMOVE`.

Finally, the example uses the `removeValue` method to produce `selValDescendantsOnly2`, which is the same as `selValDescendantsOnly`. This simply demonstrates that the `removeValue` method is a shortcut for the join operation that returned `selValDescendantsOnly`.

### **Example 6-7 Using the value Method to Reverse a Relation**

```
MdmStandardDimension mdmCustDim =
    mdmDBSchema.findOrCreateStandardDimension("CUSTOMER_AWJ");
MdmLevelHierarchy mdmMktHier =
    mdmCustDim.findOrCreateLevelHierarchy("MARKETS");
StringSource mktHier = (StringSource)mdmMktHier.getSource();
MdmAttribute mdmAncestorsAttr = mdmCustDim.getAncestorsAttribute();
Source ancestorsAttr = mdmAncestorsAttr.getSource();

// Reverse the ancestors relation to get the descendants relation.
Source marketsDescendants = mktHier.join(ancestorsAttr, mktHier.value());

Source selVal = mktHier.selectValue("MARKETS::ACCOUNT::BUSN WRLD");

// Select the descendants of the specified hierarchy member.
StringSource selValDescendants =
    (StringSource)marketsDescendants.join(mktHier, selVal);

// Remove the ancestor value so that only the descendants remain.
Source selValDescendantsOnly =
    selValDescendants.join(selValDescendants.value(),
        selVal,
        Source.COMPARISON_RULE_REMOVE),
```

```

false;

// Produce the same result using the removeValue method.
Source selValDescendantsOnly2 =
  selValDescendants.removeValue("MARKETS::ACCOUNT::BUSN WRLD");

```

A Cursor for `selValDescendants` has the following values.

```

MARKETS::ACCOUNT::BUSN WRLD
MARKETS::SHIP_TO::BUSN WRLD HAM
MARKETS::SHIP_TO::BUSN WRLD NAN
MARKETS::SHIP_TO::BUSN WRLD NY
MARKETS::SHIP_TO::BUSN WRLD SJ

```

A Cursor for `selValDescendantsOnly` has the following values.

```

MARKETS::SHIP_TO::BUSN WRLD HAM
MARKETS::SHIP_TO::BUSN WRLD NAN
MARKETS::SHIP_TO::BUSN WRLD NY
MARKETS::SHIP_TO::BUSN WRLD SJ

```

A Cursor for `selValDescendantsOnly2` has the following values.

```

MARKETS::SHIP_TO::BUSN WRLD HAM
MARKETS::SHIP_TO::BUSN WRLD NAN
MARKETS::SHIP_TO::BUSN WRLD NY
MARKETS::SHIP_TO::BUSN WRLD SJ

```

## 6.3 Using Other Source Methods

Along with the methods that are various signatures of the basic methods, the `Source` class has many other methods that use combinations of the basic methods. Some methods perform selections based on a single position, such as the `at` and `offset` methods. Others operate on a range of positions, such as the `interval` method. Some perform comparisons, such as `eq` and `gt`, select one or more elements, such as `selectValue` or `removeValue`, or sort elements, such as `sortAscending` or `sortDescendingHierarchically`.

The subclasses of `Source` each have other specialized methods, also. For example, the `NumberSource` class has many methods that perform mathematical functions such as `abs`, `div`, and `cos`, and methods that perform aggregations, such as `average` and `total`.

The following topics have examples that demonstrate the use of some of the `Source` methods. Some of the examples are tasks that an OLAP application typically performs.

- [Using the extract Method](#) (page 6-14)
- [Creating a Cube and Pivoting Edges](#) (page 6-14)
- [Drilling Up and Down in a Hierarchy](#) (page 6-17)
- [Sorting Hierarchically by Measure Values](#) (page 6-19)
- [Using NumberSource Methods To Compute the Share of Units Sold](#) (page 6-20)
- [Selecting Based on Time Series Operations](#) (page 6-21)
- [Selecting a Set of Elements Using Parameterized Source Objects](#) (page 6-23)

### 6.3.1 Using the extract Method

You use the `extract` method to extract the values of a `Source` that is the value of an element of another `Source`. If the elements of a `Source` have element values that are not `Source` objects, then the `extract` method operates like the `value` method.

**Example 6-8** (page 6-14) uses the `extract` method to get the values of the `NumberSource` objects that are themselves the values of the elements of the list `Source` `measDim`. Each of the `NumberSource` objects represents a measure.

The example selects elements from `StringSource` objects for the hierarchies of the dimensions of the `UNITS_CUBE_AWJ` cube. The `cost`, `units`, and `sales` objects are `NumberSource` objects for the `COST`, `UNITS`, and `SALES` measures of the cube.

Next, the example creates `measDim`, which is a list `Source` that has the three `NumberSource` objects as element values. It then uses the `extract` method to get the values of the `NumberSource` objects. The resulting unnamed `Source` has `measDim` as an extraction input. The first join operation has `measDim.extract()` as the base `Source`. The input of the base `Source` matches with `measDim`, which is the joined parameter. The example then matches the other inputs of the measures by joining the dimension selections to produce the `result` `Source`.

#### **Example 6-8** Using the extract Method

```
Source prodSel = prodHier.selectValues(new String[]
    { "PRODUCT_PRIMARY::ITEM::ENVY STD",
      "PRODUCT_PRIMARY::ITEM::ENVY EXE",
      "PRODUCT_PRIMARY::ITEM::ENVY ABM" });

Source chanSel = chanHier.selectValue("CHANNEL_PRIMARY::CHANNEL::DIR");
Source timeSel = timeHier.selectValue("CALENDAR_YEAR::MONTH::2001.05");
Source custSel = custHier.selectValue("SHIPMENTS::TOTAL_CUSTOMER::TOTAL");

Source measDim = dp.createListSource(new Source[] {cost, units, sales});

Source result = measDim.extract().join(measDim) // column
    .join(prodSel) // row
    .join(timeSel) // page
    .join(chanSel) // page
    .join(custSel); // page
```

The following crosstab displays the values of a `Cursor` for the `result` `Source`, with headings and formatting added.

```
SHIPMENTS::TOTAL_CUSTOMER::TOTAL
CHANNEL_PRIMARY::CHANNEL::DIR
CALENDAR_YEAR::MONTH::2001.05
```

ITEM	COST	UNITS SOLD	SALES AMOUNT
ENVY ABM	73,316.10	26	77,825.54
ENVY EXE	111,588.30	37	116,470.45
ENVY STD	92,692.47	39	93,429.57

### 6.3.2 Creating a Cube and Pivoting Edges

One typical OLAP operation is the creation of a cube, which is a multi-dimensional array of data. The data of the cube is specified by the elements of the column, row, and page edges of the cube. The data of the cube can be data from a measure that is specified by the members of the dimensions of the measure. The cube data can also be

dimension members that are specified by some calculation of the measure data, such as products that have unit sales quantities greater than a specified amount.

Most of the examples in this topic create cubes. [Example 6-9](#) (page 6-15) creates a cube that has the quantity of units sold as the data of the cube. The column edge values are initially from a channel dimension hierarchy, the row edge values are from a time dimension hierarchy, and the page edge values are from hierarchies for product and customer dimensions. The product and customer member values on the page edge are represented by parameterized `Source` objects.

The example joins the selections of the hierarchy members to the short value description attributes for the dimensions so that the results include the attribute values. The example then joins the `Source` objects derived from the hierarchies to the `Source` for the measure to produce the cube query. It commits the current `Transaction`, and then creates a `Cursor` for the query and displays the values.

After displaying the values of the `Cursor`, the example changes the value of the `Parameter` for the parameterized `Source` for the customer selection, thereby retrieving a different result set using the same `Cursor` in the same `Transaction`. The example resets the position of the `Cursor`, and displays the values of the `Cursor` again.

The example then pivots the column and row edges so that the column values are time members and the row values are channel members. It commits the `Transaction`, creates another `Cursor` for the query, and displays the values. It then changes the value of each `Parameter` object and displays the values of the `Cursor` again.

The `dp` object is the `DataProvider`. The `getContext` method gets a `Context11g` object that has a method that displays the values of the `Cursor` in a crosstab format.

### **Example 6-9 Creating a Cube and Pivoting the Edges**

```
// Create Parameter objects with values from the hierarchies
// of the CUSTOMER_AWJ and PRODUCT_AWJ dimensions.
StringParameter custParam =
    new StringParameter(dp, "SHIPMENTS::REGION::EMEA");
StringParameter prodParam =
    new StringParameter(dp, "PRODUCT_PRIMARY::FAMILY::LTPC");

// Create parameterized Source objects using the Parameter objects.
Source custParamSrc = custParam.createSource();
Source prodParamSrc = prodParam.createSource();

// Select single values from the hierarchies, using the Parameter
// objects as the comparisons in the join operations.
Source paramCustSel = custHier.join(custHier.value(), custParamSrc);
Source paramProdSel = prodHier.join(prodHier.value(), prodParamSrc);

// Select members from the other dimensions of the measure.
Source timeSel =
    timeHier.selectValues(new String[] { "CALENDAR_YEAR::YEAR::CY1999"
                                          "CALENDAR_YEAR::YEAR::CY2000",
                                          "CALENDAR_YEAR::YEAR::CY2001" });
Source chanSel =
    chanHier.selectValues(new String[] { "CHANNEL_PRIMARY::CHANNEL::DIR",
                                          "CHANNEL_PRIMARY::CHANNEL::CAT",
                                          "CHANNEL_PRIMARY::CHANNEL::INT" });

// Join the hierarchy selections to the short description attributes
// for the dimensions.
Source columnEdge = chanSel.join(chanShortDesc);
```

```
Source rowEdge = timeSel.join(timeShortDescr);
Source page1 = paramProdSel.join(prodShortDescr);
Source page2 = paramCustSel.join(custShortDescr);

// Join the dimension selections to the measure.
Source cube = units.join(columnEdge)
                .join(rowEdge)
                .join(page2)
                .join(page1);

// The following method commits the current Transaction.
getContext().commit();

// Create a Cursor for the query.
CursorManager cursorMngr = dp.createCursorManager(cube);
CompoundCursor cubeCursor = (CompoundCursor) cursorMngr.createCursor();

// Display the values of the Cursor as a crosstab.
getContext().displayCursorAsCrosstab(cubeCursor);

// Change the customer parameter value.
custParam.setValue("SHIPMENTS::REGION::AMER");

// Reset the Cursor position to 1 and display the values again.
cubeCursor.setPosition(1);
println();
getContext().displayCursorAsCrosstab(cubeCursor);

// Pivot the column and row edges.
columnEdge = timeSel.join(timeShortDescr);
rowEdge = chanSel.join(chanShortDescr);

// Join the dimension selections to the measure.
cube = units.join(columnEdge)
                .join(rowEdge)
                .join(page2)
                .join(page1);

// Commit the current Transaction.
getContext().commit();

// Create another Cursor.
cursorMngr = dp.createCursorManager(cube);
cubeCursor = (CompoundCursor) cursorMngr.createCursor();
getContext().displayCursorAsCrosstab(cubeCursor);

// Change the product parameter value.
prodParam.setValue("PRODUCT_PRIMARY::FAMILY::DTPC");

// Reset the Cursor position to 1
cubeCursor.setPosition(1);
println();
getContext().displayCursorAsCrosstab(cubeCursor);
```

The following crosstab has the values of `cubeCursor` displayed by the first `displayCursorAsCrosstab` method.

```
Portable PCs
Europe

      Catalog  Direct Sales  Internet
```

1999	1986	86	0
2000	1777	193	10
2001	1449	196	215

The following crosstab has the values of `cubeCursor` after the example changed the value of the `custParam` Parameter object.

```
Portable PCs
North America
```

	Catalog	Direct Sales	Internet
1999	6841	385	0
2000	6457	622	35
2001	5472	696	846

The next crosstab has the values of `cubeCursor` after pivoting the column and row edges.

```
Portable PCs
North America
```

	1999	2000	2001
Catalog	6841	6457	5472
Direct Sales	385	622	696
Internet	0	35	846

The last crosstab has the values of `cubeCursor` after changing the value of the `prodParam` Parameter object.

```
Desktop PCs
North America
```

	1999	2000	2001
Catalog	14057	13210	11337
Direct Sales	793	1224	1319
Internet	0	69	1748

### 6.3.3 Drilling Up and Down in a Hierarchy

Drilling up or down in a dimension hierarchy is another typical OLAP operation. [Example 6-10](#) (page 6-18) demonstrates getting the members of one level of a dimension hierarchy, selecting a member, and then getting the parent, children, and ancestors of the member. The example gets the children of a parent by reversing the parent relation to produce the `prodHierChildren` Source.

The example uses the following objects.

- `levelSrc`, which is the Source for the FAMILY level of the PRODUCT\_PRIMARY hierarchy of the PRODUCT\_AWJ dimension.
- `prodHier`, which is the Source for the PRODUCT\_PRIMARY hierarchy.
- `prodHierParentAttr`, which is the Source for the parent attribute of the hierarchy.
- `prodHierAncsAttr`, which is the Source for the ancestors attribute of the hierarchy.
- `prodShortLabel`, which is the Source for the short value description attribute of the PRODUCT\_AWJ dimension.

**Example 6-10 Drilling in a Hierarchy**

```

int pos = 5;
// Get the element at the specified position of the level Source.
Source levelElement = levelSrc.at(pos);

// Get ancestors of the level member.
Source levelElementAncs = prodHierAncsAttr.join(prodHier, levelElement);
// Get the parent of the level member.
Source levelElementParent = prodHierParentAttr.join(prodHier, levelElement);
// Get the children of a parent.
Source prodHierChildren = prodHier.join(prodHierParentAttr, prodHier.value());

// Select the children of the level member.
Source levelElementChildren = prodHierChildren.join(prodHier, levelElement);

// Get the short value descriptions for the members of the level.
Source levelSrcWithShortDescr = prodShortLabel.join(levelSrc);

// Get the short value descriptions for the children.
Source levelElementChildrenWithShortDescr =
    prodShortLabel.join(levelElementChildren);

// Get the short value descriptions for the parents.
Source levelElementParentWithShortDescr =
    prodShortLabel.join(prodHier, levelElementParent, true);

// Get the short value descriptions for the ancestors.
Source levelElementAncsWithShortDescr =
    prodShortLabel.join(prodHier, levelElementAncs, true);

// Commit the current Transaction.
getContext().commit();

// Create Cursor objects and display their values.
println("Level Source element values:");
getContext().displayResult(levelSrcWithShortDescr);
println("\nLevel Source element at position " + pos + ":");
getContext().displayResult(levelElement);
println("\nParent of the level member:");
getContext().displayResult(levelElementParentWithShortDescr);
println("\nChildren of the level member:");
getContext().displayResult(levelElementChildrenWithShortDescr);
println("\nAncestors of the level member:");
getContext().displayResult(levelElementAncsWithShortDescr);

```

The following list has the values of the Cursor objects created by the `displayResults` methods.

```

Level Source element values:
PRODUCT_PRIMARY::FAMILY::ACC,Accessories
PRODUCT_PRIMARY::FAMILY::DISK,CD/DVD
PRODUCT_PRIMARY::FAMILY::DOC,Documentation
PRODUCT_PRIMARY::FAMILY::DTPC,Portable PCs
PRODUCT_PRIMARY::FAMILY::LTPC,Desktop PCs
PRODUCT_PRIMARY::FAMILY::MEM,Memory
PRODUCT_PRIMARY::FAMILY::MOD,Modems/Fax
PRODUCT_PRIMARY::FAMILY::MON,Monitors
PRODUCT_PRIMARY::FAMILY::OS,Operating Systems

```

```

Level Source element at position 5:
PRODUCT_PRIMARY::FAMILY:LTPC

```



```

Parent of the level member:
PRODUCT_PRIMARY::CLASS::HRD,Hardware

Children of the level member:
PRODUCT_PRIMARY::ITEM::ENVY ABM,Envoy Ambassador
PRODUCT_PRIMARY::ITEM::ENVY EXE,Envoy Executive
PRODUCT_PRIMARY::ITEM::ENVY STD,Envoy Standard

Ancestors of the level member:
PRODUCT_PRIMARY::TOTAL_PRODUCT::TOTAL,Total Product
PRODUCT_PRIMARY::CLASS::HRD,Hardware
PRODUCT_PRIMARY::FAMILY::LTPC,Portable PCs

```

### 6.3.4 Sorting Hierarchically by Measure Values

**Example 6-11** (page 6-19) uses the `recursiveJoin` method to sort the members of the `PRODUCT_PRIMARY` hierarchy of the `PRODUCT_AWJ` dimension hierarchically in ascending order of the values of the `UNITS` measure. The example joins the sorted products to the short value description attribute of the dimension, and then joins the result of that operation, `sortedProductsShortDescr`, to `units`.

The successive `joinHidden` methods join the selections of the other dimensions of `units` to produce the `result` `Source`, which has the measure data as element values and `sortedProductsShortDescr` as an output. The example uses the `joinHidden` methods so that the other dimension selections are not outputs of the result.

The example uses the following objects.

- `prodHier`, which is the `Source` for the `PRODUCT_PRIMARY` hierarchy.
- `units`, which is the `Source` for the `UNITS` measure of product units sold.
- `prodParentAttr`, which is the `Source` for the parent attribute of the `PRODUCT_PRIMARY` hierarchy.
- `prodShortDescr`, which is the `Source` for the short value description attribute of the `PRODUCT_AWJ` dimension.
- `custSel`, which is a `Source` that specifies a single member of the `SHIPMENTS` hierarchy of the `CUSTOMER_AWJ` dimension. The member is `SHIPMENTS::TOTAL_CUSTOMER::TOTAL`, which is the total for all customers.
- `chanSel`, which is a `Source` that specifies a single member of the `CHANNEL_PRIMARY` hierarchy of the `CHANNEL_AWJ` dimension. The member value is `CHANNEL_PRIMARY::CHANNEL::DIR`, which is the direct sales channel.
- `timeSel`, which is a `Source` that specifies a single member of the `CALENDAR_YEAR` hierarchy of the `TIME_AWJ` dimension. The member is `CALENDAR_YEAR::YEAR::CY2001`, which is the year 2001.

#### **Example 6-11 Hierarchical Sorting by Measure Value**

```

Source sortedProduct =
  prodHier.recursiveJoin(units,
                        units.getDataType(),
                        prodParentAttr,
                        Source.COMPARISON_RULE_ASCENDING,
                        true, // Parents first
                        true); // Restrict parents to base

```

```

Source sortedProductShortDescr = prodShortDescr.join(sortedProduct);
Source result = units.join(sortedProductShortDescr)
                .joinHidden(custSel)
                .joinHidden(chanSel)
                .joinHidden(timeSel);

```

A Cursor for the `result` Source has the following values, displayed in a table with column headings and formatting added. The left column has the name of the level in the `PRODUCT_PRIMARY` hierarchy. The next column to the right has the product identification value, and the next column has the short value description of the product. The rightmost column has the number of units of the product sold to all customers in the year 2001 through the direct sales channel.

The table contains only the first nine and the last eleven values of the Cursor, plus the Software/Other class value. The product values are listed hierarchically and in ascending order by units sold. The Hardware class appears before the Software/Other class because the Software/Other class has a greater number of units sold. In the Hardware class, the Portable PCs family sold the fewest units, so it appears first. In the Software/Other class, the Accessories family has the greatest number of units sold, so it appears last.

Product Level	ID	Description	Units Sold
TOTAL_PRODUCT	TOTAL	Total Product	43,785
CLASS	HRD	Hardware	16,543
FAMILY	LTPC	Portable PCs	1,192
ITEM	ENVY ABM	Envoy Ambassador	330
ITEM	ENVY EXE	Envoy Executive	385
ITEM	ENVY STD	Envoy Standard	477
FAMILY	MON	Monitors	1,193
ITEM	19 SVGA	Monitor- 19" Super VGA	207
ITEM	17 SVGA	Monitor- 17"Super VGA	986
...			
CLASS	SFT	Software/Other)	27,242
...			
FAMILY	ACC	Accessories	18,949
ITEM	ENVY EXT KBD	Envoy External Keyboard	146
ITEM	EXT KBD	External 101-key keyboard	678
ITEM	MM SPKR 5	Multimedia speakers- 5" cones	717
ITEM	STD MOUSE	Standard Mouse	868
ITEM	MM SPKR 3	Multimedia speakers- 3" cones	1,120
ITEM	144MB DISK	1.44MB External 3.5" Diskette	1,145
TEM	KBRD REST	Keyboard Wrist Rest	2,231
ITEM	LT CASE	Laptop carrying case	3,704
ITEM	DLX MOUSE	Deluxe Mouse	3,884
ITEM	MOUSE PAD	Mouse Pad	4,456

### 6.3.5 Using NumberSource Methods To Compute the Share of Units Sold

[Example 6-12](#) (page 6-21) uses the `NumberSource` methods `div` and `times` to produce a Source that specifies the share that the Desktop PC and Portable PC families have of the total quantity of product units sold for the selected time, customer, and channel values. The example first uses the `selectValue` method of `prodHier`, which is the Source for a hierarchy of the `PRODUCT_AWJ` dimension, to produce `totalProds`, which specifies a single element with the value `PRODUCT_PRIMARY::TOTAL_PRODUCT::TOTAL`, which is the highest aggregate level of the hierarchy.

The `joinHidden` method of the `NumberSource` `units` produces `totalUnits`, which specifies the `UNITS` measure values at the total product level, without having

`totalProds` appear as an output of `totalUnits`. The `div` method of `units` then produces a `Source` that represents each units sold value divided by the total quantity of units sold. The `times` method then multiplies the result of that `div` operation by 100 to produce `productShare`, which represents the percentage, or share, that a product member has of the total quantity of units sold. The `productShare` `Source` has the inputs of the `units` measure as inputs.

The `prodFamilies` object is the `Source` for the FAMILY level of the PRODUCT\_PRIMARY hierarchy. The `join` method of `productShare`, with `prodFamilies` as the joined `Source`, produces a `Source` that specifies the share that each product family has of the total quantity of products sold.

The `custSel`, `chanSel`, and `timeSel` `Source` objects are selections of single members of hierarchies of the CUSTOMER\_AWJ, CHANNEL\_AWJ, and TIME\_AWJ dimensions. The remaining `join` methods match those `Source` objects to the other inputs of `productShare`, to produce `result`. The `join(Source joined, String comparison)` signature of the `join` method produces a `Source` that does not have the joined `Source` as an output.

The `result` `Source` specifies the share for each product family of the total quantity of products sold to all customers through the direct sales channel in the year 2001.

#### Example 6-12 Getting the Share of Units Sold

```
Source totalProds =
    prodHier.selectValue("PRODUCT_PRIMARY::TOTAL_PRODUCT::TOTAL");
NumberSource totalUnits = (NumberSource) units.joinHidden(totalProds);
Source productShare = units.div(totalUnits).times(100);
Source result =
    productShare.join(prodFamilies)
        .join(timeHier, "CALENDAR_YEAR::YEAR::CY2001")
        .join(chanHier, "CHANNEL_PRIMARY::CHANNEL::DIR")
        .join(custHier, "SHIPMENTS::TOTAL_CUSTOMER::TOTAL");
Source sortedResult = result.sortAscending();
```

A `Cursor` for the `sortedResult` `Source` has the following values, displayed in a table with column headings and formatting added. The left column has the product family value and the right column has the share of the total number of units sold for the product family to all customers through the direct sales channel in the year 2001.

Product Family Member	Share of Total Units Sold
PRODUCT_PRIMARY::FAMILY::LTPC	2.72%
PRODUCT_PRIMARY::FAMILY::MON	2.73%
PRODUCT_PRIMARY::FAMILY::MEM	3.57%
PRODUCT_PRIMARY::FAMILY::DTPC	5.13%
PRODUCT_PRIMARY::FAMILY::DOC	6.4%
PRODUCT_PRIMARY::FAMILY::DISK	11.71%
PRODUCT_PRIMARY::FAMILY::MOD	11.92%
PRODUCT_PRIMARY::FAMILY::OS	12.54%
PRODUCT_PRIMARY::FAMILY::ACC	43.28%

### 6.3.6 Selecting Based on Time Series Operations

This topic has two examples of using methods that operate on a series of elements of the `MdmLevelHierarchy` for the CALENDAR\_YEAR hierarchy of the TIME\_AWJ dimension. [Example 6-13](#) (page 6-22) uses the `lag` method of `unitPrice`, which is the `Source` for the UNIT\_PRICE measure, to produce `unitPriceLag4`, which specifies, for each element of `unitPrice` that matches with a member of the

hierarchy, the element of `unitPrice` that matches with the hierarchy member that is four time periods earlier at the same level in the hierarchy.

In the example, `dp` is the `DataProvider`. The `createListSource` method creates `measuresDim`, which has the `unitPrice` and `unitPriceLag4` `Source` objects as element values. The `extract` method of `measuresDim` gets the values of the elements of `measuresDim`. The `Source` produced by the `extract` method has `measuresDim` as an extraction input. The first `join` method matches a `Source`, `measuresDim`, to the input of the `Source` returned by the `extract` method.

The `unitPrice` and `unitPriceLag4` measures both have the `Source` objects for the `PRODUCT_AWJ` and `TIME_AWJ` dimensions as inputs. The second `join` method matches `quarterLevel`, which is a `Source` for the `QUARTER` level of the `CALENDAR_YEAR` hierarchy of the `TIME_AWJ` dimension, with the `TIME_AWJ` dimension input of the measure, and makes it an output of the resulting `Source`.

The `joinHidden` method matches `prodSel` with the `PRODUCT_AWJ` dimension input of the measure, and does not make `prodSel` an output of the resulting `Source`. The `prodSel` `Source` specifies the single hierarchy member `PRODUCT_PRIMARY::FAMILY::DTPC`, which is Desktop PCs.

The `lagResult` `Source` specifies the aggregate unit prices for the Desktop PC product family for each quarter and the quarter that is four quarters earlier.

#### Example 6-13 Using the Lag Method

```
NumberSource unitPriceLag4 = unitPrice.lag(mdmCalHier, 4);
Source measuresDim = dp.createListSource(new Source[] {unitPrice,
                                                    unitPriceLag4});

Source lagResult = measuresDim.extract()
    .join(measuresDim)
    .join(quarterLevel)
    .joinHidden(prodSel);
```

A `Cursor` for the `lagResult` `Source` has the following values, displayed in a table with column headings and formatting added. The left column has the quarter, the middle column has the total of the unit prices for the members of the Desktop PC family for that quarter, and the right column has the total of the unit prices for the quarter that is four quarters earlier. The first four values in the right column are `NA` because quarter 5, Q1-98, is the first quarter in the `CALENDAR_YEAR` hierarchy. The table includes only the first eight quarters.

Quarter	Unit Price	Unit Price Four Quarters Before
CALENDAR_YEAR::QUARTER::CY1998.Q1	2687.54	NA
CALENDAR_YEAR::QUARTER::CY1998.Q2	2704.48	NA
CALENDAR_YEAR::QUARTER::CY1998.Q3	2673.27	NA
CALENDAR_YEAR::QUARTER::CY1998.Q4	2587.76	NA
CALENDAR_YEAR::QUARTER::CY1999.Q1	2394.79	2687.54
CALENDAR_YEAR::QUARTER::CY1999.Q2	2337.18	2704.48
CALENDAR_YEAR::QUARTER::CY1999.Q3	2348.39	2673.27
CALENDAR_YEAR::QUARTER::CY1999.Q4	2177.89	2587.76
...		

#### Example 6-14 Using the movingTotal Method

This example uses the same `unitPrice`, `mdmCalHier`, `quarterLevel`, and `prodSel` objects as [Example 6-13](#) (page 6-22), but it uses the `unitPriceMovingTotal` measure as the second element of `measuresDim`. The

`unitPriceMovingTotal` Source is produced by the `movingTotal` method of `unitPrice`. That method provides `mdmCalHier`, which is the `MdmLevelHierarchy` for the `CALENDAR_YEAR` hierarchy of the `TIME_AWJ` dimension, as the dimension parameter and the integers 0 and 3 as the starting and ending offset values.

The `movingTotalResult` Source specifies, for each quarter, the aggregate of the unit prices for the members of the Desktop PC family for that quarter and the total of that unit price plus the unit prices for the next three quarters.

```
NumberSource unitPriceMovingTotal =
    unitPrice.movingTotal(mdmCalHier, 0, 3);

Source measuresDim =
    dp.createListSource(new Source[]{unitPrice, unitPriceMovingTotal});

Source movingTotalResult = measuresDim.extract()
    .join(measuresDim)
    .join(quarterLevel)
    .joinHidden(prodSel);
```

A Cursor for the `movingTotalResult` Source has the following values, displayed in a table with column headings and formatting added. The left column has the quarter, the middle column has the total of the unit prices for the members of the Desktop PC family for that quarter, and the left column has the total of the unit prices for that quarter and the next three quarters. The table includes only the first eight quarters.

Quarter	Unit Price Moving Total	
	Unit Price	Current Plus Next Three Periods
CALENDAR_YEAR::QUARTER::CY1998.Q1	2687.54	10653.05
CALENDAR_YEAR::QUARTER::CY1998.Q2	2704.48	10360.30
CALENDAR_YEAR::QUARTER::CY1998.Q3	2673.27	9993.00
CALENDAR_YEAR::QUARTER::CY1998.Q4	2587.76	9668.12
CALENDAR_YEAR::QUARTER::CY1999.Q1	2394.79	9258.25
CALENDAR_YEAR::QUARTER::CY1999.Q2	2337.18	8911.87
CALENDAR_YEAR::QUARTER::CY1999.Q3	2348.39	8626.48
CALENDAR_YEAR::QUARTER::CY1999.Q4	2177.89	8291.37
...		

### 6.3.7 Selecting a Set of Elements Using Parameterized Source Objects

[Example 6-15](#) (page 6-24) uses `NumberParameter` objects to create parameterized Source objects. Those objects are the bottom and top parameters for the `interval` method of `prodHier`. That method returns `paramProdSelInterval`, which is a Source that specifies the set of elements of `prodHier` from the bottom to the top positions of the hierarchy.

The elements of the product Source specify the elements of the `units` measure that appear in the `result` Source. By changing the values of the `Parameter` objects, you can select a different set of units sold values using the same `Cursor` and without having to produce new `Source` and `Cursor` objects.

The example uses the following objects.

- `dp`, which is the `DataProvider` for the session.
- `prodHier`, which is the Source for the `PRODUCT_PRIMARY` hierarchy of the `PRODUCT_AWJ` dimension.

- `prodShortDescr`, which is the `Source` for the short value description attribute of the `PRODUCT_AWJ` dimension.
- `units`, which is the `Source` for the `UNITS` measure of product units sold.
- `chanHier`, which is the `Source` for the `CHANNEL_PRIMARY` hierarchy of the `CHANNEL_AWJ` dimension.
- `calHier`, which is the `Source` for the `CALENDAR_YEAR` hierarchy of the `TIME_AWJ` dimension.
- `shipHier`, which is the `Source` for the `SHIPMENTS` hierarchy of the `CUSTOMER_AWJ` dimension.
- The `Context11g` object that is returned by the `getContext` method. The `Context11g` has methods that commit the current `Transaction`, that create a `Cursor` for a `Source`, that display text, and that display the values of the `Cursor`.

The `join` method of `prodShortDescr` gets the short value descriptions for the elements of `paramProdSelInterval`. The next four `join` methods match `Source` objects with the inputs of the `units` measure. The example creates a `Cursor` and displays the result set of the query. Next, the `setPosition` method of `resultCursor` sets the position of the `Cursor` back to the first element.

The `setValue` methods of the `NumberParameter` objects change the values of those objects, which changes the selection of elements of the product `Source` that are specified by the query. The example then displays the values of the `Cursor` again.

**Example 6-15 Selecting a Range With NumberParameter Objects**

```
NumberParameter startParam = new NumberParameter(dp, 1);
NumberParameter endParam = new NumberParameter(dp, 6);

NumberSource startParamSrc = (NumberSource)startParam.createSource();
NumberSource endParamSrc = (NumberSource)endParam.createSource();

Source paramProdSelInterval =
    prodHier.interval(startParamSrc, endParamSrc);
Source paramProdSelIntervalShortDescr =
    prodShortDescr.join(paramProdSelInterval);

NumberSource result =
    (NumberSource)units.join(chanHier, "CHANNEL_PRIMARY::CHANNEL::INT")
        .join(calHier, "CALENDAR_YEAR::YEAR::CY2001")
        .join(shipHier, "SHIPMENTS::TOTAL_CUSTOMER::TOTAL")
        .join(paramProdSelIntervalShortDescr);

// Commit the current transaction.
getContext().commit();

CursorManager cursorMgr = dp.createCursorManager(result);
Cursor resultCursor = cursorMgr.createCursor();

getContext().displayCursor(resultCursor);

//Reset the Cursor position to 1.
resultCursor.setPosition(1);

// Change the value of the parameterized Source.
startParam.setValue(7);
endParam.setValue(12);
```

```
// Display the results again.
getContext().displayCursor(resultsCursor);
```

The following table displays the values of `resultCursor`, with column headings and formatting added. The left column has the product hierarchy members, the middle column has the short value description, and the right column has the quantity of units sold.

Product	Description	Units Sold
PRODUCT_PRIMARY::TOTAL_PRODUCT::TOTAL	Total Product	55,872
PRODUCT_PRIMARY::CLASS::HRD	Hardware	21,301
PRODUCT_PRIMARY::FAMILY::DISK	Memory	6,634
PRODUCT_PRIMARY::ITEM::EXT CD ROM	External 48X CD-ROM	136
PRODUCT_PRIMARY::ITEM::EXT DVD	External - DVD-RW - 8X	1,526
PRODUCT_PRIMARY::ITEM::INT 8X DVD	Internal - DVD-RW - 8X	1,543

Product	Description	Units Sold
PRODUCT_PRIMARY::ITEM::INT CD ROM	Internal 48X CD-ROM	380
PRODUCT_PRIMARY::ITEM::INT CD USB	Internal 48X CD-ROM USB	162
PRODUCT_PRIMARY::ITEM::INT RW DVD	Internal - DVD-RW - 6X	2,887
PRODUCT_PRIMARY::FAMILY::DTPC	Desktop PCs	2,982
PRODUCT_PRIMARY::ITEM::SENT FIN	Sentinel Financial	1,015
PRODUCT_PRIMARY::ITEM::SENT MM	Sentinel Multimedia	875





---

## Using a TransactionProvider

This chapter describes the Oracle OLAP Java API `Transaction` and `TransactionProvider` interfaces and describes how you use implementations of those interfaces in an application. You get a `TransactionProvider` from a `DataProvider`. You use the `commitCurrentTransaction` method of the `TransactionProvider` to save a metadata object in persistent storage in the database. You also use that method after creating a derived `Source` and before creating a `Cursor` for the `Source`. For examples of committing a `Transaction` after creating a metadata object, see [Creating Metadata and Analytic Workspaces](#) (page 4-1).

This chapter includes the following topics:

- [About Creating a Metadata Object or a Query in a Transaction](#) (page 7-1)
- [Using TransactionProvider Objects](#) (page 7-7)

### 7.1 About Creating a Metadata Object or a Query in a Transaction

The Oracle OLAP Java API is transactional. Creating metadata objects or `Source` objects for a query occurs in the context of a `Transaction`. A `TransactionProvider` provides `Transaction` objects to the application and commits or discards those `Transaction` objects.

The `TransactionProvider` ensures the following:

- A `Transaction` is isolated from other `Transaction` objects. Operations performed in a `Transaction` are not visible in, and do not affect, other `Transaction` objects.
- If an operation in a `Transaction` fails, then the effects of the operation are undone (the `Transaction` is rolled back).
- The effects of a completed `Transaction` persist.

When you create a `DataProvider` and `UserSession`, the session does not at first have a `Transaction`. The first `Transaction` in a session is a root `Transaction`. You can explicitly create a root `Transaction` by calling the `createRootTransaction` method of the `TransactionProvider`. If you do not explicitly create one, then Oracle OLAP automatically creates a root `Transaction` the first time that you create or modify an `MdmObject` or a derived `Source`. To make permanent the changes to an `MdmObject`, you must commit the root `Transaction` in which you made the changes.

A single-user application does not need to explicitly create a root `Transaction`. The ability to create multiple root `Transaction` objects is provided for use by multithreaded, middle-tier applications. If your application uses multiple root `Transaction` objects, the changes that the application makes in one root

Transaction can be overwritten by changes the application makes in another root Transaction. The changes that occur in the last root Transaction that the application commits are the changes that persist.

When you or Oracle OLAP creates the initial root Transaction, it is the *current* Transaction. If you create another root Transaction, it becomes the current Transaction.

Oracle OLAP creates other Transaction objects as you create Source objects or child Transaction objects under a root Transaction. You must commit the root Transaction for the Oracle Database to add to persistent storage any metadata objects that you have created in any Transaction in the session.

When you create a derived Source by calling a method of another Source, the derived Source is created in the context of the current Transaction. The Source is *active* in the Transaction in which you create it or in a child Transaction of that Transaction.

You get or set the current Transaction, or begin a child Transaction, by calling methods of a TransactionProvider. In a child Transaction you can alter a query, for example by changing the selection of dimension elements or by performing a different mathematical or analytical operation on the data, which changes the state of a Template that you created in the parent Transaction. By displaying the data specified by the Source produced by the Template in the parent Transaction and also displaying the data specified by the Source produced by the Template in the child Transaction, you can provide the end user of your application with the means of easily altering a query and viewing the results of different operations on the same set of data, or the same operations on different sets of data.

### 7.1.1 Types of Transaction Objects

The OLAP Java API has the following two types of Transaction objects:

- A read Transaction. Initially, the current Transaction is a read Transaction. A read Transaction is required for creating a Cursor to fetch data from Oracle OLAP. For more information on Cursor objects, see [Retrieving Query Results](#) (page 9-1).
- A write Transaction. A write Transaction is required for creating a derived Source or for changing the state of a Template. For more information on creating a derived Source, see [Understanding Source Objects](#) (page 5-1). For information on Template objects, see [Creating Dynamic Queries](#) (page 10-1).

In the initial read Transaction, if you create a derived Source or if you change the state of a Template object, then a child write Transaction is automatically generated. That child Transaction becomes the current Transaction.

If you then create another derived Source or change the Template state again, then that operation occurs in the same write Transaction. You can create any number of derived Source objects, or make any number of Template state changes, in that same write Transaction. You can use those Source objects, or the Source produced by the Template, to define a complex query.

Before you can create a Cursor to fetch the result set specified by a derived Source, you must move the Source from the child write Transaction into the parent read Transaction. To do so, you commit the Transaction.

## 7.1.2 Committing a Transaction

To move a Source that you created in a child Transaction into the parent read Transaction, call the `commitCurrentTransaction` method of the `TransactionProvider`. When you commit a child write Transaction, a Source you created in the child Transaction moves into the parent read Transaction. The child Transaction disappears and the parent Transaction becomes the current Transaction. The Source is active in the current read Transaction and you can therefore create a Cursor for it.

### **Example 7-1 Committing the Current Transaction**

In this example, `commit()` is a method that commits the current Transaction. In the example, `dp` is the `DataProvider`.

```
private void commit()
{
    try
    {
        (dp.getTransactionProvider()).commitCurrentTransaction();
    }
    catch (Exception ex)
    {
        System.out.println("Could not commit the Transaction. " + ex);
    }
}
```

## 7.1.3 About Transaction and Template Objects

Getting and setting the current Transaction, beginning a child Transaction, and rolling back a Transaction are operations that you use to allow an end user to make different selections starting from a given state of a dynamic query.

To present the end user with alternatives based on the same initial query, you do the following:

1. Create a Template in a parent Transaction and set the initial state for the Template.
2. Get the Source produced by the Template, create a Cursor to retrieve the result set, get the values from the Cursor, and then display the results to the end user.
3. Begin a child Transaction and modify the state of the Template.
4. Get the Source produced by the Template in the child Transaction, create a Cursor, get the values, and display them.

You can then replace the first Template state with the second one or discard the second one and retain the first.

## 7.1.4 Beginning a Child Transaction

To begin a child read Transaction, call the `beginSubtransaction` method of the `TransactionProvider` you are using. In the child read Transaction, if you change the state of a Template, then a child write Transaction begins automatically. The write Transaction is a child of the child read Transaction.

To get the data specified by the `Source` produced by the `Template`, you commit the write `Transaction` into the parent read `Transaction`. You can then create a `Cursor` to fetch the data. The changed state of the `Template` is not visible in the original parent. The changed state does not become visible in the parent until you commit the child read `Transaction` into the parent read `Transaction`.

After beginning a child read `Transaction`, you can begin a child read `Transaction` of that child, or a grandchild of the initial parent `Transaction`. For an example of creating child and grandchild `Transaction` objects, see [Example 7-3](#) (page 7-7).

## 7.1.5 About Rolling Back a Transaction

You roll back, or undo, a `Transaction` by calling the `rollbackCurrentTransaction` method of the `TransactionProvider` you are using. Rolling back a `Transaction` discards any changes that you made during that `Transaction` and makes the `Transaction` disappear.

Before rolling back a `Transaction`, you must close any `CursorManager` objects you created in that `Transaction`. After rolling back a `Transaction`, any `Source` objects that you created or `Template` state changes that you made in the `Transaction` are no longer valid. Any `Cursor` objects you created for those `Source` objects are also invalid.

Once you roll back a `Transaction`, you cannot commit that `Transaction`. Likewise, once you commit a `Transaction`, you cannot roll it back.

### **Example 7-2 Rolling Back a Transaction**

This example uses the `TopBottomTemplate` and `SingleSelectionTemplate` classes that are described in [Creating Dynamic Queries](#) (page 10-1). In creating the `TopBottomTemplate` and `SingleSelectionTemplate` objects, the example uses the same code that appears in [Example 10-4](#) (page 10-10). This example does not show that code. It sets the state of the `TopBottomTemplate`. It begins a child `Transaction` that sets a different state for the `TopBottomTemplate` and then rolls back the child `Transaction`. The `println` method displays text through a `CursorPrintWriter` object and the `getContext` method gets a `Context11g` object that has methods that create `Cursor` objects and display their values through the `CursorPrintWriter`. The `CursorPrintWriter` and `Context11g` classes are used by the example programs in this documentation.

```
// The current Transaction is a read Transaction, t1.
// Create a TopBottomTemplate using a hierarchy of the PRODUCT_AWJ dimension
// as the base and dp as the DataProvider.
TopBottomTemplate topNBottom = new TopBottomTemplate(prodHier, dp);

// Changing the state of a Template requires a write Transaction, so a
// write child Transaction, t2, is automatically started.
topNBottom.setTopBottomType(TopBottomTemplate.TOP_BOTTOM_TYPE_TOP);
topNBottom.setN(10);
topNBottom.setCriterion(singleSelections.getSource());

// Get the TransactionProvider and commit the Transaction t2.
TransactionProvider tp = dp.getTransactionProvider();
try
{
    tp.commitCurrentTransaction();           // t2 disappears
}
catch(Exception e)
{
    println("Cannot commit the Transaction. " + e);
}
```

```

}

// The current Transaction is now t1.
// Get the dynamic Source produced by the TopBottomTemplate.
Source result = topNBottom.getSource();

// Create a Cursor and display the results
println("\nThe current state of the TopBottomTemplate" +
        "\nproduces the following values:\n");
getContext().displayTopBottomResult(result);

// Start a child Transaction, t3. It is a read Transaction.
tp.beginSubtransaction();          // t3 is the current Transaction

// Change the state of topNBottom. Changing the state requires a
// write Transaction so Transaction t4 starts automatically.
topNBottom.setTopBottomType(TopBottomTemplate.TOP_BOTTOM_TYPE_BOTTOM);
topNBottom.setN(15);

// Commit the Transaction.
try
{
    tp.commitCurrentTransaction();    // t4 disappears
}
catch(Exception e)
{
    println("Cannot commit the Transaction. " + e);
}

// Create a Cursor and display the results. // t3 is the current Transaction
println("\nIn the child Transaction, the state of the" +
        "\nTopBottomTemplate produces the following values:\n");
getContext().displayTopBottomResult(result);
// The displayTopBottomResult method closes the CursorManager for the
// Cursor created in t3.

// Undo t3, which discards the state of topNBottom that was set in t4.
tp.rollbackCurrentTransaction();    // t3 disappears

// Transaction t1 is now the current Transaction and the state of
// topNBottom is the one defined in t2.

// To show the current state of the TopNBottom template Source, commit
// the Transaction, create a Cursor, and display the Cursor values.
try
{
    tp.commitCurrentTransaction();
}
catch(Exception e)
{
    println("Cannot commit the Transaction. " + e);
}

println("\nAfter rolling back the child Transaction, the state of"
        + "\nthe TopBottomTemplate produces the following values:\n");
getContext().displayTopBottomResult(result);

```

The example produces the following output.

The current state of the TopBottomTemplate produces the following values:

1. PRODUCT\_PRIMARY::TOTAL\_PRODUCT::TOTAL
2. PRODUCT\_PRIMARY::CLASS::SFT
3. PRODUCT\_PRIMARY::FAMILY::ACC
4. PRODUCT\_PRIMARY::CLASS::HRD
5. PRODUCT\_PRIMARY::FAMILY::MOD
6. PRODUCT\_PRIMARY::FAMILY::OS
7. PRODUCT\_PRIMARY::FAMILY::DISK
8. PRODUCT\_PRIMARY::ITEM::MOUSE PAD
9. PRODUCT\_PRIMARY::ITEM::OS 1 USER
10. PRODUCT\_PRIMARY::ITEM::DLX MOUSE

In the child Transaction, the state of the TopBottomTemplate produces the following values:

1. PRODUCT\_PRIMARY::ITEM::EXT CD ROM
2. PRODUCT\_PRIMARY::ITEM::OS DOC ITA
3. PRODUCT\_PRIMARY::ITEM::OS DOC SPA
4. PRODUCT\_PRIMARY::ITEM::INT CD USB
5. PRODUCT\_PRIMARY::ITEM::ENVY EXT KBD
6. PRODUCT\_PRIMARY::ITEM::19 SVGA
7. PRODUCT\_PRIMARY::ITEM::OS DOC FRE
8. PRODUCT\_PRIMARY::ITEM::OS DOC GER
9. PRODUCT\_PRIMARY::ITEM::ENVY ABM
10. PRODUCT\_PRIMARY::ITEM::INT CD ROM
11. PRODUCT\_PRIMARY::ITEM::ENVY EXE
12. PRODUCT\_PRIMARY::ITEM::OS DOC KAN
13. PRODUCT\_PRIMARY::ITEM::ENVY STD
14. PRODUCT\_PRIMARY::ITEM::1GB USB DRV
15. PRODUCT\_PRIMARY::ITEM::SENT MM

After rolling back the child Transaction, the state of the TopBottomTemplate produces the following values:

1. PRODUCT\_PRIMARY::TOTAL\_PRODUCT::TOTAL
2. PRODUCT\_PRIMARY::CLASS::SFT
3. PRODUCT\_PRIMARY::FAMILY::ACC
4. PRODUCT\_PRIMARY::CLASS::HRD
5. PRODUCT\_PRIMARY::FAMILY::MOD
6. PRODUCT\_PRIMARY::FAMILY::OS
7. PRODUCT\_PRIMARY::FAMILY::DISK
8. PRODUCT\_PRIMARY::ITEM::MOUSE PAD
9. PRODUCT\_PRIMARY::ITEM::OS 1 USER
10. PRODUCT\_PRIMARY::ITEM::DLX MOUSE

## 7.1.6 Getting and Setting the Current Transaction

You get the current Transaction by calling the `getCurrentTransaction` method of the `TransactionProvider` you are using, as in the following example.

```
Transaction t1 = tp.getCurrentTransaction();
```

To make a previously saved Transaction the current Transaction, you call the `setCurrentTransaction` method of the `TransactionProvider`, as in the following example.

```
tp.setCurrentTransaction(t1);
```

## 7.2 Using TransactionProvider Objects

In the Oracle OLAP Java API, a `DataProvider` provides an implementation of the `TransactionProvider` interface. The `TransactionProvider` provides `Transaction` objects to your application.

As described in "[Committing a Transaction](#) (page 7-3)", you use the `commitCurrentTransaction` method to make a derived `Source` that you created in a child write `Transaction` visible in the parent read `Transaction`. You can then create a `Cursor` for that `Source`.

If you are using `Template` objects in your application, then you might also use the other methods of `TransactionProvider` to do the following:

- Begin a child `Transaction`.
- Get the current `Transaction` so you can save it.
- Set the current `Transaction` to a previously saved one.
- Rollback, or undo, the current `Transaction`, which discards any changes made in the `Transaction`. Once a `Transaction` has been rolled back, it is invalid and cannot be committed. Once a `Transaction` has been committed, it cannot be rolled back. If you created a `Cursor` for a `Source` in a `Transaction`, then you must close the `CursorManager` before rolling back the `Transaction`.

[Example 7-3](#) (page 7-7) demonstrates the use of `Transaction` objects to modify dynamic queries. Like [Example 7-2](#) (page 7-4), this example uses the same code to create `TopBottomTemplate` and `SingleSelectionTemplate` objects as does [Example 10-4](#) (page 10-10). This example does not show that code.

To help track the `Transaction` objects, this example saves the different `Transaction` objects with calls to the `getCurrentTransaction` method. In the example, the `tp` object is the `TransactionProvider`. The `println` method displays text through a `CursorPrintWriter` and the `getContext` method gets a `Context11g` object that has methods that create `Cursor` objects and display their values through the `CursorPrintWriter`. The `commit` method is the method from [Example 7-1](#) (page 7-3).

### **Example 7-3 Using Child Transaction Objects**

```
// The parent Transaction is the current Transaction at this point.
// Save the parent read Transaction as parentT1.
Transaction parentT1 = tp.getCurrentTransaction();

// Get the dynamic Source produced by the TopBottomTemplate.
Source result = topNBottom.getSource();

// Create a Cursor and display the results.
println("\n\nThe current state of the TopBottomTemplate" +
        "\n\nproduces the following values:\n");
getContext().displayTopBottomResult(result);

// Begin a child Transaction of parentT1.
tp.beginSubtransaction(); // This is a read Transaction.

// Save the child read Transaction as childT2.
Transaction childT2 = tp.getCurrentTransaction();

// Change the state of the TopBottomTemplate. This starts a
```

```
// write Transaction, a child of the read Transaction childT2.
topNBottom.setN(12);
topNBottom.setTopBottomType(TopBottomTemplate.TOP_BOTTOM_TYPE_BOTTOM);

// Save the child write Transaction as writeT3.
Transaction writeT3 = tp.getCurrentTransaction();

// Commit the write Transaction writeT3.
commit();

// The commit moves the changes made in writeT3 into its parent,
// the read Transaction childT2. The writeT3 Transaction
// disappears. The current Transaction is now childT2
// again but the state of the TopBottomTemplate has changed.

// Create a Cursor and display the results of the changes to the
// TopBottomTemplate that are visible in childT2.
try
{
    println("\nIn the child Transaction, the state of the" +
           "\nTopBottomTemplate produces the following values:\n");

    getContext().displayTopBottomResult(result);
}
catch(Exception e)
{
    println("Cannot display the results of the query. " + e);
}

// Begin a grandchild Transaction of the initial parent.
tp.beginSubtransaction(); // This is a read Transaction.

// Save the grandchild read Transaction as grandchildT4.
Transaction grandchildT4 = tp.getCurrentTransaction();

// Change the state of the TopBottomTemplate. This starts another
// write Transaction, a child of grandchildT4.
topNBottom.setTopBottomType(TopBottomTemplate.TOP_BOTTOM_TYPE_TOP);

// Save the write Transaction as writeT5.
Transaction writeT5 = tp.getCurrentTransaction();

// Commit writeT5.
commit();

// Transaction grandchildT4 is now the current Transaction and the
// changes made to the TopBottomTemplate state are visible.

// Create a Cursor and display the results visible in grandchildT4.
try
{
    println("\nIn the grandchild Transaction, the state of the" +
           "\nTopBottomTemplate produces the following values:\n");
    getContext().displayTopBottomResult(result);
}
catch(Exception e)
{
    println("Cannot display the results of the query. " + e);
}

// Commit the grandchild into the child.
```



```

commit();

// Transaction childT2 is now the current Transaction.
// Instead of preparing and committing the grandchild Transaction,
// you could rollback the Transaction, as in the following
// method call:
//   rollbackCurrentTransaction();
// If you roll back the grandchild Transaction, then the changes
// you made to the TopBottomTemplate state in the grandchild
// are discarded and childT2 is the current Transaction.

// Commit the child into the parent.
commit();

// Transaction parentT1 is now the current Transaction. Again,
// you can roll back the childT2 Transaction instead of committing it.
// If you do so, then the changes that you made in childT2 are discarded.
// The current Transaction is be parentT1, which has the original state
// of the TopBottomTemplate, without any of the changes made in the
// grandchild or the child transactions.

```

**Example 7-3** (page 7-7) produces the following output.

The current state of the TopBottomTemplate produces the following values:

1. PRODUCT\_PRIMARY::TOTAL\_PRODUCT::TOTAL
2. PRODUCT\_PRIMARY::CLASS::SFT
3. PRODUCT\_PRIMARY::FAMILY::ACC
4. PRODUCT\_PRIMARY::CLASS::HRD
5. PRODUCT\_PRIMARY::FAMILY::MOD
6. PRODUCT\_PRIMARY::FAMILY::OS
7. PRODUCT\_PRIMARY::FAMILY::DISK
8. PRODUCT\_PRIMARY::ITEM::MOUSE PAD
9. PRODUCT\_PRIMARY::ITEM::OS 1 USER
10. PRODUCT\_PRIMARY::ITEM::DLX MOUSE

In the child Transaction, the state of the TopBottomTemplate produces the following values:

1. PRODUCT\_PRIMARY::ITEM::EXT CD ROM
2. PRODUCT\_PRIMARY::ITEM::OS DOC ITA
3. PRODUCT\_PRIMARY::ITEM::OS DOC SPA
4. PRODUCT\_PRIMARY::ITEM::INT CD USB
5. PRODUCT\_PRIMARY::ITEM::ENVY EXT KBD
6. PRODUCT\_PRIMARY::ITEM::19 SVGA
7. PRODUCT\_PRIMARY::ITEM::OS DOC FRE
8. PRODUCT\_PRIMARY::ITEM::OS DOC GER
9. PRODUCT\_PRIMARY::ITEM::ENVY ABM
10. PRODUCT\_PRIMARY::ITEM::INT CD ROM
11. PRODUCT\_PRIMARY::ITEM::ENVY EXE
12. PRODUCT\_PRIMARY::ITEM::OS DOC KAN

In the grandchild Transaction, the state of the TopBottomTemplate produces the following values:

1. PRODUCT\_PRIMARY::TOTAL\_PRODUCT::TOTAL
2. PRODUCT\_PRIMARY::CLASS::SFT
3. PRODUCT\_PRIMARY::FAMILY::ACC
4. PRODUCT\_PRIMARY::CLASS::HRD
5. PRODUCT\_PRIMARY::FAMILY::MOD

6. PRODUCT\_PRIMARY::FAMILY::OS
7. PRODUCT\_PRIMARY::FAMILY::DISK
8. PRODUCT\_PRIMARY::ITEM::MOUSE PAD
9. PRODUCT\_PRIMARY::ITEM::OS 1 USER
10. PRODUCT\_PRIMARY::ITEM::DLX MOUSE
11. PRODUCT\_PRIMARY::ITEM::LT CASE
12. PRODUCT\_PRIMARY::ITEM::56KPS MODEM

---

# Understanding Cursor Classes and Concepts

This chapter describes the Oracle OLAP Java API `Cursor` class and the related classes that you use to retrieve the results of a query. This chapter also describes the `Cursor` concepts of position, fetch size, and extent. For examples of creating and using a `Cursor` and its related objects, see [Retrieving Query Results](#) (page 9-1).

This chapter includes the following topics:

- [Overview of the OLAP Java API Cursor Objects](#) (page 8-1)
- [Cursor Classes](#) (page 8-2)
- [CursorInfoSpecification Classes](#) (page 8-5)
- [CursorManager Class](#) (page 8-7)
- [About Cursor Positions and Extent](#) (page 8-7)
- [About Fetch Sizes](#) (page 8-13)

## 8.1 Overview of the OLAP Java API Cursor Objects

A `Cursor` retrieves the result set specified by a `Source`. You create a `Cursor` by calling the `createCursor` method of a `CursorManager`. You create a `CursorManager` by calling the `createCursorManager` method of a `DataProvider`.

You can get the SQL generated for a `Source` by the Oracle OLAP SQL generator without having to create a `Cursor`. To get the SQL for the `Source`, you create an `SQLCursorManager` by using a `createSQLCursorManager` method of a `DataProvider`. You can then use classes outside of the OLAP Java API, or other methods, to retrieve data using the generated SQL.

### 8.1.1 Creating a Cursor

You create a `Cursor` for a `Source` by doing the following:

1. Creating a `CursorManager` by calling one of the `createCursorManager` methods of the `DataProvider` and passing it the `Source`. If you want to alter the behavior of the `Cursor`, then you can create a `CursorInfoSpecification` and use the methods of it to specify the behavior. You then create a `CursorManager` with a method that takes the `Source` and the `CursorInfoSpecification`.
2. Creating a `Cursor` by calling the `createCursor` method of the `CursorManager`.

## 8.1.2 Sources For Which You Cannot Create a Cursor

Some `Source` objects do not specify data that a `Cursor` can retrieve from the data store. The following are `Source` objects for which you cannot create a `Cursor` that contains values.

- A `Source` that specifies an operation that is not computationally possible. An example is a `Source` that specifies an infinite recursion.
- A `Source` that defines an infinite result set. An example is the fundamental `Source` that represents the set of all `String` objects.
- A `Source` that has no elements or includes another `Source` that has no elements. Examples are a `Source` returned by the `getEmptySource` method of `DataProvider` and another `Source` derived from the empty `Source`. Another example is a derived `Source` that results from selecting a value from a primary `Source` that you got from an `MdmDimension` and the selected value does not exist in the dimension.

If you create a `Cursor` for such a `Source` and try to get the values of the `Cursor`, then an `Exception` occurs.

## 8.1.3 Cursor Objects and Transaction Objects

When you create a derived `Source` or change the state of a `Template`, you create the `Source` in the context of the current `Transaction`. The `Source` is active in the `Transaction` in which you create it or in a child `Transaction` of that `Transaction`. A `Source` must be active in the current `Transaction` for you to be able to create a `Cursor` for it.

Creating a derived `Source` occurs in a write `Transaction`. Creating a `Cursor` occurs in a read `Transaction`. After creating a derived `Source`, and before you can create a `Cursor` for that `Source`, you must change the write `Transaction` into a read `Transaction` by calling the `commitCurrentTransaction` methods of the `TransactionProvider` your application is using. For information on `Transaction` and `TransactionProvider` objects, see [Using a TransactionProvider](#) (page 7-1).

For a `Cursor` that you create for a query that includes a parameterized `Source`, you can change the value of the `Parameter` object and then get the new values of the `Cursor` without having to commit the `Transaction` again. For information on parameterized `Source` objects, see [Understanding Source Objects](#) (page 5-1).

## 8.2 Cursor Classes

In the `oracle.olapi.data.cursor` package, the Oracle OLAP Java API defines the interfaces described in the following table.

Interface	Description
<code>Cursor</code>	An abstract superclass that encapsulates the notion of a current position.
<code>ValueCursor</code>	A <code>Cursor</code> that has a value at the current position. A <code>ValueCursor</code> has no child <code>Cursor</code> objects.

Interface	Description
CompoundCursor	A Cursor that has child Cursor objects, which are a child ValueCursor for the values of the Source associated with it and an output child Cursor for each output of the Source.

## 8.2.1 Structure of a Cursor

The structure of a Cursor mirrors the structure of the Source associated with it. If the Source does not have any outputs, then the Cursor for that Source is a ValueCursor. If the Source has one or more outputs, then the Cursor for that Source is a CompoundCursor. A CompoundCursor has as children a base ValueCursor, which has the values of the base of the Source of the CompoundCursor, and one or more output Cursor objects.

The output of a Source is another Source. An output Source can itself have outputs. The child Cursor for an output of a Source is a ValueCursor if the output Source does not have any outputs and a CompoundCursor if it does.

[Example 8-1](#) (page 8-3) creates a query that specifies the prices of selected product items for selected months. In the example, `timeHier` is a Source for a hierarchy of a dimension of time values, and `prodHier` is a Source for a hierarchy of a dimension of product values.

If you create a Cursor for `prodSel` or for `timeSel`, then either Cursor is a ValueCursor because both `prodSel` and `timeSel` have no outputs.

The `unitPrice` object is a Source for an `MdmBaseMeasure` that represents values for the price of product units. The `MdmBaseMeasure` has as inputs the `MdmPrimaryDimension` objects representing products and times, and the `unitPrice` Source has as inputs the Source objects for those dimensions.

The example selects elements of the dimension hierarchies and then joins the Source objects for the selections to that of the measure to produce `querySource`, which has `prodSel` and `timeSel` as outputs.

### **Example 8-1** Creating the querySource Query

```
Source timeSel = timeHier.selectValues(new String[]
    { "CALENDAR_YEAR::MONTH::2001.01",
      "CALENDAR_YEAR::MONTH::2001.04",
      "CALENDAR_YEAR::MONTH::2001.07",
      "CALENDAR_YEAR::MONTH::2001.10" });

Source prodSel = prodHier.selectValues(new String[]
    { "PRODUCT_PRIMARY::ITEM::ENVY ABM",
      "PRODUCT_PRIMARY::ITEM::ENVY EXE",
      "PRODUCT_PRIMARY::ITEM::ENVY STD" });

Source querySource = unitPrice.join(timeSel).join(prodSel);
```

The result set defined by `querySource` is the unit price values for the selected products for the selected months. The results are organized by the outputs. Since `timeSel` is joined to the Source produced by the `unitPrice.join(prodSel)` operation, `timeSel` is the slower varying output, which means that the result set specifies the set of selected products for each selected time value. For each time value the result set has three product values so the product values vary faster than the time

values. The values of the base ValueCursor of querySource are the fastest varying of all, because there is one price value for each product for each day.

**Example 9-1** (page 9-1) in [Retrieving Query Results](#) (page 9-1), creates a Cursor, queryCursor, for querySource. Since querySource has outputs, queryCursor is a CompoundCursor. The base ValueCursor of queryCursor has values from unitPrice, which is the base Source of the operation that created querySource. The values from unitPrice are those specified by the outputs. The outputs for queryCursor are a ValueCursor that has values from prodSel and a ValueCursor that has values from timeSel.

**Figure 8-1 Structure of the queryCursor CompoundCursor**

This figure illustrates the structure of queryCursor. The base ValueCursor and the two output ValueCursor objects are the children of queryCursor, which is the parent CompoundCursor.

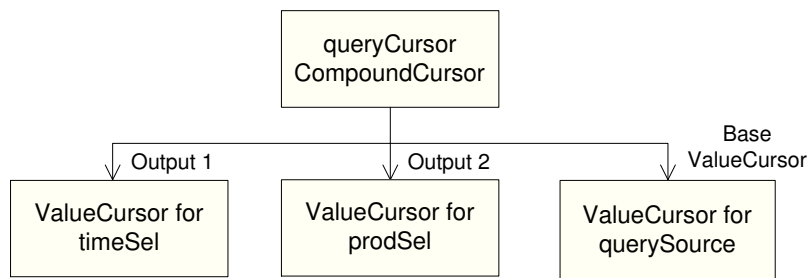

The following table displays the values from queryCursor in a table. The left column has time values, the middle column has product values, and the right column has the unit price of the product for the month.

Month	Product	Price of Unit
2001.01	ENVY ABM	3042.22
2001.01	ENVY EXE	3223.28
2001.01	ENVY STD	3042.22
2001.04	ENVY ABM	2412.42
2001.04	ENVY EXE	3107.65
2001.04	ENVY STD	3026.12
2001.07	ENVY ABM	2505.57
2001.07	ENVY EXE	3155.91
2001.07	ENVY STD	2892.18
2001.10	ENVY ABM	2337.30
2001.10	ENVY EXE	3105.53
2001.10	ENVY STD	2856.86

For examples of getting the values from a `ValueCursor`, see [Retrieving Query Results](#) (page 9-1).

## 8.2.2 Specifying the Behavior of a Cursor

`CursorSpecification` objects specify some aspects of the behavior of their corresponding `Cursor` objects. You must specify the behavior on a `CursorSpecification` before creating the corresponding `Cursor`. To specify the behavior, use the following `CursorSpecification` methods:

- `setDefaultFetchSize`
- `setExtentCalculationSpecified`
- `setParentEndCalculationSpecified`
- `setParentStartCalculationSpecified`
- `specifyDefaultFetchSizeOnChildren` (for a `CompoundCursorSpecification` only)

A `CursorSpecification` also has methods that you can use to discover if the behavior is specified. Those methods are the following:

- `isExtentCalculationSpecified`
- `isParentEndCalculationSpecified`
- `isParentStartCalculationSpecified`

If you have used the `CursorSpecification` methods to set the default fetch size, or to calculate the extent or the starting or ending positions of a value in the parent of the value, then you can successfully use the following `Cursor` methods:

- `getExtent`
- `getFetchSize`
- `getParentEnd`
- `getParentStart`
- `setFetchSize`

For examples of specifying `Cursor` behavior, see [Retrieving Query Results](#) (page 9-1). For information on fetch sizes, see "[About Fetch Sizes](#) (page 8-13)". For information on the extent of a `Cursor`, see "[What is the Extent of a Cursor?](#) (page 8-12)". For information on the starting and ending positions in a parent `Cursor` of the current value of a `Cursor`, see "[About the Parent Starting and Ending Positions in a Cursor](#) (page 8-12)".

## 8.3 CursorInfoSpecification Classes

The `CursorInfoSpecification` interface and the subinterfaces `CompoundCursorInfoSpecification` and `ValueCursorInfoSpecification`, specify methods for the abstract `CursorSpecification` class and the concrete `CompoundCursorSpecification` and `ValueCursorSpecification` classes. A `CursorSpecification` specifies certain aspects of the behavior of the `Cursor` that corresponds to it. You can create instances of classes that implement the `CursorInfoSpecification` interface either directly or indirectly.

You can create a `CursorSpecification` for a `Source` by calling the `createCursorInfoSpecification` method of a `DataProvider`. That method returns a `CompoundCursorSpecification` or a `ValueCursorSpecification`. You can use the methods of the `CursorSpecification` to specify aspects of the behavior of a `Cursor`. You can then use the `CursorSpecification` in creating a `CursorManager` by passing it as the `cursorInfoSpec` argument to the `createCursorManager` method of a `DataProvider`.

With `CursorSpecification` methods, you can do the following:

- Get the `Source` that corresponds to the `CursorSpecification`.
- Get or set the default fetch size for the corresponding `Cursor`.
- Specify that Oracle OLAP should calculate the extent of a `Cursor`.
- Determine whether calculating the extent is specified.
- Specify that Oracle OLAP should calculate the starting or ending position of the current value of the corresponding `Cursor` in the parent `Cursor`. If you know the starting and ending positions of a value in the parent, then you can determine how many faster varying elements the parent `Cursor` has for that value.
- Determine whether calculating the starting or ending position of the current value of the corresponding `Cursor` in the parent is specified.
- Accept a `CursorSpecificationVisitor`.

For more information, see "[About Cursor Positions and Extent](#) (page 8-7)" and "[About Fetch Sizes](#) (page 8-13)".

In the `oracle.olapi.data.source` package, the Oracle OLAP Java API defines the classes described in the following table.

Interface	Description
<code>CursorInfoSpecification</code>	An interface that specifies methods for <code>CursorSpecification</code> objects.
<code>CursorSpecification</code>	An abstract class that implements some methods of the <code>CursorInfoSpecification</code> interface.
<code>CompoundCursorSpecification</code>	A <code>CursorSpecification</code> for a <code>Source</code> that has one or more outputs. A <code>CompoundCursorSpecification</code> has component child <code>CursorSpecification</code> objects.
<code>CompoundInfoCursorSpecification</code>	An interface that specifies methods for <code>CompoundCursorSpecification</code> objects.
<code>ValueCursorSpecification</code>	A <code>CursorSpecification</code> for a <code>Source</code> that has values and no outputs.
<code>ValueCursorInfoSpecification</code>	An interface for <code>ValueCursorSpecification</code> objects.

A `Cursor` has the same structure as the `CursorSpecification`. Every `ValueCursorSpecification` or `CompoundCursorSpecification` has a



corresponding `ValueCursor` or `CompoundCursor`. To be able to get certain information or behavior from a `Cursor`, your application must specify that it wants that information or behavior by calling methods of the corresponding `CursorSpecification` before it creates the `Cursor`.

## 8.4 CursorManager Class

With a `CursorManager`, you can create a `Cursor` for a `Source`. The class returned by one of the `createCursorManager` methods of a `DataProvider` manages the buffering of data for the `Cursor` objects it creates.

You can create more than one `Cursor` from the same `CursorManager`, which is useful for displaying data from a result set in different formats such as a table or a graph. All of the `Cursor` objects created by a `CursorManager` have the same specifications, such as the default fetch sizes. Because the `Cursor` objects have the same specifications, they can share the data managed by the `CursorManager`.

A `SQLCursorManager` has methods that return the SQL generated by the Oracle OLAP SQL generator for a `Source`. You create one or more `SQLCursorManager` objects by calling the `createSQLCursorManager` or `createSQLCursorManagers` methods of a `DataProvider`. You do not use a `SQLCursorManager` to create a `Cursor`. Instead, you use the SQL returned by the `SQLCursorManager` with classes outside of the OLAP Java API, or by other means, to retrieve the data specified by the query.

### 8.4.1 Updating the CursorInfoSpecification for a CursorManager

If your application is using OLAP Java API `Template` objects and the state of a `Template` changes in a way that alters the structure of the `Source` produced by the `Template`, then any `CursorInfoSpecification` objects for the `Source` are no longer valid. You need to create new `CursorInfoSpecification` objects for the changed `Source`.

After creating a new `CursorInfoSpecification`, you can create a new `CursorManager` for the `Source`. You do not, however, need to create a new `CursorManager`. You can call the `updateSpecification` method of the existing `CursorManager` to replace the previous `CursorInfoSpecification` with the new `CursorInfoSpecification`. You can then create a new `Cursor` from the `CursorManager`.

## 8.5 About Cursor Positions and Extent

A `Cursor` has one or more positions. The current position of a `Cursor` is the position that is currently active in the `Cursor`. To move the current position of a `Cursor` call the `setPosition` or `next` methods of the `Cursor`.

Oracle OLAP does not validate the position that you set on the `Cursor` until you attempt an operation on the `Cursor`, such as calling the `getCurrentValue` method. If you set the current position to a negative value or to a value that is greater than the number of positions in the `Cursor` and then attempt a `Cursor` operation, then the `Cursor` throws a `PositionOutOfBoundsException`.

The extent of a `Cursor` is described in "[What is the Extent of a Cursor?](#) (page 8-12)".

### 8.5.1 Positions of a ValueCursor

The current position of a `ValueCursor` specifies a value, which you can retrieve. For example, `prodSel`, a derived `Source` described in "[Structure of a Cursor](#) (page 8-3)",

is a selection of three products from a primary `Source` that specifies a dimension of products and their hierarchical groupings. The `ValueCursor` for `prodSel` has three elements. The following example gets the position of each element of the `ValueCursor`, and displays the value at that position.

```
// prodSelValCursor is the ValueCursor for prodSel
println("ValueCursor Position Value ");
println("-----");
do
{
    println("      " + prodSelValCursor.getPosition() +
           "      " + prodSelValCursor.getCurrentValue());
} while(prodSelValCursor.next());
```

The preceding example displays the following:

ValueCursor Position	Value
-----	-----
1	PRODUCT_PRIMARY::ITEM::ENVY ABM
2	PRODUCT_PRIMARY::ITEM::ENVY EXE
3	PRODUCT_PRIMARY::ITEM::ENVY STD

The following example sets the current position of `prodSelValCursor` to 2 and retrieves the value at that position.

```
prodSelValCursor.setPosition(2);
println(prodSelValCursor.getCurrentString());
```

The preceding example displays the following:

```
PRODUCT_PRIMARY::ITEM::ENVY EXE
```

For more examples of getting the current value of a `ValueCursor`, see [Retrieving Query Results](#) (page 9-1).

## 8.5.2 Positions of a CompoundCursor

A `CompoundCursor` has one position for each set of the elements of the descendent `ValueCursor` objects. The current position of the `CompoundCursor` specifies one of those sets.

For example, `querySource`, the `Source` created in [Example 8-1](#) (page 8-3), has values from a measure, `unitPrice`. The values are the prices of product units at different times. The outputs of `querySource` are `Source` objects that represent selections of four month values from a time dimension and three product values from a product dimension.

The result set for `querySource` has one measure value for each tuple (each set of output values), so the total number of values is twelve (one value for each of the three products for each of the four months). Therefore, the `queryCursor` `CompoundCursor` created for `querySource` has twelve positions.

Each position of `queryCursor` specifies one set of positions of the outputs and the base `ValueCursor`. For example, position 1 of `queryCursor` defines the following set of positions for the outputs and the base `ValueCursor`:

- Position 1 of output 1 (the `ValueCursor` for `timeSel`)
- Position 1 of output 2 (the `ValueCursor` for `prodSel`)

- Position 1 of the base ValueCursor for queryCursor (This position has the value from the unitPrice measure that is specified by the values of the outputs.)

**Figure 8-2 Cursor Positions in queryCursor**

This example illustrates the positions of queryCursor CompoundCursor, the base ValueCursor, and the outputs.

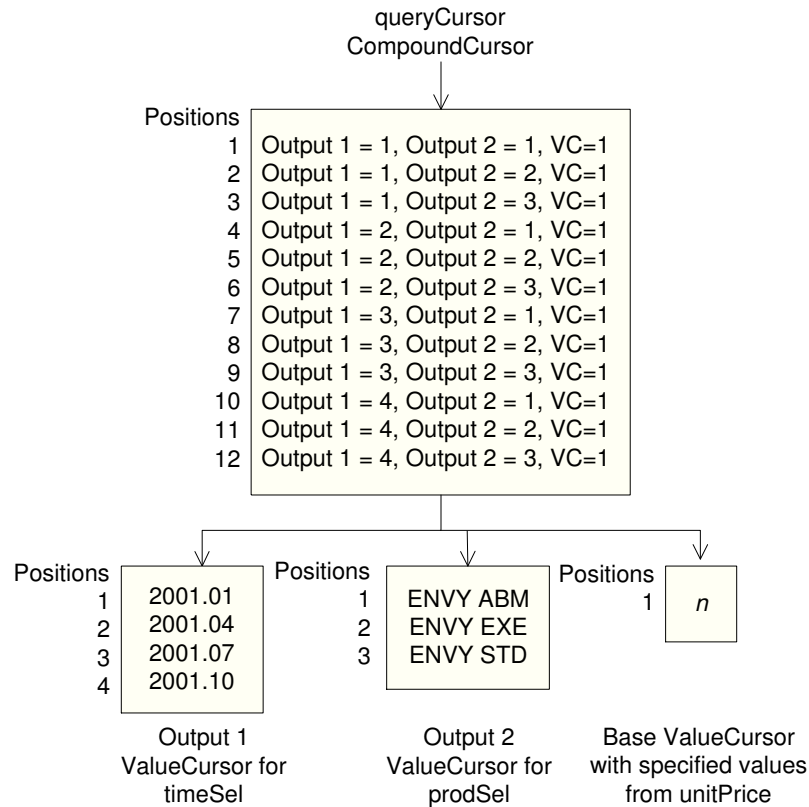

The ValueCursor for queryCursor has only one position because only one value of unitPrice is specified by any one set of values of the outputs. For a query such as querySource, the ValueCursor of the Cursor has only one value, and therefore only one position, at a time for any one position of the root CompoundCursor.

**Figure 8-3 Crosstab Display of queryCursor**

This figure illustrates one possible display of the data from queryCursor. It is a crosstab view with four columns and five rows. In the left column are the month values. In the top row are the product values. In each of the intersecting cells of the crosstab is the price of the product for the month.

Month	Product		
	ENVY ABM	ENVY EXE	ENVY STD
2001.01	3042.22	3223.28	2426.07
2001.04	3026.12	3107.65	2412.42
2001.07	2892.18	3155.91	2505.57
2001.10	2892.18	3105.53	2337.30

A `CompoundCursor` coordinates the positions of the `ValueCursor` objects relative to each other. The current position of the `CompoundCursor` specifies the current positions of the descendent `ValueCursor` objects.

**Example 8-2 Setting the CompoundCursor Position and Getting the Current Values**

This example sets the position of `queryCursor` and then gets the current values and the positions of the child `Cursor` objects.

```
CompoundCursor rootCursor = (CompoundCursor) queryCursor;
ValueCursor baseValueCursor = rootCursor.getValueCursor();
List outputs = rootCursor.getOutputs();
ValueCursor output1 = (ValueCursor) outputs.get(0);
ValueCursor output2 = (ValueCursor) outputs.get(1);
int pos = 5;
rootCursor.setPosition(pos);
println("CompoundCursor position set to " + pos + ".");
println("The current position of the CompoundCursor is = " +
    rootCursor.getPosition() + ".");
println("Output 1 position = " + output1.getPosition() +
    ", value = " + output1.getCurrentValue());
println("Output 2 position = " + output2.getPosition() +
    ", value = " + output2.getCurrentValue());
println("VC position = " + baseValueCursor.getPosition() +
    ", value = " + baseValueCursor.getCurrentValue());
```

This example displays the following:

```
CompoundCursor position set to 5.
The current position of the CompoundCursor is 5.
Output 1 position = 2, value = CALENDAR_YEAR::MONTH::2001.04
Output 2 position = 2, value = PRODUCT_PRIMARY::ITEM::ENVY EXE
VC position = 1, value = 3107.65
```

The positions of `queryCursor` are symmetric in that the result set for `querySource` always has three product values for each time value. The `ValueCursor` for `prodSel`, therefore, always has three positions for each value of the `timeSel` `ValueCursor`. The `timeSel` output `ValueCursor` is slower varying than the `prodSel` `ValueCursor`.

In an asymmetric case, however, the number of positions in a `ValueCursor` is not always the same relative to the slower varying output. For example, if the price of units for product `ENVY ABM` for month `2001.10` were null because that product was no longer being sold by that date, and if null values were suppressed in the query, then `queryCursor` would only have eleven positions. The `ValueCursor` for `prodSel` would only have two positions when the position of the `ValueCursor` for `timeSel` was 4.

[Example 8-3](#) (page 8-11) demonstrates an asymmetric result set that is produced by selecting elements of one dimension based on a comparison of measure values. The example uses the same product and time selections as in [Example 8-1](#) (page 8-3). It uses a `Source` for a measure of product units sold, `units`, that is dimensioned by product, time, sales channels, and customer dimensions. The `chanSel` and `custSel` objects are selections of single values of the dimensions. The example produces a `Source`, `querySource2`, that specifies which of the selected products sold more than one unit for the selected time, channel, and customer values. Because `querySource2` is a derived `Source`, this example commits the current `Transaction`.

The example creates a `Cursor` for `querySource2`, loops through the positions of the `CompoundCursor`, gets the position and current value of the first output `ValueCursor` and the `ValueCursor` of the `CompoundCursor`, and displays the

positions and values of the `ValueCursor` objects. The `getLocalValue` method is a method in the program that extracts the local value from a unique value.

### Example 8-3 Positions in an Asymmetric Query

```
// Create the query
prodSel.join(chanSel).join(custSel).join(timeSel).select(units.gt(1));

// Commit the current Transaction.
try
{ // The DataProvider is dp.
  (dp.getTransactionProvider()).commitCurrentTransaction();
}
catch(Exception e)
{
  output.println("Cannot commit current Transaction " + e);
}

// Create the CursorManager and the Cursor.
CursorManager cursorManager = dp.createCursorManager(querySource2);
Cursor queryCursor2 = cursorManager.createCursor();

CompoundCursor rootCursor = (CompoundCursor) queryCursor2;
ValueCursor baseValueCursor = rootCursor.getValueCursor();
List outputs = rootCursor.getOutputs();
ValueCursor output1 = (ValueCursor) outputs.get(0);

// Get the positions and values and display them.
println("CompoundCursor  Output ValueCursor      ValueCursor");
println(" position      position | value    position | value");
do
{
  println(sp6 + rootCursor.getPosition() + // sp6 is 6 spaces
          sp13 + output1.getPosition() + // sp13 is 13 spaces
          sp7 + getLocalValue(output1.getCurrentString()) + //sp7 is 7 spaces
          sp7 + baseValueCursor.getPosition() +
          sp7 + getLocalValue(baseValueCursor.getCurrentString()));
}
while(queryCursor2.next());
```

The example displays the following:

CompoundCursor	Output ValueCursor	ValueCursor
position	position   value	position   value
1	1   2001.01	1   ENVY ABM
2	1   2001.01	2   ENVY EXE
3	1   2001.01	3   ENVY STD
4	2   2001.04	1   ENVY ABM
5	3   2001.07	1   ENVY ABM
6	3   2001.07	2   ENVY EXE
7	4   2001.10	1   ENVY EXE
8	4   2001.10	2   ENVY STD

Because not every combination of product and time selections has unit sales greater than 1 for the specified channel and customer selections, the number of elements of the `ValueCursor` for the values derived from `prodSel` is not the same for each value of the output `ValueCursor`. For time value 2001.01, all three products have sales greater than one, but for time value 2001.04, only one of the products does. The other two time values, 2001.07 and 2001.10, have two products that meet the criteria. Therefore, the `ValueCursor` for the `CompoundCursor` has three positions for time 2001.01, only one position for time 2001.04, and two positions for times 2001.07 and 2001.10.

### 8.5.3 About the Parent Starting and Ending Positions in a Cursor

To effectively manage the display of the data that you get from a `CompoundCursor`, you sometimes need to know how many faster varying values exist for the current slower varying value. For example, suppose that you are displaying in a crosstab one row of values from an edge of a cube, then you might want to know how many columns to draw in the display for the row.

To determine how many faster varying values exist for the current value of a child `Cursor`, you find the starting and ending positions of that current value in the parent `Cursor`. Subtract the starting position from the ending position and then add 1, as in the following.

```
long span = (cursor.getParentEnd() - cursor.getParentStart()) + 1;
```

The result is the span of the current value of the child `Cursor` in the parent `Cursor`, which tells you how many values of the fastest varying child `Cursor` exist for the current value. Calculating the starting and ending positions is costly in time and computing resources, so you should only specify that you want those calculations performed when your application needs the information.

An Oracle OLAP Java API `Cursor` enables your application to have only the data that it is currently displaying actually present on the client computer. For information on specifying the amount of data for a `Cursor`, see ["About Fetch Sizes \(page 8-13\)"](#).

From the data on the client computer, however, you cannot determine at what position of the parent `Cursor` the current value of a child `Cursor` begins or ends. To get that information, you use the `getParentStart` and `getParentEnd` methods of a `Cursor`.

To specify that you want Oracle OLAP to calculate the starting and ending positions of a value of a child `Cursor` in the parent `Cursor`, call the `setParentStartCalculationSpecified` and `setParentEndCalculationSpecified` methods of the `CursorSpecification` corresponding to the `Cursor`. You can determine whether calculating the starting or ending positions is specified by calling the `isParentStartCalculationSpecified` or `isParentEndCalculationSpecified` methods of the `CursorSpecification`. For an example of specifying these calculations, see [Retrieving Query Results \(page 9-1\)](#).

### 8.5.4 What is the Extent of a Cursor?

The extent of a `Cursor` is the total number of elements it contains relative to any slower varying outputs.

The extent is information that you can use, for example, to display the correct number of columns or correctly-sized scroll bars. The extent, however, can be expensive to calculate. For example, a `Source` that represents a cube might have four outputs. Each output might have hundreds of values. If all null values and zero values of the measure for the sets of outputs are eliminated from the result set, then to calculate the extent of the `CompoundCursor` for the `Source`, Oracle OLAP must traverse the entire result space before it creates the `CompoundCursor`. If you do not specify that you want the extent calculated, then Oracle OLAP only needs to traverse the sets of elements defined by the outputs of the cube as specified by the fetch size of the `Cursor` and as needed by your application.

To specify that you want Oracle OLAP to calculate the extent for a `Cursor`, call the `setExtentCalculationSpecified` method of the `CursorSpecification` corresponding to the `Cursor`. You can determine whether calculating the extent is specified by calling the `isExtentCalculationSpecified` method of the `CursorSpecification`. For an example of specifying the calculation of the extent of a `Cursor`, see [Retrieving Query Results](#) (page 9-1).

## 8.6 About Fetch Sizes

An OLAP Java API `Cursor` represents the entire result set for a `Source`. The `Cursor` is a virtual `Cursor`, however, because it retrieves only a portion of the result set at a time from Oracle OLAP. A `CursorManager` manages a virtual `Cursor` and retrieves results from Oracle OLAP as your application needs them. By managing the virtual `Cursor`, the `CursorManager` relieves your application of a substantial burden.

The amount of data that a `Cursor` retrieves in a single fetch operation is determined by the fetch size specified for the `Cursor`. You specify a fetch size to limit the amount of data your application needs to cache on the local computer and to maximize the efficiency of the fetch by customizing it to meet the needs of your method of displaying the data.

You can also regulate the number of elements that Oracle OLAP returns by using `Parameter` and parameterized `Source` objects in constructing your query. For more information on `Parameter` objects, see [Understanding Source Objects](#) (page 5-1). For examples of using parameterized `Source` objects, see [Making Queries Using Source Methods](#) (page 6-1).

When you create a `CursorManager` for a `Source`, Oracle OLAP specifies a default fetch size on the root `CursorSpecification`. You can change the default fetch size with the `setDefaultFetchSize` method of the root `CursorSpecification`.

You can create two or more `Cursor` objects from the same `CursorManager` and use both `Cursor` objects simultaneously. Rather than having separate data caches, the `Cursor` objects can share the data managed by the `CursorManager`.

An example is an application that displays the results of a query to the user as both a table and a graph. The application creates a `CursorManager` for the `Source`. The application creates two separate `Cursor` objects from the same `CursorManager`, one for a table view and one for a graph view. The two views share the same query and display the same data, just in different formats.

### **Figure 8-4 A Source and Two Cursors for Different Views of the Values**

This figure illustrates the relationship between the `Source`, the `Cursor` objects, and the views.

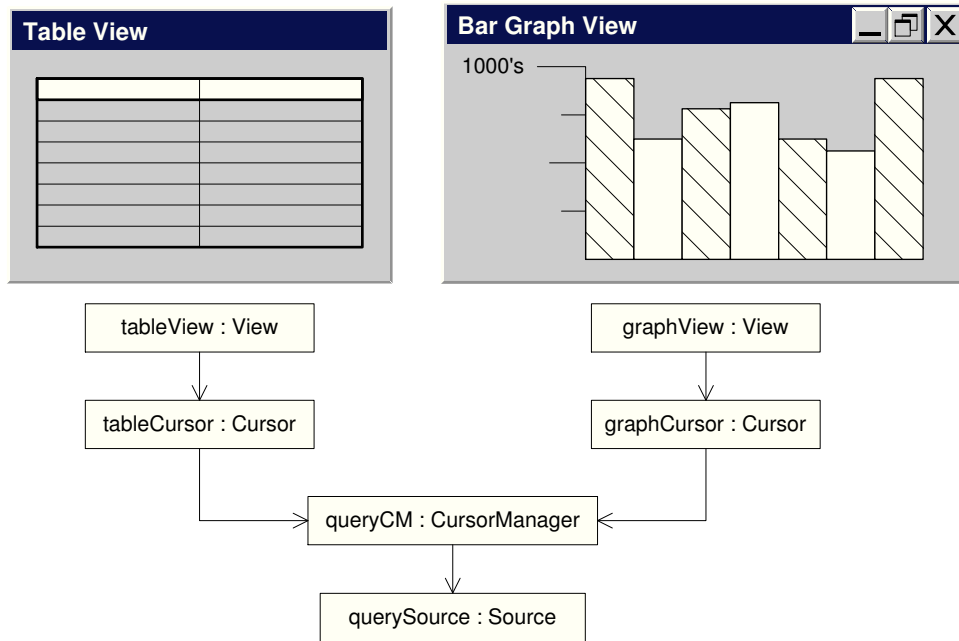



---

## Retrieving Query Results

This chapter describes how to retrieve the results of a query with an Oracle OLAP Java API `Cursor` and how to gain access to those results. This chapter also describes how to customize the behavior of a `Cursor` to fit your method of displaying the results. For information on the class hierarchies of `Cursor` and its related classes, and for information on the `Cursor` concepts of position, fetch size, and extent, see [Understanding Cursor Classes and Concepts](#) (page 8-1).

This chapter includes the following topics:

- [Retrieving the Results of a Query](#) (page 9-1)
- [Navigating a CompoundCursor for Different Displays of Data](#) (page 9-6)
- [Specifying the Behavior of a Cursor](#) (page 9-12)
- [Calculating Extent and Starting and Ending Positions of a Value](#) (page 9-13)
- [Specifying a Fetch Size](#) (page 9-15)

### 9.1 Retrieving the Results of a Query

A query is an OLAP Java API `Source` that specifies the data that you want to retrieve from the data store and any calculations that you want Oracle OLAP to perform on the data. A `Cursor` is the object that retrieves, or *fetches*, the result set specified by a `Source`. Creating a `Cursor` for a `Source` involves the following steps:

1. Get a primary `Source` from an `MdmObject` or create a derived `Source` through operations on a `DataProvider` or a `Source`. For information on getting or creating `Source` objects, see [Understanding Source Objects](#) (page 5-1).
2. If the `Source` is a derived `Source`, then commit the `Transaction` in which you created the `Source`. To commit the `Transaction`, call the `commitCurrentTransaction` method of your `TransactionProvider`. For more information on committing a `Transaction`, see [Using a TransactionProvider](#) (page 7-1). If the `Source` is a primary `Source`, then you do not need to commit the `Transaction`.
3. Create a `CursorManager` by calling a `createCursorManager` method of your `DataProvider` and passing that method the `Source`.
4. Create a `Cursor` by calling the `createCursor` method of the `CursorManager`.

#### **Example 9-1** Creating a Cursor

This example creates a `Cursor` for the derived `Source` named `querySource`. The example uses a `DataProvider` named `dp`. The example creates a `CursorManager` named `cursorMgr` and a `Cursor` named `queryCursor`.

Finally, the example closes the `CursorManager`. When you have finished using the `Cursor`, you should close the `CursorManager` to free resources.

```
CursorManager cursorMngr = dp.createCursorManager(querySource);
Cursor queryCursor = cursorMngr.createCursor();

// Use the Cursor in some way, such as to display the values of it.

cursorMngr.close();
```

### 9.1.1 Getting Values from a Cursor

The `Cursor` interface encapsulates the notion of a *current position* and has methods for moving the current position. The `ValueCursor` and `CompoundCursor` interfaces extend the `Cursor` interface. The Oracle OLAP Java API has implementations of the `ValueCursor` and `CompoundCursor` interfaces. Calling the `createCursor` method of a `CursorManager` returns either a `ValueCursor` or a `CompoundCursor` implementation, depending on the `Source` for which you are creating the `Cursor`.

A `ValueCursor` is returned for a `Source` that has a single set of values. A `ValueCursor` has a value at its current position, and it has methods for getting the value at the current position.

A `CompoundCursor` is created for a `Source` that has more than one set of values, which is a `Source` that has one or more outputs. Each set of values of the `Source` is represented by a child `ValueCursor` of the `CompoundCursor`. A `CompoundCursor` has methods for getting its child `Cursor` objects.

The structure of the `Source` determines the structure of the `Cursor`. A `Source` can have nested outputs, which occurs when one or more of the outputs of the `Source` is itself a `Source` with outputs. If a `Source` has a nested output, then the `CompoundCursor` for that `Source` has a child `CompoundCursor` for that nested output.

The `CompoundCursor` coordinates the positions of the child `Cursor` objects that it contains. The current position of the `CompoundCursor` specifies one set of positions of the child `Cursor` objects.

For an example of a `Source` that has only one level of output values, see [Example 9-4](#) (page 9-4). For an example of a `Source` that has nested output values, see [Example 9-5](#) (page 9-4).

An example of a `Source` that represents a single set of values is one returned by the `getSource` method of an `MdmDimension`, such as an `MdmPrimaryDimension` that represents product values. Creating a `Cursor` for that `Source` returns a `ValueCursor`. Calling the `getCurrentValue` method returns the product value at the current position of that `ValueCursor`.

#### **Example 9-2 Getting a Single Value from a ValueCursor**

This example gets the `Source` from `mdmProdHier`, which is an `MdmLevelHierarchy` that represents product values, and creates a `Cursor` for that `Source`. The example sets the current position to the fifth element of the `ValueCursor` and gets the product value from the `Cursor`. The example then closes the `CursorManager`. In the example, `dp` is the `DataProvider`.

```
Source prodSource = mdmProdHier.getSource();
// Because prodSource is a primary Source, you do not need to
// commit the current Transaction.
CursorManager cursorMngr = dp.createCursorManager(prodSource);
Cursor prodCursor = cursorMngr.createCursor();
```

```

// Cast the Cursor to a ValueCursor.
ValueCursor prodValues = (ValueCursor) prodCursor;
// Set the position to the fifth element of the ValueCursor.
prodValues.setPosition(5);

// Product values are strings. Get the value at the current position.
String value = prodValues.getCurrentString();

// Do something with the value, such as display it.

// Close the CursorManager.
cursorMgr.close();

```

### **Example 9-3 Getting All of the Values from a ValueCursor**

This example uses the same Cursor as [Example 9-2](#) (page 9-2). This example uses a `do...while` loop and the `next` method of the `ValueCursor` to move through the positions of the `ValueCursor`. The `next` method begins at a valid position and returns `true` when an additional position exists in the `Cursor`. It also advances the current position to that next position.

The example sets the position to the first position of the `ValueCursor`. The example loops through the positions and uses the `getCurrentValue` method to get the value at the current position.

```

// prodValues is the ValueCursor for prodSource.
prodValues.setPosition(1);
do
{
    println(prodValues.getCurrentValue);
} while(prodValues.next());

```

The values of the result set represented by a `CompoundCursor` are in the child `ValueCursor` objects of the `CompoundCursor`. To get those values, you must get the child `ValueCursor` objects from the `CompoundCursor`.

An example of a `CompoundCursor` is one that is returned by calling the `createCursor` method of a `CursorManager` for a `Source` that represents the values of a measure as specified by selected values from the dimensions of the measure.

[Example 9-4](#) (page 9-4) uses a `Source`, named `units`, that results from calling the `getSource` method of an `MdmBaseMeasure` that represents the number of units sold. The dimensions of the measure are `MdmPrimaryDimension` objects representing products, customers, times, and channels. This example uses `Source` objects that represent selected values from the default hierarchies of those dimensions. The names of those `Source` objects are `prodSel`, `custSel`, `timeSel`, and `chanSel`. The creation of the `Source` objects representing the measure and the dimension selections is not shown.

[Example 9-4](#) (page 9-4) joins the dimension selections to the measure, which results in a `Source` named `unitsForSelections`. It creates a `CompoundCursor`, named `unitsForSelCursor`, for `unitsForSelections`, and gets the base `ValueCursor` and the outputs from the `CompoundCursor`. Each output is a `ValueCursor`, in this case. The outputs are returned in a `List`. The order of the outputs in the `List` is the inverse of the order in which the outputs were added to the list of outputs by the successive join operations. In the example, `dp` is the `DataProvider`.

**Example 9-4 Getting ValueCursor Objects from a CompoundCursor**

```

Source unitsForSelections = units.join(prodSel)
                               .join(custSel)
                               .join(timeSel)
                               .join(chanSel);
// Commit the current Transaction (code not shown).

// Create a Cursor for unitsForSelections.
CursorManager cursorMngr = dp.createCursorManager(unitsForSelections);
CompoundCursor unitsForSelCursor = (CompoundCursor)
    cursorMngr.createCursor();

// Get the base ValueCursor.
ValueCursor specifiedUnitsVals = unitsForSelCursor.getValueCursor();

// Get the outputs.
List outputs = unitsForSelCursor.getOutputs();
ValueCursor chanSelVals = (ValueCursor) outputs.get(0);
ValueCursor timeSelVals = (ValueCursor) outputs.get(1);
ValueCursor custSelVals = (ValueCursor) outputs.get(2);
ValueCursor prodSelVals = (ValueCursor) outputs.get(3);

// You can now get the values from the ValueCursor objects.
// When you have finished using the Cursor objects, close the CursorManager.
cursorMngr.close();

```

[Example 9-5](#) (page 9-4) uses the same units measure as [Example 9-4](#) (page 9-4), but it joins the dimension selections to the measure differently. [Example 9-5](#) (page 9-4) joins two of the dimension selections together. It then joins the result to the `Source` produced by joining the single dimension selections to the measure. The resulting `Source`, `unitsForSelections`, represents a query has nested outputs, which means it has more than one level of outputs.

The `CompoundCursor` that this example creates for `unitsForSelections` therefore also has nested outputs. The `CompoundCursor` has a child base `ValueCursor` and has as outputs three child `ValueCursor` objects and one child `CompoundCursor`.

[Example 9-5](#) (page 9-4) joins the selection of channel dimension values, `chanSel`, to the selection of customer dimension values, `custSel`. The result is `custByChanSel`, a `Source` that has customer values as the base values and channel values as the values of the output. The example joins to `units` the selections of product and time values, and then joins `custByChanSel`. The resulting query is represented by `unitsForSelections`.

The example commits the current `Transaction` and creates a `CompoundCursor`, named `unitsForSelCursor`, for `unitsForSelections`.

The example gets the base `ValueCursor` and the outputs from the `CompoundCursor`. In the example, `dp` is the `DataProvider`.

**Example 9-5 Getting Values from a CompoundCursor with Nested Outputs**

```

Source custByChanSel = custSel.join(chanSel);
Source unitsForSelections = units.join(prodSel)
                               .join(timeSel)
                               .join(custByChanSel);
// Commit the current Transaction (code not shown).

// Create a Cursor for unitsForSelections.
CursorManager cursorMngr = dp.createCursorManager(unitsForSelections);
Cursor unitsForSelCursor = cursorMngr.createCursor();

```

```

// Send the Cursor to a method that does different operations
// depending on whether the Cursor is a CompoundCursor or a
// ValueCursor.
printCursor(unitsForSelCursor);
cursorMngr.close();
// The remaining code of someMethod is not shown.

// The following code is in from the CursorPrintWriter class.
// The printCursor method has a do..while loop that moves through the positions
// of the Cursor passed to it. At each position, the method prints the number of
// the iteration through the loop and then a colon and a space. The output
// object is a PrintWriter. The method calls the private _printTuple method and
// then prints a new line. A "tuple" is the set of output ValueCursor values
// specified by one position of the parent CompoundCursor. The method prints one
// line for each position of the parent CompoundCursor.
private void printCursor(Cursor rootCursor)
{
    int i = 1;
    do
    {
        print(i++ + ": ");
        _printTuple(rootCursor);
        println();
        flush();
    } while(rootCursor.next());
}

// If the Cursor passed to the _printTuple method is a ValueCursor, then
// the method prints the value at the current position of the ValueCursor.
// If the Cursor passed in is a CompoundCursor, then the method gets the
// outputs of the CompoundCursor and iterates through the outputs,
// recursively calling itself for each output. The method then gets the
// base ValueCursor of the CompoundCursor and calls itself again.
private void _printTuple(Cursor cursor)
{
    if(cursor instanceof CompoundCursor)
    {
        CompoundCursor compoundCursor = (CompoundCursor)cursor;
        // Put an open parenthesis before the value of each output.
        print("(");
        Iterator iterOutputs = compoundCursor.getOutputs().iterator();
        Cursor output = (Cursor)iterOutputs.next();
        _printTuple(output);
        while(iterOutputs.hasNext())
        {
            // Put a comma after the value of each output.
            print(",");
            _printTuple((Cursor)iterOutputs.next());
        }
        // Put a comma after the value of the last output.
        print(",");
        // Get the base ValueCursor.
        _printTuple(compoundCursor.getValueCursor());

        // Put a close parenthesis after the base value to indicate
        // the end of the tuple.
        print(")");
    }
    else if(cursor instanceof ValueCursor)
    {

```

```

        ValueCursor valueCursor = (ValueCursor) cursor;
        if (valueCursor.hasCurrentValue())
            print(valueCursor.getCurrentValue());
        else
            // If this position has a null value.
            print("NA");
    }
}

```

## 9.2 Navigating a CompoundCursor for Different Displays of Data

With the methods of a `CompoundCursor` you can easily move through, or navigate, the `CompoundCursor` structure and get the values from the `ValueCursor` descendents of the `CompoundCursor`. Data from a multidimensional OLAP query is often displayed in a crosstab format, or as a table or a graph.

To display the data for multiple rows and columns, you loop through the positions at different levels of the `CompoundCursor` depending on the needs of your display. For some displays, such as a table, you loop through the positions of the parent `CompoundCursor`. For other displays, such as a crosstab, you loop through the positions of the child `Cursor` objects.

To display the results of a query in a table view, in which each row contains a value from each output `ValueCursor` and from the base `ValueCursor`, you determine the position of the top-level, or root, `CompoundCursor` and then iterate through its positions. [Example 9-6](#) (page 9-6) displays only a portion of the result set at one time. It creates a `Cursor` for a `Source` that represents a query that is based on a measure that has unit cost values. The dimensions of the measure are the product and time dimensions. The creation of the primary `Source` objects and the derived selections of the dimensions is not shown.

The example joins the `Source` objects representing the dimension value selections to the `Source` representing the measure. It commits the current `Transaction` and then creates a `Cursor`, casting it to a `CompoundCursor`. The example sets the position of the `CompoundCursor`, iterates through twelve positions of the `CompoundCursor`, and prints out the values specified at those positions. The `DataProvider` is `dp`.

### **Example 9-6** Navigating for a Table View

```

Source unitPriceByMonth = unitPrice.join(productSel)
                                .join(timeSel);
// Commit the current Transaction (code not shown).

// Create a Cursor for unitPriceByMonth.
CursorManager cursorMngr = dp.createCursorManager(unitPriceByMonth);
CompoundCursor rootCursor = (CompoundCursor) cursorMngr.createCursor();

// Determine a starting position and the number of rows to display.
int start = 7;
int numRows = 12;

println("Month      Product      Unit Price");
println("-----      -");

// Iterate through the specified positions of the root CompoundCursor.
// Assume that the Cursor contains at least (start + numRows) positions.
for(int pos = start; pos < start + numRows; pos++)
{
    // Set the position of the root CompoundCursor.
    rootCursor.setPosition(pos);
    // Print the local values of the output and base ValueCursors.
}

```

```

// The getLocalValue method gets the local value from the unique
// value of a dimension element.
String timeValue = ((ValueCursor)rootCursor.getOutputs().get(0))
    .getCurrentString();
String timeLocVal = getLocalValue(timeValue);
String prodValue = ((ValueCursor)rootCursor.getOutputs().get(1))
    .getCurrentString();
String prodLocVal = getLocalValue(prodValue);
Object price = rootCursor.getValueCursor().getCurrentValue();
println(timeLocVal + " " + prodLocVal + " " + price);
}
cursorMgr.close();

```

If the time selection for the query has eight values, such as the first month of each calendar quarter for the years 2001 and 2002, and the product selection has three values, then the result set of the `unitPriceByMonth` query has twenty-four positions. The example displays the following table, which has the values specified by positions 7 through 18 of the `CompoundCursor`.

Month	Product	Unit Price
2001.07	ENVY ABM	2892.18
2001.07	ENVY EXE	3155.91
2001.07	ENVY STD	2505.57
2001.10	ENVY ABM	2856.86
2001.10	ENVY EXE	3105.53
2001.10	ENVY STD	2337.3
2002.01	ENVY ABM	2896.77
2002.01	ENVY EXE	3008.95
2002.01	ENVY STD	2140.71
2002.04	ENVY ABM	2880.39
2002.04	ENVY EXE	2953.96
2002.04	ENVY STD	2130.88

### **Example 9-7 Navigating for a Crosstab View Without Pages**

This example uses the same query as [Example 9-6](#) (page 9-6). In a crosstab view, the first row is column headings, which are the values from `prodSel` in this example. The output for `prodSel` is the faster varying output because the `prodSel` dimension selection is the last output in the list of outputs that results from the operations that join the measure to the dimension selections. The remaining rows begin with a row heading. The row headings are values from the slower varying output, which is `timeSel`. The remaining positions of the rows, under the column headings, contain the `unitPrice` values specified by the set of the dimension values. To display the results of a query in a crosstab view, you iterate through the positions of the children of the top-level `CompoundCursor`.

The `DataProvider` is `dp`.

```

Source unitPriceByMonth = unitPrice.join(productSel)
    .join(timeSel);
// Commit the current Transaction (code not shown).

// Create a Cursor for unitPriceByMonth.
CursorManager cursorMgr = dp.createCursorManager(unitPriceByMonth);
CompoundCursor rootCursor = (CompoundCursor) cursorMgr.createCursor();

// Get the outputs and the ValueCursor objects.
List outputs = rootCursor.getOutputs();
// The first output has the values of timeSel, the slower varying output.
ValueCursor rowCursor = (ValueCursor) outputs.get(0);

```

```

// The second output has the faster varying values of productSel.
ValueCursor columnCursor = (ValueCursor) outputs.get(1);
// The base ValueCursor has the values from unitPrice.
ValueCursor unitPriceValues = rootCursor.getValueCursor();

// Display the values as a crosstab.
println("          PRODUCT");
println("          -----");
print("Month      ");
do
{
    String value = ((ValueCursor) columnCursor).getCurrentString();
    print(getContext().getLocalValue(value) + "      ");
} while (columnCursor.next());
println("\n-----      -----      -----      -----");

// Reset the column Cursor to its first element.
columnCursor.setPosition(1);

do
{
    // Print the row dimension values.
    String value = ((ValueCursor) rowCursor).getCurrentString();
    print(getContext().getLocalValue(value) + "      ");
    // Loop over columns.
    do
    {
        // Print data value.
        print(unitPriceValues.getCurrentValue() + "      ");
    } while (columnCursor.next());

    println();

    // Reset the column Cursor to its first element.
    columnCursor.setPosition(1);
} while (rowCursor.next());

cursorMgr.close();
    
```

The following is a crosstab view of the values from the result set specified by the `unitPriceByMonth` query. The first line labels the rightmost three columns as having product values. The third line labels the first column as having month values and then labels each of the rightmost three columns with the product value for that column. The remaining lines have the month value in the left column and then have the data values from the units measure for the specified month and product.

	PRODUCT		
	-----	-----	-----
Month	ENVY ABM	ENVY EXE	ENVY STD
-----	-----	-----	-----
2001.01	3042.22	3223.28	2426.07
2001.04	3026.12	3107.65	2412.42
2001.07	2892.18	3155.91	2505.57
2001.10	2856.86	3105.53	2337.30
2002.01	2896.77	3008.95	2140.71
2002.04	2880.39	2953.96	2130.88
2002.07	2865.14	3002.34	2074.56
2002.10	2850.88	2943.96	1921.62



**Example 9-8 Navigating for a Crosstab View With Pages**

This example creates a `Source` that is based on a measure of units sold values. The dimensions of the measure are the customer, product, time, and channel dimensions. The `Source` objects for the dimensions represent selections of the dimension values. The creation of those `Source` objects is not shown.

The query that results from joining the dimension selections to the measure `Source` represents unit sold values as specified by the values of the outputs.

The example creates a `Cursor` for the query and then sends the `Cursor` to the `printAsCrosstab` method, which prints the values from the `Cursor` in a crosstab. That method calls other methods that print page, column, and row values.

The fastest-varying output of the `Cursor` is the selection of products, which has three values (the product items ENVY ABM, ENVY EXE, and ENVY STD). The product values are the column headings of the crosstab. The next fastest-varying output is the selection of customers, which has three values (the customers COMP SERV TOK, COMP WHSE LON, and COMP WHSE SD). Those three values are the row headings. The page dimensions are selections of three time values (the months 2000.01, 2000.02, and 2000.03), and one channel value (DIR, which is the direct sales channel).

The `DataProvider` is `dp`. The `getLocalValue` method gets the local value from a unique dimension value.

```
// In someMethod.
Source unitsForSelections = units.join(prodSel)
                               .join(custSel)
                               .join(timeSel)
                               .join(chanSel);
// Commit the current Transaction (code not shown).

// Create a Cursor for unitsForSelections.
CursorManager cursorMngr = dp.createCursorManager(unitsForSelections);
CompoundCursor unitsForSelCursor = (CompoundCursor) cursorMngr.createCursor();

// Send the Cursor to the printAsCrosstab method.
printAsCrosstab(unitsForSelCursor);

cursorMngr.close();
// The remainder of the code of someMethod is not shown.

private void printAsCrosstab(CompoundCursor rootCursor)
{
    List outputs = rootCursor.getOutputs();
    int nOutputs = outputs.size();

    // Set the initial positions of all outputs.
    Iterator outputIter = outputs.iterator();
    while (outputIter.hasNext())
        ((Cursor) outputIter.next()).setPosition(1);

    // The last output is fastest-varying; it represents columns.
    // The next to last output represents rows.
    // All other outputs are on the page.
    Cursor colCursor = (Cursor) outputs.get(nOutputs - 1);
    Cursor rowCursor = (Cursor) outputs.get(nOutputs - 2);
    ArrayList pageCursors = new ArrayList();
    for (int i = 0 ; i < nOutputs - 2 ; i++)
    {
        pageCursors.add(outputs.get(i));
    }
}
```

```

        // Get the base ValueCursor, which has the data values.
        ValueCursor dataCursor = rootCursor.getValueCursor();

        // Print the pages of the crosstab.
        printPages(pageCursors, 0, rowCursor, colCursor, dataCursor);
    }

    // Prints the pages of a crosstab.
    private void printPages(List pageCursors, int pageIndex, Cursor rowCursor,
        Cursor colCursor, ValueCursor dataCursor)
    {
        // Get a Cursor for this page.
        Cursor pageCursor = (Cursor) pageCursors.get(pageIndex);

        // Loop over the values of this page dimension.
        do
        {
            // If this is the fastest-varying page dimension, print a page.
            if (pageIndex == pageCursors.size() - 1)
            {
                // Print the values of the page dimensions.
                printPageHeadings(pageCursors);

                // Print the column headings.
                printColumnHeadings(colCursor);

                // Print the rows.
                printRows(rowCursor, colCursor, dataCursor);

                // Print a couple of blank lines to delimit pages.
                println();
                println();
            }

            // If this is not the fastest-varying page, recurse to the
            // next fastest-varying dimension.
            else
            {
                printPages(pageCursors, pageIndex + 1, rowCursor, colCursor,
                    dataCursor);
            }
        } while (pageCursor.next());

        // Reset this page dimension Cursor to its first element.
        pageCursor.setPosition(1);
    }

    // Prints the values of the page dimensions on each page.
    private void printPageHeadings(List pageCursors)
    {
        // Print the values of the page dimensions.
        Iterator pageIter = pageCursors.iterator();
        while (pageIter.hasNext())
        {
            String value = ((ValueCursor) pageIter.next()).getCurrentString();
            println(getLocalValue(value));
        }
        println();
    }
}

```

```

// Prints the column headings on each page.
private void printColumnHeadings(Cursor colCursor)
{
    do
    {
        print("\t");
        String value = ((ValueCursor) colCursor).getCurrentString();
        print(getLocalValue(value));
    } while (colCursor.next());
    println();
    colCursor.setPosition(1);
}

// Prints the rows of each page.
private void printRows(Cursor rowCursor, Cursor colCursor,
                      ValueCursor dataCursor)
{
    // Loop over rows.
    do
    {
        // Print row dimension value.
        String value = ((ValueCursor) rowCursor).getCurrentString();
        print(getLocalValue(value));
        print("\t");
        // Loop over columns.
        do
        {
            // Print data value.
            print(dataCursor.getCurrentValue());
            print("\t");
        } while (colCursor.next());
        println();

        // Reset the column Cursor to its first element.
        colCursor.setPosition(1);
    } while (rowCursor.next());

    // Reset the row Cursor to its first element.
    rowCursor.setPosition(1);
}

```

The example displays the following values, formatted as a crosstab. The display has added page, column, and row headings to identify the local values of the dimensions.

```

Channel DIR
Month 2001.01

```

Customer	Product		
	ENVY ABM	ENVY EXE	ENVY STD
COMP WHSE SD	0	0	1
COMP SERV TOK	2	4	2
COMP WHSE LON	1	1	2

```

Channel DIR
Month 2000.02

```

Customer	Product		
	ENVY ABM	ENVY EXE	ENVY STD
COMP WHSE SD	0	0	1
COMP SERV TOK	2	4	2
COMP WHSE LON	1	1	2

COMP WHSE SD	1	1	1	
COMP SERV TOK	5		6	6
COMP WHSE LON	1		2	2

Channel DIR  
Month 2000.03

Customer	Product		
	ENVY ABM	ENVY EXE	ENVY STD
COMP WHSE SD	0	2	2
COMP SERV TOK	2	0	2
COMP WHSE LON	0	2	3

## 9.3 Specifying the Behavior of a Cursor

You can specify the following aspects of the behavior of a `Cursor`.

- The **fetch size** of a `Cursor`, which is the number of elements of the result set that the `Cursor` retrieves during one fetch operation.
- Whether or not Oracle OLAP calculates the **extent** of the `Cursor`. The extent is the total number of positions of the `Cursor`. The extent of a child `Cursor` of a `CompoundCursor` is relative to any of the slower varying outputs of the `CompoundCursor`.
- Whether or not Oracle OLAP calculates the positions in the parent `Cursor` at which the value of a child `Cursor` starts or ends.

To specify the behavior of `Cursor`, you use methods of a `CursorSpecification` that you specify for that `Cursor`. A `CursorSpecification` implements the `CursorInfoSpecification` interface.

You create a `CursorSpecification` for a `Source` by calling the `createCursorInfoSpecification` method of the `DataProvider`. You use methods of the `CursorSpecification` to set the characteristics that you want. You then create a `CursorManager` by calling the appropriate `createCursorManager` method of the `DataProvider`.

---



---

### Note:

Specifying the calculation of the extent or the starting or ending position in a parent `Cursor` of the current value of a child `Cursor` can be a very expensive operation. The calculation can require considerable time and computing resources. You should only specify these calculations when your application needs them.

---



---

For more information on the relationships of `Source`, `Cursor`, and `CursorSpecification` objects or the concepts of fetch size, extent, or `Cursor` positions, see [Understanding Cursor Classes and Concepts](#) (page 8-1).

**Example 9-9** (page 9-13) creates a `Source`, creates a `CompoundCursorSpecification` for a `Source`, and then gets the child `CursorSpecification` objects from the top-level `CompoundCursorSpecification`.

**Example 9-9 Getting CursorSpecification Objects for a Source**

```

Source unitsForSelections = units.join(prodSel)
                               .join(custSel)
                               .join(timeSel)
                               .join(chanSel);
// Commit the current Transaction (code not shown).

// Create a CompoundCursorSpecification for unitsForSelections.
CompoundCursorSpecification rootCursorSpec = (CompoundCursorSpecification)
dp.createCursorInfoSpecification(unitsForSelections);

// Get the ValueCursorSpecification for the base values.
ValueCursorSpecification baseValueSpec =
    rootCursorSpec.getValueCursorSpecification();

// Get the ValueCursorSpecification objects for the outputs.
List outputSpecs = rootCursorSpec.getOutputs();
ValueCursorSpecification chanSelValCSpec =
    (ValueCursorSpecification) outputSpecs.get(0);
ValueCursorSpecification timeSelValCSpec =
    (ValueCursorSpecification) outputSpecs.get(1);
ValueCursorSpecification prodSelValCSpec =
    (ValueCursorSpecification) outputSpecs.get(2);
ValueCursorSpecification custSelValCSpec =
    (ValueCursorSpecification) outputSpecs.get(3);

```

Once you have the `CursorSpecification` objects, you can use their methods to specify the behavior of the `Cursor` objects that correspond to them.

## 9.4 Calculating Extent and Starting and Ending Positions of a Value

To manage the display of the result set retrieved by a `CompoundCursor`, you sometimes need to know the extent of the child `Cursor` components. You might also want to know the position at which the current value of a child `Cursor` starts in the parent `CompoundCursor`. You might want to know the **span** of the current value of a child `Cursor`. The span is the number of positions of the parent `Cursor` that the current value of the child `Cursor` occupies. You can calculate the span by subtracting the starting position of the value from the ending position and subtracting 1.

Before you can get the extent of a `Cursor` or get the starting or ending positions of a value in the parent `Cursor`, you must specify that you want Oracle OLAP to calculate the extent or those positions. To specify the performance of those calculations, you use methods of the `CursorSpecification` for the `Cursor`.

[Example 9-10](#) (page 9-13) specifies calculating the extent of a `Cursor`. The example uses the `CompoundCursorSpecification` from [Example 9-9](#) (page 9-13).

**Example 9-10 Specifying the Calculation of the Extent of a Cursor**

```
rootCursorSpec.setExtentCalculationSpecified(true);
```

You can use methods of a `CursorSpecification` to determine whether the `CursorSpecification` specifies the calculation of the extent of a `Cursor` as in the following example.

```
boolean isSet = rootCursorSpec.isExtentCalculationSpecified();
```

[Example 9-11](#) (page 9-14) specifies calculating the starting and ending positions of the current value of a child `Cursor` in the parent `Cursor`. The example uses the `CompoundCursorSpecification` from [Example 9-9](#) (page 9-13).

**Example 9-11 Specifying the Calculation of Starting and Ending Positions in a Parent**

```
// Get the List of CursorSpecification objects for the outputs.
// Iterate through the list, specifying the calculation of the extent
// for each output CursorSpecification.
Iterator iterOutputSpecs = rootCursorSpec.getOutputs().iterator();
while(iterOutputSpecs.hasNext())
{
    ValueCursorSpecification valCursorSpec =
        (ValueCursorSpecification)iterOutputSpecs.next();
    valCursorSpec.setParentStartCalculationSpecified(true);
    valCursorSpec.setParentEndCalculationSpecified(true);
}
```

You can use methods of a `CursorSpecification` to determine whether the `CursorSpecification` specifies the calculation of the starting or ending positions of the current value of a child `Cursor` in a parent `Cursor`, as in the following example.

```
Iterator iterOutputSpecs = rootCursorSpec.getOutputs().iterator();
ValueCursorSpecification valCursorSpec =
    (ValueCursorSpecification)iterOutputSpecs.next();
while(iterOutputSpecs.hasNext())
{
    if (valCursorSpec.isParentStartCalculationSpecified())
        // Do something.
    if (valCursorSpec.isParentEndCalculationSpecified())
        // Do something.
    valCursorSpec = (ValueCursorSpecification) iterOutputSpecs.next();
}
```

[Example 9-12](#) (page 9-14) determines the span of the positions in a parent `CompoundCursor` of the current value of a child `Cursor` for two of the outputs of the `CompoundCursor`. The example uses the `unitForSelections` `Source` from [Example 9-8](#) (page 9-9).

The example gets the starting and ending positions of the current values of the time and product selections and then calculates the span of those values in the parent `Cursor`. The parent is the root `CompoundCursor`. The `DataProvider` is `dp`.

**Example 9-12 Calculating the Span of the Positions in the Parent of a Value**

```
Source unitsForSelections = units.join(prodSel)
                                .join(custSel)
                                .join(timeSel)
                                .join(chanSel);
// Commit the current Transaction (code not shown).

// Create a CompoundCursorSpecification for unitsForSelections.
CompoundCursorSpecification rootCursorSpec = (CompoundCursorSpecification)
    dp.createCursorInfoSpecification(unitsForSelections);
// Get the CursorSpecification objects for the outputs.
List outputSpecs = rootCursorSpec.getOutputs();
ValueCursorSpecification timeSelValCSpec =
    (ValueCursorSpecification)outputSpecs.get(1); // Output for time.
ValueCursorSpecification prodSelValCSpec =
    (ValueCursorSpecification)outputSpecs.get(3); // Output for product.
```

```

// Specify the calculation of the starting and ending positions.
timeSelValCSpec.setParentStartCalculationSpecified(true);
timeSelValCSpec.setParentEndCalculationSpecified(true);
prodSelValCSpec.setParentStartCalculationSpecified(true);
prodSelValCSpec.setParentEndCalculationSpecified(true);

// Create the CursorManager and the Cursor.
CursorManager cursorMngr =
    dp.createCursorManager(unitsForSelections, 100, rootCursorSpec);
CompoundCursor rootCursor = (CompoundCursor) cursorMngr.createCursor();

// Get the child Cursor objects.
ValueCursor baseValCursor = cursor.getValueCursor();
List outputs = rootCursor.getOutputs();
ValueCursor chanSelVals = (ValueCursor) outputs.get(0);
ValueCursor timeSelVals = (ValueCursor) outputs.get(1);
ValueCursor custSelVals = (ValueCursor) outputs.get(2);
ValueCursor prodSelVals = (ValueCursor) outputs.get(3);

// Set the position of the root CompoundCursor.
rootCursor.setPosition(15);

// Get the values at the current position and determine the span
// of the values of the time and product outputs.
print(chanSelVals.getCurrentValue() + ", ");
print(timeSelVals.getCurrentValue() + ",\n ");
print(custSelVals.getCurrentValue() + ", ");
print(prodSelVals.getCurrentValue() + ", ");
print(baseValCursor.getCurrentValue());
println();

// Determine the span of the values of the two fastest-varying outputs.
long span;
span = (prodSelVals.getParentEnd() - prodSelVals.getParentStart() + 1);
println("\nThe span of " + prodSelVals.getCurrentValue() +
    " at the current position is " + span + ".");
span = (timeSelVals.getParentEnd() - timeSelVals.getParentStart() + 1);
println("The span of " + timeSelVals.getCurrentValue() +
    " at the current position is " + span + ".");
cursorMngr.close();

```

This example displays the following text.

```

CHANNEL_PRIMARY::CHANNEL::DIR, CALENDAR_YEAR::MONTH::2000.02,
    SHIPMENTS::SHIP_TO::COMP SERV TOK, PRODUCT_PRIMARY::ITEM::ENVY STD, 6.0

```

```

The span of PRODUCT_PRIMARY::ITEM::ENVY STD at the current position is 1.
The span of CALENDAR_YEAR::MONTH::2000.02 at the current position is 9.

```

## 9.5 Specifying a Fetch Size

The number of elements of a `Cursor` that Oracle OLAP sends to the client application during one fetch operation depends on the fetch size specified for that `Cursor`. The default fetch size is 100. To change the fetch size, you can set the fetch size on the root `Cursor` for a `Source`.

**Example 9-13 Specifying a Fetch Size**

This example gets the default fetch size from the `CompoundCursorSpecification` from [Example 9-9](#) (page 9-13). The example creates a `Cursor` and sets a different fetch size on it, and then gets the fetch size for the `Cursor`. The `DataProvider` is `dp`.

```
println("The default fetch size is "  
        + rootCursorSpec.getDefaultFetchSize() + ".");  
Source source = rootCursorSpec.getSource();  
CursorManager cursorMngr = dp.createCursorManager(source);  
Cursor rootCursor = cursorMngr.createCursor();  
rootCursor.setFetchSize(10);  
println("The fetch size is now " + rootCursor.getFetchSize() + ".");
```

The example displays the following text.

```
The default fetch size is 100.  
The fetch size is now 10.
```



---

## Creating Dynamic Queries

To create dynamic queries, you use the Oracle OLAP Java API `Template` class and other related classes. The following topics describe these classes and provide examples of implementations of them.

- [About Template Objects](#) (page 10-1)
- [Overview of Template and Related Classes](#) (page 10-2)
- [Designing and Implementing a Template](#) (page 10-4)

### 10.1 About Template Objects

The `Template` class is the basis of a very powerful feature of the Oracle OLAP Java API. You use `Template` objects to create modifiable `Source` objects. With those `Source` objects, you can create dynamic queries that can change in response to end-user selections. `Template` objects also offer a convenient way for you to translate user-interface elements into OLAP Java API operations and objects.

For information on the `Transaction` objects that you use to make changes to the dynamic `Source` and to either save or discard those changes, see [Using a TransactionProvider](#) (page 7-1).

#### 10.1.1 About Creating a Dynamic Source

The main feature of a `Template` is the ability to produce a dynamic `Source`. That ability is based on two of the other objects that a `Template` uses: instances of the `DynamicDefinition` and `MetadataState` classes.

When a `Source` is created, Oracle OLAP automatically associates a `SourceDefinition` with it. The `SourceDefinition` has information about the `Source`. Once created, the `Source` and the associated `SourceDefinition` are associated immutably. The `getSource` method of a `SourceDefinition` returns the `Source` associated with it.

`DynamicDefinition` is a subclass of `SourceDefinition`. A `Template` creates a `DynamicDefinition`, which acts as a proxy for the `SourceDefinition` of the `Source` produced by the `Template`. This means that instead of always getting the same immutably associated `Source`, the `getSource` method of the `DynamicDefinition` gets whatever `Source` is currently produced by the `Template`. The instance of the `DynamicDefinition` does not change even though the `Source` that it gets is different.

The `Source` that a `Template` produces can change because the values, including other `Source` objects, that the `Template` uses to create the `Source` can change. A `Template` stores those values in a `MetadataState`. A `Template` provides methods to get the current state of the `MetadataState`, to get or set a value, and to set the

state. You use those methods to change the data values that the `MetadataState` stores.

You use a `DynamicDefinition` to get the `Source` produced by a `Template`. If your application changes the state of the values that the `Template` uses to create the `Source`, for example, in response to end-user selections, then the application uses the same `DynamicDefinition` to get the `Source` again, even though the new `Source` defines a result set different than the previous `Source`.

The `Source` produced by a `Template` can be the result of a series of `Source` operations that create other `Source` objects, such as a series of selections, sortings, calculations, and joins. You put the code for those operations in the `generateSource` method of a `SourceGenerator` for the `Template`. That method returns the `Source` produced by the `Template`. The operations use the data stored in the `MetadataState`.

You might build an extremely complex query that involves the interactions of dynamic `Source` objects produced by many different `Template` objects. The end result of the query building is a `Source` that defines the entire complex query. If you change the state of any one of the `Template` objects that you used to create the final `Source`, then the final `Source` represents a result set that is different from that of the previous `Source`. You can thereby modify the final query without having to reproduce all of the operations involved in defining the query.

### 10.1.2 About Translating User Interface Elements into OLAP Java API Objects

You design `Template` objects to represent elements of the user interface of an application. Your `Template` objects turn the selections that the end user makes into OLAP Java API query-building operations that produce a `Source`. You then create a `Cursor` to fetch from Oracle OLAP the result set defined by the `Source`. You get the values from the `Cursor` and display them to the end user. When an end user makes changes to the selections, you change the state of the `Template`. You then get the `Source` produced by the `Template`, create a new `Cursor`, get the new values, and display them.

## 10.2 Overview of Template and Related Classes

In the OLAP Java API, several classes work together to produce a dynamic `Source`. In designing a `Template`, you must implement or extend the following:

- The `Template` abstract class
- The `MetadataState` interface
- The `SourceGenerator` interface

Instances of those three classes, plus instances of the `DataProvider` and `DynamicDefinition` classes, work together to produce the `Source` that the `Template` defines.

### 10.2.1 What Is the Relationship Between the Classes That Produce a Dynamic Source?

The classes that produce a dynamic `Source` work together as follows:

- A `Template` has methods that create a `DynamicDefinition` and that get and set the current state of a `MetadataState`. An extension to the `Template` abstract class adds methods that get and set the values of fields on the `MetadataState`.

- The `MetadataState` implementation has fields for storing the data to use in generating the `Source` for the `Template`. When you create a new `Template`, you pass the `MetadataState` to the constructor of the `Template`. When you call the `getSource` method of the `DynamicDefinition`, the `MetadataState` is passed to the `generateSource` method of the `SourceGenerator`.
- The `DataProvider` is used in creating a `Template` and by the `SourceGenerator` in creating new `Source` objects.
- The `SourceGenerator` implementation has a `generateSource` method that uses the current state of the data in the `MetadataState` to produce a `Source` for the `Template`. You pass in the `SourceGenerator` to the `createDynamicDefinition` method of the `Template` to create a `DynamicDefinition`.
- The `DynamicDefinition` has a `getSource` method that gets the `Source` produced by the `SourceGenerator`. The `DynamicDefinition` serves as a proxy for the `SourceDefinition` that is immutably associated with the `Source`.

## 10.2.2 Template Class

You use a `Template` to produce a modifiable `Source`. A `Template` has methods for creating a `DynamicDefinition` and for getting and setting the current state of the `Template`. In extending the `Template` class, you add methods that provide access to the fields on the `MetadataState` for the `Template`. The `Template` creates a `DynamicDefinition` that you use to get the `Source` produced by the `SourceGenerator` for the `Template`.

For an example of a `Template` implementation, see [Example 10-1](#) (page 10-5).

## 10.2.3 MetadataState Interface

An implementation of the `MetadataState` interface stores the current state of the values for a `Template`. A `MetadataState` must include a `clone` method that creates a copy of the current state.

When instantiating a new `Template`, you pass a `MetadataState` to the `Template` constructor. The `Template` has methods for getting and setting the values stored by the `MetadataState`. The `generateSource` method of the `SourceGenerator` for the `Template` uses the `MetadataState` when the method produces a `Source` for the `Template`.

For an example of a `MetadataState` implementation, see [Example 10-2](#) (page 10-8).

## 10.2.4 SourceGenerator Interface

An implementation of `SourceGenerator` must include a `generateSource` method, which produces a `Source` for a `Template`. A `SourceGenerator` must produce only one type of `Source`, such as a `BooleanSource`, a `NumberSource`, or a `StringSource`. In producing the `Source`, the `generateSource` method uses the current state of the data represented by the `MetadataState` for the `Template`.

To get the `Source` produced by the `generateSource` method, you create a `DynamicDefinition` by passing the `SourceGenerator` to the `createDynamicDefinition` method of the `Template`. You then get the `Source` by calling the `getSource` method of the `DynamicDefinition`.

A `Template` can create more than one `DynamicDefinition`, each with a differently implemented `SourceGenerator`. The `generateSource` methods of the different `SourceGenerator` objects use the same data, as defined by the current state of the `MetadataState` for the `Template`, to produce `Source` objects that define different queries.

For an example of a `SourceGenerator` implementation, see [Example 10-3](#) (page 10-8).

### 10.2.5 DynamicDefinition Class

`DynamicDefinition` is a subclass of `SourceDefinition`. You create a `DynamicDefinition` by calling the `createDynamicDefinition` method of a `Template` and passing it a `SourceGenerator`. You get the `Source` produced by the `SourceGenerator` by calling the `getSource` method of the `DynamicDefinition`.

A `DynamicDefinition` created by a `Template` is a proxy for the `SourceDefinition` of the `Source` produced by the `SourceGenerator`. The `SourceDefinition` is immutably associated with the `Source`. If the state of the `Template` changes, then the `Source` produced by the `SourceGenerator` is different. Because the `DynamicDefinition` is a proxy, you use the same `DynamicDefinition` to get the new `Source` even though that `Source` has a different `SourceDefinition`.

The `getCurrent` method of a `DynamicDefinition` returns the `SourceDefinition` immutably associated with the `Source` that the `generateSource` method currently returns. For an example of the use of a `DynamicDefinition`, see [Example 10-4](#) (page 10-10).

## 10.3 Designing and Implementing a Template

The design of a `Template` reflects the query-building elements of the user interface of an application. For example, suppose you want to develop an application that allows the end user to create a query that requests a number of values from the top or bottom of a list of values. The values are from one dimension of a measure. The other dimensions of the measure are limited to single values.

The user interface of your application has a dialog box that allows the end user to do the following:

- Select a radio button that specifies whether the data values should be from the top or bottom of the range of values.
- Select a measure from a drop-down list of measures.
- Select a number from a field. The number specifies the number of data values to display.
- Select one of the dimensions of the measure as the base of the data values to display. For example, if the user selects the product dimension, then the query specifies some number of products from the top or bottom of the list of products. The list is determined by the measure and the selected values of the other dimensions.
- Click a button to bring up a dialog box through which the end user selects the single values for the other dimensions of the selected measure. After selecting the values of the dimensions, the end user clicks an OK button on the second dialog box and returns to the first dialog box.

- Click an OK button to generate the query. The results of the query appear.

To generate a `Source` that represents the query that the end user creates in the first dialog box, you design a `Template` called `TopBottomTemplate`. You also design a second `Template`, called `SingleSelectionTemplate`, to create a `Source` that represents the end user's selections of single values for the dimensions other than the base dimension. The designs of your `Template` objects reflect the user interface elements of the dialog boxes.

In designing the `TopBottomTemplate` and its `MetadataState` and `SourceGenerator`, you do the following:

- Create a class called `TopBottomTemplate` that extends `Template`. To the class, you add methods that get the current state of the `Template`, set the values specified by the user, and then set the current state of the `Template`.
- Create a class called `TopBottomTemplateState` that implements `MetadataState`. You provide fields on the class to store values for the `SourceGenerator` to use in generating the `Source` produced by the `Template`. The values are set by methods of the `TopBottomTemplate`.
- Create a class called `TopBottomTemplateGenerator` that implements `SourceGenerator`. In the `generateSource` method of the class, you provide the operations that create the `Source` specified by the end user's selections.

Using your application, an end user selects units sold as the measure and products as the base dimension in the first dialog box. The end user also selects the Asia Pacific region, the first quarter of 2001, and the direct sales channel as the single values for each of the remaining dimensions.

The query that the end user has created requests the ten products that have the highest total amount of units sold through the direct sales channel to customers in the Asia Pacific region during the calendar year 2001.

For examples of implementations of the `TopBottomTemplate`, `TopBottomTemplateState`, and `TopBottomTemplateGenerator` classes, and an example of an application that uses them, see [Example 10-1](#) (page 10-5), [Example 10-2](#) (page 10-8), [Example 10-3](#) (page 10-8), and [Example 10-4](#) (page 10-10). The `TopBottomTemplateState` and `TopBottomTemplateGenerator` classes are implemented as inner classes of the `TopBottomTemplate` outer class.

### 10.3.1 Implementing the Classes for a Template

The examples in this topic implement the `Template`, `MetadataState`, and `SourceGenerator` classes.

#### **Example 10-1** *Implementing a Template*

This example is an implementation of the `TopBottomTemplate` class.

```
import oracle.olapi.data.source.DataProvider;
import oracle.olapi.data.source.DynamicDefinition;
import oracle.olapi.data.source.Source;
import oracle.olapi.data.source.SourceGenerator;
import oracle.olapi.data.source.Template;
import oracle.olapi.transaction.metadataStateManager.MetadataState;

/**
 * Creates a TopBottomTemplateState, a TopBottomTemplateGenerator,
```

```
* and a DynamicDefinition.
* Gets the current state of the TopBottomTemplateState and the values
* that it stores.
* Sets the data values stored by the TopBottomTemplateState and sets the
* changed state as the current state.
*/
public class TopBottomTemplate extends Template
{
// Constants for specifying the selection of elements from the
// beginning or the end of the result set.
public static final int TOP_BOTTOM_TYPE_TOP = 0;
public static final int TOP_BOTTOM_TYPE_BOTTOM = 1;

// Variable to store the DynamicDefinition.
private DynamicDefinition dynamicDef;

/**
 * Creates a TopBottomTemplate with a default type and number values
 * and the specified base dimension.
 */
public TopBottomTemplate(Source base, DataProvider dataProvider)
{
    super(new TopBottomTemplateState(base, TOP_BOTTOM_TYPE_TOP, 0),
          dataProvider);
    // Create the DynamicDefinition for this Template. Create the
    // TopBottomTemplateGenerator that the DynamicDefinition uses.
    dynamicDef =
        createDynamicDefinition(new TopBottomTemplateGenerator(dataProvider));
}

/**
 * Gets the Source produced by the TopBottomTemplateGenerator
 * from the DynamicDefinition.
 */
public final Source getSource()
{
    return dynamicDef.getSource();
}

/**
 * Gets the Source that is the base of the elements in the result set.
 * Returns null if the state has no base.
 */
public Source getBase()
{
    TopBottomTemplateState state = (TopBottomTemplateState) getCurrentState();
    return state.base;
}

/**
 * Sets a Source as the base.
 */
public void setBase(Source base)
{
    TopBottomTemplateState state = (TopBottomTemplateState) getCurrentState();
    state.base = base;
    setCurrentState(state);
}

/**
 * Gets the Source that specifies the measure and the single
```

```

    * selections from the dimensions other than the base.
    */
public Source getCriterion()
{
    TopBottomTemplateState state = (TopBottomTemplateState) getCurrentState();
    return state.criterion;
}

/**
 * Specifies a Source that defines the measure and the single values
 * selected from the dimensions other than the base.
 * The SingleSelectionTemplate produces such a Source.
 */
public void setCriterion(Source criterion)
{
    TopBottomTemplateState state = (TopBottomTemplateState) getCurrentState();
    state.criterion = criterion;
    setCurrentState(state);
}

/**
 * Gets the type, which is either TOP_BOTTOM_TYPE_TOP or
 * TOP_BOTTOM_TYPE_BOTTOM.
 */
public int getTopBottomType()
{
    TopBottomTemplateState state = (TopBottomTemplateState) getCurrentState();
    return state.topBottomType;
}

/**
 * Sets the type.
 */
public void setTopBottomType(int topBottomType)
{
    if ((topBottomType < TOP_BOTTOM_TYPE_TOP) ||
        (topBottomType > TOP_BOTTOM_TYPE_BOTTOM))
        throw new IllegalArgumentException("InvalidTopBottomType");
    TopBottomTemplateState state = (TopBottomTemplateState) getCurrentState();
    state.topBottomType = topBottomType;
    setCurrentState(state);
}

/**
 * Gets the number of values selected.
 */
public float getN()
{
    TopBottomTemplateState state = (TopBottomTemplateState) getCurrentState();
    return state.N;
}

/**
 * Sets the number of values to select.
 */
public void setN(float N)
{
    TopBottomTemplateState state = (TopBottomTemplateState) getCurrentState();
    state.N = N;
    setCurrentState(state);
}

```

```
    }  
}
```

### **Example 10-2 Implementing a MetadataState**

This example is an implementation of the `TopBottomTemplateState` inner class.

```
/**  
 * Stores data that can be changed by a TopBottomTemplate.  
 * The data is used by a TopBottomTemplateGenerator in producing  
 * a Source for the TopBottomTemplate.  
 */  
private static final class TopBottomTemplateState  
    implements Cloneable, MetadataState  
{  
    public int topBottomType;  
    public float N;  
    public Source criterion;  
    public Source base;  
  
    /**  
     * Creates a TopBottomTemplateState.  
     */  
    public TopBottomTemplateState(Source base, int topBottomType, float N)  
    {  
        this.base = base;  
        this.topBottomType = topBottomType;  
        this.N = N;  
    }  
  
    /**  
     * Creates a copy of this TopBottomTemplateState.  
     */  
    public final Object clone()  
    {  
        try  
        {  
            return super.clone();  
        }  
        catch(CloneNotSupportedException e)  
        {  
            return null;  
        }  
    }  
}
```

### **Example 10-3 Implementing a SourceGenerator**

This example is an implementation of the `TopBottomTemplateGenerator` inner class.

```
/**  
 * Produces a Source for a TopBottomTemplate based on the data  
 * values of a TopBottomTemplateState.  
 */  
private final class TopBottomTemplateGenerator  
    implements SourceGenerator  
{  
    // Store the DataProvider.  
    private DataProvider _dataProvider;  
  
    /**
```



```

    * Creates a TopBottomTemplateGenerator.
    */
public TopBottomTemplateGenerator(DataProvider dataProvider)
{
    _dataProvider = dataProvider;
}

/**
 * Generates a Source for a TopBottomTemplate using the current
 * state of the data values stored by the TopBottomTemplateState.
 */
public Source generateSource(MetadataState state)
{
    TopBottomTemplateState castState = (TopBottomTemplateState) state;
    if (castState.criterion == null)
        throw new NullPointerException("CriterionParameterMissing");
    Source sortedBase = null;

    // Depending on the topBottomType value, select from the base Source
    // the elements specified by the criterion Source and sort the
    // elements in ascending or descending order.
    // For descending order, specify that null values are last.
    // For ascending order, specify that null values are first.

    if (castState.topBottomType == TOP_BOTTOM_TYPE_TOP)
        sortedBase = castState.base.sortDescending(castState.criterion, false);
    else
        sortedBase = castState.base.sortAscending(castState.criterion, true);
    return sortedBase.interval(1, Math.round(castState.N));
}
}

```

### 10.3.2 Implementing an Application That Uses Templates

After you have stored the selections made by the end user in the `MetadataState` for the Template, use the `getSource` method of the `DynamicDefinition` to get the dynamic Source created by the Template. This topic provides an example of an application that uses the `TopBottomTemplate` described in [Example 10-1](#) (page 10-5). For brevity, the code does not contain much exception handling.

The `BaseExample11g` class creates and stores an instance of the `Context11g` class, which has methods that do the following:

- Connect to an Oracle Database instance as the user in the command line arguments.
- Create Cursor objects and displays their values.

[Example 10-4](#) (page 10-10) does the following:

- Gets the `MdmMetadataProvider` and the `MdmRootSchema`.
- Gets the `DataProvider`.
- Gets the `MdmDatabaseSchema` for the user.
- Gets the `MdmCube` that has the COSTS, UNITS and SALES measures. From the cube, the example gets the UNITS and SALES measures and the dimensions associated with the cube.

- Creates a `SingleSelectionTemplate` for selecting single values from some of the dimensions of the measure. For the code of the `SingleSelectionTemplate` class that this example uses, see [SingleSelectionTemplate Class](#) (page B-1).
- Creates a `TopBottomTemplate` and stores selections made by the end user.
- Gets the Source produced by the `TopBottomTemplate`.
- Uses the `Context11g` object to create a `Cursor` for that Source and to display the `Cursor` values.

The complete code for [Example 7-3](#) (page 7-7) includes some of the same code that is in [Example 10-4](#) (page 10-10). The example does not show this code, which extends from the beginning of [Example 10-4](#) (page 10-10) to the following comment in the example:

```
// End of code not shown in
//Example 7-3 (page 7-7).
```

#### **Example 10-4** *Getting the Source Produced by the Template*

```
import oracle.olapi.data.source.DataProvider;
import oracle.olapi.data.source.Source;
import oracle.olapi.examples.*;
import oracle.olapi.metadata.mdm.MdmAttribute;
import oracle.olapi.metadata.mdm.MdmBaseMeasure;
import oracle.olapi.metadata.mdm.MdmCube;
import oracle.olapi.metadata.mdm.MdmDatabaseSchema;
import oracle.olapi.metadata.mdm.MdmDimensionLevel;
import oracle.olapi.metadata.mdm.MdmDimensionMemberInfo;
import oracle.olapi.metadata.mdm.MdmHierarchyLevel;
import oracle.olapi.metadata.mdm.MdmLevelHierarchy;
import oracle.olapi.metadata.mdm.MdmMetadataProvider;
import oracle.olapi.metadata.mdm.MdmPrimaryDimension;
import oracle.olapi.metadata.mdm.MdmRootSchema;

/**
 * Creates a query that specifies a number of elements from the top
 * or bottom of a selection of dimension members, creates a Cursor
 * for the query, and displays the values of the Cursor.
 * The selected dimension members are those that have measure values
 * that are specified by selected members of the other dimensions of
 * the measure.
 */
public class TopBottomTest extends BaseExample11g
{
    /**
     * Gets the MdmMetadataProvider, the DataProvider, the MdmRootSchema, and the
     * MdmDatabaseSchema for the current user.
     * Gets the UNITS_CUBE_AWJ MdmCube.
     * From the cube, gets the MdmBaseMeasure objects for the UNITS and SALES
     * measures and the MdmPrimaryDimension objects that dimension them.
     * Gets a hierarchy of the PRODUCT_AWJ dimension and the leaf level of the
     * dimension.
     * Gets the short description attribute of the dimension.
     * Creates a SingleSelectionTemplate and adds selections to it.
     * Creates a TopBottomTemplate and sets the properties of it.
     * Gets the Source produced by the TopBottomTemplate, creates a Cursor
     * for it, and displays the values of the Cursor.
     * Changes the state of the SingleSelectionTemplate and the
     * TopBottomTemplate, creates a new Cursor for the Source produced by the
```

```

* TopBottomTemplate, and displays the values of that Cursor.
*/
public void run() throws Exception
{
    // Get the MdmMetadataProvider from the superclass.
    MdmMetadataProvider metadataProvider = getMdmMetadataProvider();
    // Get the DataProvider from the Context11g object of the superclass.
    DataProvider dp = getContext().getDataProvider();

    // Get the MdmRootSchema and the MdmDatabaseSchema for the user.
    MdmRootSchema mdmRootSchema =
        (MdmRootSchema)metadataProvider.getRootSchema();
    MdmDatabaseSchema mdmDBSchema =
        mdmRootSchema.getDatabaseSchema(getContext().getUser());

    MdmCube unitsCube =
        (MdmCube)mdmDBSchema.getTopLevelObject("UNITS_CUBE_AWJ");
    MdmBaseMeasure mdmUnits = unitsCube.findOrCreateBaseMeasure("UNITS");
    MdmBaseMeasure mdmSales = unitsCube.findOrCreateBaseMeasure("SALES");

    // Get the Source objects for the measures.
    Source units = mdmUnits.getSource();
    Source sales = mdmSales.getSource();

    // Get the MdmPrimaryDimension objects for the dimensions of the cube.
    List<MdmPrimaryDimension> cubeDims = unitsCube.getDimensions();
    MdmPrimaryDimension mdmTimeDim = null;
    MdmPrimaryDimension mdmProdDim = null;
    MdmPrimaryDimension mdmCustDim = null;
    MdmPrimaryDimension mdmChanDim = null;

    for(MdmPrimaryDimension mdmPrimDim : cubeDims)
    {
        if (mdmPrimDim.getName().startsWith("TIME"))
            mdmTimeDim = mdmPrimDim;
        else if (mdmPrimDim.getName().startsWith("PROD"))
            mdmProdDim = mdmPrimDim;
        else if (mdmPrimDim.getName().startsWith("CUST"))
            mdmCustDim = mdmPrimDim;
        else if (mdmPrimDim.getName().startsWith("CHAN"))
            mdmChanDim = mdmPrimDim;
    }

    // Get the hierarchy of the PRODUCT_AWJ dimension.
    MdmLevelHierarchy mdmProdHier =
        mdmProdDim.findOrCreateLevelHierarchy("PRODUCT_PRIMARY");

    // Get the detail dimension level of the PRODUCT_AWJ dimension.
    MdmDimensionLevel mdmItemDimLevel =
        mdmProdDim.findOrCreateDimensionLevel("ITEM");
    // Get the hierarchy level of the dimension level.
    MdmHierarchyLevel mdmItemHierLevel =
        mdmProdHier.findOrCreateHierarchyLevel(mdmItemDimLevel);
    // Get the Source for the hierarchy level.
    Source itemLevel = mdmItemHierLevel.getSource();

    // Get the short description attribute for the PRODUCT_AWJ dimension and
    // the Source for the attribute.
    MdmAttribute mdmProdShortDescrAttr =
        mdmProdDim.getShortValueDescriptionAttribute();

```

```
Source prodShortDescrAttr = mdmProdShortDescrAttr.getSource();

// Create a SingleSelectionTemplate to produce a Source that
// represents the measure values specified by single members of each of
// the dimensions of the measure other than the base dimension.
SingleSelectionTemplate singleSelections =
    new SingleSelectionTemplate(units, dp);

// Create MdmDimensionMemberInfo objects for single members of the
// other dimensions of the measure.
MdmDimensionMemberInfo timeMemInfo =
    new MdmDimensionMemberInfo(mdmTimeDim, "CALENDAR_YEAR::YEAR::CY2001");
MdmDimensionMemberInfo custMemInfo =
    new MdmDimensionMemberInfo(mdmCustDim, "SHIPMENTS::REGION::APAC");
MdmDimensionMemberInfo chanMemInfo =
    new MdmDimensionMemberInfo(mdmChanDim, "CHANNEL_PRIMARY::CHANNEL::DIR");

// Add the dimension member information objects to the
// SingleSelectionTemplate.
singleSelections.addDimMemberInfo(custMemInfo);
singleSelections.addDimMemberInfo(chanMemInfo);
singleSelections.addDimMemberInfo(timeMemInfo);

// Create a TopBottomTemplate specifying, as the base, the Source for a
// a level of a hierarchy.
TopBottomTemplate topNBottom = new TopBottomTemplate(itemLevel, dp);

// Specify whether to retrieve the elements from the beginning (top) or the
// end (bottom) of the selected elements of the base dimension.
topNBottom.setTopBottomType(TopBottomTemplate.TOP_BOTTOM_TYPE_TOP);

// Set the number of elements of the base dimension to retrieve.
topNBottom.setN(10);
// Get the Source produced by the SingleSelectionTemplate and specify it as
// the criterion object.
topNBottom.setCriterion(singleSelections.getSource());

// End of code not shown in
// Example 7-3 (page 7-7).

// Display a description of the result.
String resultDescription = " products with the most units sold \nfor";
displayResultDescr(singleSelections, topNBottom, resultDescription);

// Get the Source produced by the TopBottomTemplate.
Source result = topNBottom.getSource();

// Join the Source produced by the TopBottomTemplate with the short
// value descriptions. Use the joinHidden method so that the
// dimension member values do not appear in the result.
Source result = prodShortDescrAttr.joinHidden(topNBottomResult);

// Commit the current transaction.
getContext().commit(); // Method of Context11g.

// Create a Cursor for the result and display the values of the Cursor.
getContext().displayTopBottomResult(result);

// Change a dimension member selection of the SingleSelectionTemplate.
timeMemInfo.setUniqueValue("CALENDAR_YEAR::YEAR::CY2000");
singleSelections.changeSelection(timeMemInfo);
```

```

// Change the number of elements selected and the type of selection.
topNBottom.setN(5);
topNBottom.setTopBottomType(TopBottomTemplate.TOP_BOTTOM_TYPE_BOTTOM);

// Join the Source produced by the TopBottomTemplate to the short
// description attribute.
result = prodShortDescrAttr.joinHidden(topNBottomResult);

// Commit the current transaction.
getContext().commit();

// Display a description of the result.
resultDescription = " products with the fewest units sold \nfor";
displayResultDescr(singleSelections, topNBottom, resultDescription);

// Create a new Cursor for the Source produced by the TopBottomTemplate
// and display the Cursor values.
getContext().displayTopBottomResult(result);

// Now change the measure to SALES, and get the top and bottom products by
// SALES.
singleSelections.setMeasure(sales);
// Change the number of elements selected.
topNBottom.setN(7);
// Change the type of selection back to the top.
topNBottom.setTopBottomType(TopBottomTemplate.TOP_BOTTOM_TYPE_TOP);

resultDescription = " products with the highest sales amounts \nfor";
displayResultDescr(singleSelections, topNBottom, resultDescription);

topNBottomResult = topNBottom.getSource();
result = prodShortDescrAttr.joinHidden(topNBottomResult);

// Commit the current transaction.
getContext().commit();
getContext().displayTopBottomResult(result);

// Change the type of selection back to the bottom.
topNBottom.setTopBottomType(TopBottomTemplate.TOP_BOTTOM_TYPE_BOTTOM);

resultDescription = " products with the lowest sales amounts \nfor";
displayResultDescr(singleSelections, topNBottom, resultDescription);

topNBottomResult = topNBottom.getSource();
result = prodShortDescrAttr.joinHidden(topNBottomResult);

// Commit the current transaction.
getContext().commit();
getContext().displayTopBottomResult(result);
}

/**
 * Displays a description of the results of the query.
 *
 * @param singleSelections The SingleSelectionsTemplate used by the query.
 *
 * @param topNBottom The TopBottomTemplate used by the query.
 *
 * @param resultDescr A String that contains a description of the query.

```

```

        */
private void displayResultDescr(SingleSelectionTemplate singleSelections,
                               TopBottomTemplate topNBottom,
                               String resultDescr)
{
    DataProvider dp = getContext().getDataProvider();

    // Get the short descriptions of the dimension members of the
    // SingleSelectionTemplate.
    StringBuffer shortDescrsForMemberVals =
        singleSelections.getMemberShortDescrs(dp);

    // Display the number of dimension members selected, the result description,
    // and the short descriptions of the single selection dimension members.
    println("\nThe " + Math.round(topNBottom.getN()) + resultDescr
           + shortDescrsForMemberVals + " are:\n");
}

/**
 * Runs the TopBottomTest application.
 *
 * @param args An array of String objects that provides the arguments
 *             required to connect to an Oracle Database instance, as
 *             specified in the Context11g class.
 */
public static void main(String[] args)
{
    new TopBottomTest().execute(args);
}
}

```

The `TopBottomTest` program produces the following output.

The 10 products with the most units sold  
for Asia Pacific, Direct Sales, 2001 are:

1. Mouse Pad
2. Unix/Windows 1-user pack
3. Deluxe Mouse
4. Laptop carrying case
5. 56Kbps V.90 Type II Modem
6. 56Kbps V.92 Type II Fax/Modem
7. Keyboard Wrist Rest
8. Internal - DVD-RW - 6X
9. O/S Documentation Set - English
10. External - DVD-RW - 8X

The 5 products with the fewest units sold  
for Asia Pacific, Direct Sales, 2000 are:

1. Envoy External Keyboard
2. O/S Documentation Set - Italian
3. External 48X CD-ROM
4. O/S Documentation Set - Spanish
5. Internal 48X CD-ROM USB

The 7 products with the highest sales amounts  
for Asia Pacific, Direct Sales, 2000 are:

1. Sentinel Financial
2. Sentinel Standard

3. Envoy Executive
4. Sentinel Multimedia
5. Envoy Standard
6. Envoy Ambassador
7. 56Kbps V.90 Type II Modem

The 7 products with the lowest sales amounts for Asia Pacific, Direct Sales, 2000 are:

1. Envoy External Keyboard
2. Keyboard Wrist Rest
3. Mouse Pad
4. O/S Documentation Set - Italian
5. O/S Documentation Set - Spanish
6. Standard Mouse
7. O/S Documentation Set - French





---

# Setting Up the Development Environment

This appendix describes the development environment for creating applications that use the OLAP Java API.

This appendix includes the following topics:

- [Overview](#) (page A-1)
- [Required Class Libraries](#) (page A-1)
- [Obtaining the Class Libraries](#) (page A-2)

## A.1 Overview

The OLAP Java API client software is a set of Java packages containing classes that implement a Java programming interface to Oracle OLAP. An Oracle Database with the OLAP option provides the OLAP Java API and other required class libraries as Java archive (JAR) files. As an application developer, you must copy the required JAR files to the computer on which you develop your Java application, or otherwise make them accessible to your development environment.

When a Java application calls methods of OLAP Java API objects, it uses the OLAP Java API client software to communicate with Oracle OLAP, which resides within an Oracle Database instance. The communication between the OLAP Java API client software and Oracle OLAP is provided through the Java Database Connectivity (JDBC) API, which is a standard Java interface for connecting to relational databases. Another required JAR file provides support for importing and exporting OLAP Java API metadata objects XML.

To use the OLAP Java API classes as you develop your application, import them into your Java code. When you deliver your application to users, include the OLAP Java API classes with the application. You must also ensure that users can access JDBC.

To develop an OLAP Java API application, you must have the Java Development Kit (JDK), such as one in Oracle JDeveloper. Users must have a Java Runtime Environment (JRE) whose version number is compatible with the JDK that you used for development.

## A.2 Required Class Libraries

Your application development environment must have the following files:

- The `olap_api.jar` file, which contains the OLAP Java API class libraries.
- The `ojdbc6.jar` file, which is an Oracle JDBC (Java Database Connectivity) library that contains classes required to connect to an Oracle Database instance. The Oracle installation includes the JDBC file. You must use that JDBC file and not one from another Oracle product or from a product from another vendor.

- The `xmlparserv2.jar` file, which contains classes that provide XML parsing support.
- The Java Development Kit (JDK) version 1.6. The Oracle Database installation does not provide the JDK. If you are using Oracle JDeveloper as your development environment, then the JDK is already installed on your computer. However, ensure that you are using the correct version of the JDK in JDeveloper. For information about obtaining and using some other JDK, see the Oracle Technology Network Java website at <http://www.oracle.com/technetwork/java/index.html>.

## A.3 Obtaining the Class Libraries

[Table A-1](#) (page A-2) lists the OLAP Java API and other JAR files that you must include in your application development environment. The table includes the locations of the files under the directory identified by the `ORACLE_HOME` environment variable on the system on which the Oracle Database is installed. You can copy these files to your application development computer, or otherwise include them in your development environment.

**Table A-1 Required Class Libraries and Their Locations in the Oracle Installation**

Class Library jar File	Location under ORACLE_HOME
<code>olap_api.jar</code>	<code>/olap/api/lib</code>
<code>ojdbc6.jar</code>	<code>/jdbc/lib</code>
<code>xmlparserv2.jar</code>	<code>/lib</code>

---

## SingleSelectionTemplate Class

This appendix contains the code for the `SingleSelectionTemplate` class. This class is used by the examples in [Using a TransactionProvider](#) (page 7-1), and [Creating Dynamic Queries](#) (page 10-1).

### B.1 Code for the SingleSelectionTemplate Class

The following is the `SingleSelectionTemplate.java` class.

```
import java.util.ArrayList;
import java.util.Collections;
import java.util.Iterator;
import java.util.List;
import oracle.olapi.data.cursor.CursorManager;
import oracle.olapi.data.cursor.ValueCursor;
import oracle.olapi.data.source.DataProvider;
import oracle.olapi.data.source.DynamicDefinition;
import oracle.olapi.data.source.Source;
import oracle.olapi.data.source.StringSource;
import oracle.olapi.data.source.SourceGenerator;
import oracle.olapi.data.source.Template;
import oracle.olapi.metadata.mdm.MdmAttribute;
import oracle.olapi.metadata.mdm.MdmDimensionMemberInfo;
import oracle.olapi.metadata.mdm.MdmHierarchy;
import oracle.olapi.metadata.mdm.MdmPrimaryDimension;
import oracle.olapi.transaction.TransactionProvider;
import oracle.olapi.transaction.NotCommittableException;
import oracle.olapi.transaction.metadataStateManager.MetadataState;

/**
 * A Template that joins Source objects for selected members of
 * dimension hierarchies to a Source for a measure.
 */
public class SingleSelectionTemplate extends Template
{
    // Variable to store the DynamicDefinition.
    private DynamicDefinition dynamicDef;

    /**
     * Creates a SingleSelectionTemplate.
     */
    public SingleSelectionTemplate(Source measure, DataProvider dataProvider)
    {
        super(new SingleSelectionTemplateState(measure), dataProvider);
        dynamicDef = createDynamicDefinition(
            new SingleSelectionTemplateGenerator(dataProvider));
    }

    /**
     * Gets the Source produced by the SingleSelectionTemplateGenerator

```

```
    * from the DynamicDefinition.
    */
    public final Source getSource()
    {
        return dynamicDef.getSource();
    }

    /**
     * Gets the Source for the measure stored by the SingleSelectionTemplateState.
     */
    public Source getMeasure()
    {
        SingleSelectionTemplateState state =
            (SingleSelectionTemplateState)getCurrentState();
        return state.measure;
    }

    /**
     * Specifies the Source for the measure stored by the
     * SingleSelectionTemplateState.
     */
    public void setMeasure(Source measure)
    {
        SingleSelectionTemplateState state =
            (SingleSelectionTemplateState)getCurrentState();
        state.measure = measure;
        setCurrentState(state);
    }

    /**
     * Gets the List of MdmDimensionMemberInfo objects for the selected members
     * of the dimensions.
     */
    public List getDimMemberInfos()
    {
        SingleSelectionTemplateState state =
            (SingleSelectionTemplateState)getCurrentState();
        return Collections.unmodifiableList(state.dimMemberInfos);
    }

    /**
     * Adds an MdmDimensionMemberInfo to the List of
     * MdmDimensionMemberInfo objects.
     */
    public void addDimMemberInfo(MdmDimensionMemberInfo mdmDimMemberInfo)
    {
        SingleSelectionTemplateState state =
            (SingleSelectionTemplateState)getCurrentState();
        state.dimMemberInfos.add(mdmDimMemberInfo);
        setCurrentState(state);
    }

    /**
     * Changes the member specified for a dimension.
     */
    public void changeSelection(MdmDimensionMemberInfo mdmDimMemberInfo)
    {
        SingleSelectionTemplateState state =
            (SingleSelectionTemplateState)getCurrentState();
        int i = 0;
```

```

Iterator dimMemberInfosItr = state.dimMemberInfos.iterator();
while (dimMemberInfosItr.hasNext())
{
    MdmDimensionMemberInfo mdmDimMemberInfoInList =
        (MdmDimensionMemberInfo)dimMemberInfosItr.next();
    MdmPrimaryDimension mdmPrimDim1 = mdmDimMemberInfo.getPrimaryDimension();
    MdmPrimaryDimension mdmPrimDim2 =
        mdmDimMemberInfoInList.getPrimaryDimension();
    //String value = (String)valuesItr.next();
    if (mdmPrimDim1.getName().equals(mdmPrimDim2.getName()))
    {
        state.dimMemberInfos.remove(i);
        state.dimMemberInfos.add(i, mdmDimMemberInfo);
        break;
    }
    i++;
}

setCurrentState(state);
}

/**
 * Gets the short value description of the each of the dimension members
 * specified by the list of MdmDimensionMemberInfo objects and returns
 * the descriptions in a StringBuffer.
 */
public StringBuffer getMemberShortDescrs(DataProvider dp)
{
    boolean firsttime = true;

    List mdmDimMemInfoList = getDimMemberInfos();

    StringBuffer shortDescrForMemberVals = new StringBuffer(" ");
    Iterator mdmDimMemInfoListItr = mdmDimMemInfoList.iterator();

    while(mdmDimMemInfoListItr.hasNext())
    {
        MdmDimensionMemberInfo mdmDimMemInfo =
            (MdmDimensionMemberInfo)mdmDimMemInfoListItr.next();
        MdmPrimaryDimension mdmPrimDim = mdmDimMemInfo.getPrimaryDimension();
        MdmAttribute mdmShortDescrAttr =
            mdmPrimDim.getShortValueDescriptionAttribute();
        Source shortDescrAttr = mdmShortDescrAttr.getSource();
        MdmHierarchy mdmHier = mdmDimMemInfo.getHierarchy();
        StringSource hierSrc = (StringSource) mdmHier.getSource();
        Source memberSel = hierSrc.selectValue(mdmDimMemInfo.getUniqueValue());
        Source shortDescrForMember = shortDescrAttr.joinHidden(memberSel);

        // Commit the current transaction.
        try
        {
            (dp.getTransactionProvider()).commitCurrentTransaction();
        }
        catch (Exception ex)
        {
            println("Could not commit the Transaction. " + ex);
        }
    }

    CursorManager cmngr = dp.createCursorManager(shortDescrForMember);
    ValueCursor valCursor = (ValueCursor)cmngr.createCursor();

```

```
        String shortDescrForMemberVal = valCursor.getCurrentString();

        if(firsttime)
        {
            shortDescrForMemberVals.append(shortDescrForMemberVal);
            firsttime = false;
        }
        else
        {
            shortDescrForMemberVals.append(", " + shortDescrForMemberVal);
        }
    }

    return shortDescrForMemberVals;
}

/**
 * Inner class that implements the MetadataState object for this Template.
 * Stores data that can be changed by its SingleSelectionTemplate.
 * The data is used by a SingleSelectionTemplateGenerator in producing
 * a Source for the SingleSelectionTemplate.
 */
private static class SingleSelectionTemplateState
    implements MetadataState
{
    public Source measure;
    public ArrayList dimMemberInfos;

    /**
     * Creates a SingleSelectionTemplateState.
     */
    public SingleSelectionTemplateState(Source measure)
    {
        this(measure, new ArrayList());
    }

    private SingleSelectionTemplateState(Source measure,
                                         ArrayList dimMemberInfos)
    {
        this.measure = measure;
        this.dimMemberInfos = dimMemberInfos;
    }

    public Object clone()
    {
        return new SingleSelectionTemplateState(measure,
                                                (ArrayList)
                                                dimMemberInfos.clone());
    }
}

/**
 * Inner class that implements the SourceGenerator object for this Template.
 * Produces a Source based on the data values of a SingleSelectionTemplate.
 */
private static final class SingleSelectionTemplateGenerator
    implements SourceGenerator
{
    DataProvider dp = null;
}
```

```
/**
 * Creates a SingleSelectionTemplateGenerator.
 */
public SingleSelectionTemplateGenerator(DataProvider dataProvider)
{
    dp = dataProvider;
}

/**
 * Generates a Source for the SingleSelectionTemplate.
 */
public Source generateSource(MetadataState state)
{
    SingleSelectionTemplateState castState =
        (SingleSelectionTemplateState)state;
    Source result = castState.measure;

    Iterator dimMemberInfosItr = castState.dimMemberInfos.iterator();
    while (dimMemberInfosItr.hasNext())
    {
        MdmDimensionMemberInfo mdmDimMemInfo =
            (MdmDimensionMemberInfo)dimMemberInfosItr.next();
        MdmHierarchy mdmHier = mdmDimMemInfo.getHierarchy();
        StringSource hierSrc = (StringSource) mdmHier.getSource();
        Source memberSel = hierSrc.selectValue(mdmDimMemInfo.getUniqueValue());
        // Join the Source objects for the selected dimension members
        // to the measure.
        result = result.joinHidden(memberSel);
    }
    return result;
}
}
```





## A

---

access to metadata objects  
restricting, [2-14](#)

addObjectClassification method, [2-8](#)

aggregate levels of a hierarchy, [2-21](#)

AggregationCommand objects  
example of creating, [4-8](#)

alias method  
description, [6-1](#)  
example of, [6-3](#)

ALL metadata reader mode, [2-5](#)

Analytic Workspace Manager, [1-6](#)

analytic workspaces  
building, [1-5](#)  
building, example of, [4-11](#)  
creating, [4-2](#)  
sample, [1-7](#)

ancestors attribute  
example of getting, [6-11](#)  
method for getting, [2-21](#)

appendValues method  
example of, [6-4](#)

applications  
requirements for developing, [A-1](#)  
typical tasks performed by, [1-8](#)

ascending  
comparison rules in a join operation, [5-7](#)

asymmetric result set, Cursor positions in an, [8-10](#)

at method  
example of, [6-17](#)

AttributeMap objects  
creating, [4-3](#)

attributes  
as dimensional data objects, [1-5](#)  
creating, [4-7](#)  
creating an index for, [2-26](#)  
grouping, [2-26](#)  
mapping, [4-8](#)  
mapping, example of, [4-3](#)  
multilingual, [2-26](#)  
prefixes for in materialized views, [2-28](#)  
represented by MdmAttribute objects, [2-23](#)

attributes (*continued*)  
specifying language for, [2-26](#)  
specifying target dimension for, [2-25](#)  
unique key, [2-28](#)

AW objects  
creating, [4-2](#)  
naming, [2-4](#)

AWCubeOrganization class, [2-16](#)

AWCubeOrganization objects  
example of creating, [4-8](#)

AWPrimaryDimensionOrganization objects  
creating, [4-3](#)

## B

---

base Source  
definition, [5-4](#), [6-1](#)  
of a join operation, [5-6](#)

BaseExample11g.java example program, [1-7](#)

BaseMetadataObject class, [2-3](#)

basic Source methods, [6-1](#)

bind variables  
in XML templates, [2-12](#)

Buildable interface, [2-20](#)

building analytic workspaces  
example of, [4-11](#)

BuildItem objects  
creating, [4-11](#)

BuildProcess objects  
creating, [4-11](#)

## C

---

Cartesian product  
result of joining unrelated Source objects, [5-6](#)

class libraries  
obtaining, [A-2](#)

classifying metadata objects, [2-8](#)

ColumnExpression objects  
creating, [4-3](#)

committing transactions, [4-10](#)

comparison parameter  
of the join method, [5-7](#)

COMPARISON\_RULE\_ASCENDING  
     example of, [6-8](#), [6-19](#)  
 COMPARISON\_RULE\_ASCENDING\_NULLS\_FIRST  
     example of, [6-8](#)  
 COMPARISON\_RULE\_DESCENDING  
     example of, [6-5](#)  
 COMPARISON\_RULE\_DESCENDING\_NULLS\_FIRST  
     example of, [6-8](#)  
 COMPARISON\_RULE\_REMOVE  
     description, [5-7](#)  
     example of, [5-10](#), [6-7](#), [6-12](#)  
 COMPARISON\_RULE\_SELECT  
     description, [5-7](#)  
     example of, [5-9](#), [5-10](#), [5-16](#)  
 comparisonRule parameter  
     of a join method, [5-7](#)  
 CompoundCursor objects  
     getting children of, example, [9-3](#)  
     navigating for a crosstab view, example, [9-7](#), [9-9](#)  
     navigating for a table view, example, [9-6](#)  
     positions of, [8-8](#)  
 connections  
     closing, [3-3](#)  
     creating, [3-2](#)  
     prerequisites for, [3-1](#)  
 consistent cube, [2-17](#)  
 ConsistentSolveCommand objects  
     contained by a ConsistentSolveSpecification, [2-16](#)  
     example of creating, [4-8](#)  
 ConsistentSolveSpecification objects  
     associated with an MdmCube, [2-16](#)  
 container  
     of a BaseMetadataObject, [2-3](#)  
 Context11g.java example program, [1-7](#)  
 count method  
     example of, [5-15](#)  
 CreateAndBuildAW.java example program, [1-7](#)  
 createCursor method  
     example of, [6-24](#), [8-11](#), [9-1](#), [9-3](#)  
 createCursorManager method  
     example of, [6-24](#), [8-11](#), [9-1](#)  
 createListSource method  
     example of, [5-19](#), [6-14](#), [6-21](#), [6-22](#)  
 createParameterizedSource method  
     example of, [5-18](#)  
 createRangeSource method  
     example of, [6-6](#)  
 createRootTransaction method, [7-1](#)  
 createSource method  
     example of, [5-19](#), [6-15](#), [6-23](#)  
 createSQLCursorManager method, [8-7](#)  
 CreateValueHierarchy.java example program, [4-5](#)  
 crosstab view  
     example of, [6-3](#)  
     navigating Cursor for, example, [9-7](#), [9-9](#)  
 CubeDimensionalityMap objects  
     contained by a CubeMap, [2-16](#)  
 CubeDimensionalityMap objects (*continued*)  
     creating, [4-9](#)  
 CubeMap objects  
     creating, [4-9](#)  
     specifying a Query for, [2-16](#)  
 CubeOrganization objects  
     contained by an MdmCube, [2-16](#)  
 cubes  
     as dimensional data objects, [1-3](#)  
     consistent, [2-17](#)  
     creating, [4-8](#)  
     example of, [6-15](#)  
     metadata object representing, [2-16](#)  
 current position in a Cursor, definition, [8-7](#)  
 current Transaction, [7-2](#), [7-6](#)  
 Cursor objects  
     created in the current Transaction, [8-2](#)  
     creating, [8-1](#)  
     creating, example of, [6-15](#), [9-1](#)  
     current position, definition, [8-7](#)  
     CursorManager objects for creating, [8-7](#)  
     extent calculation, example, [9-13](#)  
     extent, definition, [8-12](#)  
     faster and slower varying components, [8-3](#)  
     fetch size, definition, [8-13](#)  
     getting children of, example, [9-3](#)  
     getting the values of, examples, [9-2](#)  
     parent starting and ending position, [8-12](#)  
     position, [8-7](#)  
     retrieving data with, [1-7](#)  
     Source objects for which you cannot create, [8-2](#)  
     span, definition, [8-12](#)  
     specifying fetch size for a table view, example, [9-16](#)  
     specifying the behavior of, [8-5](#), [9-12](#)  
     starting and ending positions of a value, example of calculating, [9-14](#)  
     structure, [8-3](#)  
 cursor package  
     description, [1-2](#)  
 CursorInfoSpecification interface, [8-5](#)  
 CursorManager class, [8-7](#)  
 CursorManager objects  
     closing before rolling back a Transaction, [7-7](#)  
     creating, [8-1](#)  
     creating, example of, [6-15](#), [9-1](#)  
     updating the CursorManagerSpecification, [8-7](#)  
 CursorPrintWriter.java example program, [1-7](#)  
 CursorSpecification class, [8-5](#)  
 CursorSpecification objects  
     getting from a CursorManagerSpecification, example, [9-12](#)

## D

data  
     retrieving, [1-7](#), [8-1](#)

- data (*continued*)
  - specifying, [1-6](#), [5-1](#)
- data objects
  - first-class, [2-9](#)
- data store
  - definition, [1-6](#)
  - exploring, [3-4](#)
  - gaining access to data in, [1-6](#), [2-15](#), [3-3](#)
  - scope of, [3-3](#)
- data types
  - converting, [6-1](#)
  - of Source objects, [5-3](#)
    - See also* SQL data types
- data warehouse, [1-5](#)
- database schemas
  - represented by MdmDatabaseSchema objects, [2-14](#)
- DataProvider objects
  - creating, [3-2](#)
  - needed to create MdmMetadataProvider, [3-4](#)
- deployment package
  - description, [1-3](#)
- derived Source objects
  - definition, [5-2](#)
- descending
  - comparison rules in a join operation, [5-7](#)
- descriptions
  - metadata objects for, [2-6](#)
  - types provided by API, [2-6](#)
- dimension levels
  - mapping, [4-3](#)
  - metadata object for, [2-20](#)
- dimensional data model
  - associations between classes, [2-15](#)
  - description, [1-3](#)
  - designing an OLAP, [1-5](#)
  - implementing, [1-5](#)
  - objects corresponding to MDM objects, [2-2](#)
  - star schema as a, [1-5](#)
- dimensioned Source
  - definition, [5-12](#)
- dimensions
  - as dimensional data objects, [1-4](#)
  - creating, [4-2](#)
  - dimensioning measures, [2-19](#)
  - MdmDimension classes, [2-19](#)
  - MdmDimension objects, [4-2](#)
  - member value formatting, [1-6](#)
  - metadata objects representing, [2-19](#)
- distinct method
  - description, [6-2](#)
  - example of, [6-4](#)
- div method
  - example of, [6-20](#)
- drilling in a hierarchy
  - example of, [6-17](#)
- dynamic queries, [10-1](#)

- dynamic Source objects
  - definition, [5-2](#)
  - example of getting, [10-9](#)
  - produced by a Template, [10-1](#)
- DynamicDefinition class, [10-4](#)

## E

---

- edges of a cube
  - creating, [4-2](#)
  - definition, [1-4](#)
  - pivoting, example of, [6-15](#)
- elements
  - of a Source, [5-3](#)
- empty Source objects
  - definition, [5-2](#)
- EnableMVs.java example program, [2-28](#)
- end date
  - attribute, [2-24](#)
  - of a time dimension, [2-20](#)
- ET views
  - embedded total views for OLAP metadata objects, [2-28](#)
    - See also* OLAP views
- example programs
  - compressed file containing, [1-7](#)
  - sample schema for, [1-7](#)
- executeBuild method
  - example of, [4-11](#)
- exportFullXML methods
  - description, [2-10](#)
  - example of, [4-11](#)
- exportIncrementalXML methods
  - description, [2-10](#)
- exporting XML templates, [2-10](#), [4-11](#)
- Expression objects
  - creating, [4-3](#)
  - example of, [4-9](#)
- extent of a Cursor
  - definition, [8-12](#)
  - example of calculating, [9-13](#)
  - use of, [8-12](#)
- extract method
  - description, [6-14](#)
  - example of, [5-19](#), [6-14](#), [6-21](#), [6-22](#)
- extraction input
  - definition, [5-13](#)

## F

---

- faster varying Cursor components, [8-3](#)
- fetch size of a Cursor
  - definition, [8-13](#)
  - example of specifying, [9-16](#)
  - reasons for specifying, [8-13](#)
- findOrCreateAttributeMap method
  - example of, [4-3](#), [4-4](#)

- findOrCreateAW method
  - example of, [4-2](#)
- findOrCreateAWCubeOrganization method
  - example of, [4-9](#)
- findOrCreateAWPrimaryDimensionOrganization method
  - example of, [4-3](#)
- findOrCreateBaseAttribute method
  - description, [2-25](#)
  - example of, [4-7](#)
- findOrCreateBaseMeasure method
  - example of, [2-34](#), [4-9](#)
- findOrCreateCube method
  - example of, [2-29](#), [4-8](#)
- findOrCreateCubeDimensionalityMap method
  - example of, [4-10](#)
- findOrCreateDerivedMeasure method, [2-16](#)
- findOrCreateDescription method, [2-6](#)
- findOrCreateDimensionLevel method
  - example of, [4-3](#), [4-4](#)
- findOrCreateHierarchyLevel method
  - example of, [4-5](#)
- findOrCreateLevelHierarchy method
  - example of, [2-31](#)
- findOrCreateMeasureMap method
  - example of, [4-9](#)
- findOrCreateMemberListMap method
  - example of, [4-3](#)
- findOrCreateStandardDimension method
  - example of, [4-3](#)
- first-class data objects, [2-9](#)
- fromSyntax method
  - example of, [4-3](#)
- fundamental Source objects
  - definition, [5-2](#)
  - for data types, [5-3](#)
- FundamentalMetadataObject class
  - representing data types, [5-3](#)
- FundamentalMetadataProvider objects
  - example of, [5-4](#)

## G

---

- generated SQL, getting, [8-1](#)
- getAncestorsAttribute method, [2-21](#)
- getAttributeGroupName method, [2-26](#)
- getContainedByObject method, [2-3](#)
- getDataType method
  - of a Source, [5-4](#)
  - of a Source, example of, [6-6](#), [6-8](#), [6-19](#)
- getEmptySource method
  - example of, [5-8](#)
- getETAttributeColumn method, [2-25](#)
- getID method
  - example of, [5-19](#)
  - of a BaseMetadataObject, [2-4](#)
  - of a Source, [5-5](#)

- getInputs method, [5-12](#)
- getLevelAttribute method
  - example of, [6-6](#)
- getMdmMetadataProvider method
  - example of, [3-4](#)
- getMetadataObject method, [2-9](#)
- getMetadataObjects method, [2-9](#)
- getNewName method, [2-4](#)
- getOutputs method, [5-8](#)
- getOwner method, [2-3](#)
- getParentAttribute method, [2-21](#)
- getRootSchema method, [2-9](#)
- getSource method
  - example of, [3-9](#), [6-6](#), [6-17](#)
  - for getting Source produced by a Template, example, [10-9](#)
  - in DynamicDefinition class, [10-1](#)
- getTopLevelObject method
  - example of, [4-9](#)
- getType method, [5-4](#)
- getValidNamespaces method, [2-5](#)
- getVoidSource method, [5-2](#)
- Global schema for example programs, [1-7](#)
- GLOBAL\_AWJ sample analytic workspace, [1-7](#)
- grouping attributes, [2-26](#)
- gt method
  - of a Source, example of, [6-3](#)

## H

---

- hierarchical sorting
  - example of, [6-19](#)
- hierarchies
  - as dimensional data objects, [1-4](#)
  - creating, [4-4](#)
  - lineage in materialized views, [2-16](#)
  - lineage in OLAP views, [2-26](#)
  - ragged, [2-21](#)
  - skip-level, [2-21](#)

## I

---

- ID
  - getting metadata objects by, [2-9](#)
  - of a metadata object, [2-4](#)
  - of a Source, [5-5](#)
    - See also* unique identifiers
- importing XML templates, [2-11](#), [4-11](#)
- importXML methods
  - description, [2-11](#)
- indexes
  - for attributes, [2-26](#)
- inputs
  - of a derived Source, [5-12](#)
  - of a primary Source, [5-12](#)
  - of a Source
    - definition, [5-11](#)

inputs (*continued*)  
    of a Source (*continued*)  
    deriving with the value method, [5-15](#), [5-16](#)  
    matching with a Source, [5-13](#)  
    obtaining, [5-12](#)  
    types of, [5-13](#)  
interval method  
    example of, [6-23](#)  
isSubType method  
    example of, [5-5](#)

## J

---

Java archive (JAR) files, required, [A-1](#)  
Java Development Kit, version required, [A-1](#)  
JDBC  
    creating connections, [3-2](#)  
    libraries required, [A-1](#)  
join method  
    description, [5-6](#), [6-2](#)  
    examples of, [6-2](#)  
    full signature, [5-6](#)  
    rules governing matching an input with a Source,  
        [5-13](#)  
joined parameter  
    of a join method, [5-6](#)  
joinHidden method  
    example of, [5-11](#), [6-20](#), [6-22](#)

## L

---

lag method  
    example of, [6-21](#)  
languages  
    specifying for an attribute, [2-26](#)  
leaves of a hierarchy  
    defined, [2-21](#)  
legacy metadata objects  
    namespaces for, [2-5](#)  
    supporting, [2-4](#)  
level-based hierarchy, [2-21](#)  
levels  
    as dimensional data objects, [1-5](#)  
    creating, [4-4](#)  
    MdmDimensionLevel objects, [2-20](#)  
lineage  
    populating attribute hierarchy values, [2-26](#)  
list Source objects  
    definition, [5-2](#)  
    example of creating, [6-6](#)  
local dimension member values, [1-6](#)

## M

---

mapping  
    dimension levels, [4-3](#)  
    hierarchy levels, [4-4](#)

mapping (*continued*)  
    measures, [4-9](#)  
    objects contained by an MdmCube, [2-16](#)  
mapping package  
    description, [1-3](#)  
matching an input with a Source  
    example of, [5-15](#), [5-16](#)  
    rules governing, [5-13](#)  
materialized views  
    for a cube, [2-16](#)  
    for OLAP metadata, [2-28](#)  
    including hierarchy lineage, [2-16](#)  
    populating attribute hierarchy lineage for, [2-26](#)  
    prefixes for attribute columns in, [2-28](#)  
MDM metadata model  
    description, [2-2](#)  
mdm package  
    description, [1-3](#)  
MdmAttribute objects  
    creating, [4-7](#)  
    description, [2-23](#)  
    example of the values of, [2-23](#)  
    inputs of, [5-12](#)  
MdmBaseAttribute class  
    description, [2-25](#)  
MdmBaseAttribute objects  
    creating, [2-25](#), [4-7](#)  
    mapping, [2-25](#), [4-8](#)  
    mapping, example of, [4-3](#)  
MdmBaseMeasure objects  
    creating, [4-9](#)  
    description, [2-17](#)  
MdmCube class  
    description, [2-16](#)  
MdmCube objects  
    associations, [2-17](#)  
    corresponding to a fact table or view, [2-16](#)  
    example of creating, [4-8](#)  
MdmDatabaseSchema objects  
    creating, [4-2](#)  
    definition, [2-14](#)  
    owner of top-level objects, [2-9](#)  
MdmDerivedAttribute class  
    description, [2-28](#)  
MdmDerivedMeasure objects  
    description, [2-18](#)  
MdmDescription objects  
    associations, [2-6](#)  
MdmDescriptionType objects  
    associations, [2-6](#)  
    creating, [2-6](#)  
MdmDimension classes  
    description, [2-19](#)  
MdmDimension objects  
    creating, [4-2](#)  
    example of getting related objects, [3-7](#), [3-8](#)  
    related MdmAttribute objects, [2-23](#)

- MdmDimensionLevel objects
  - creating, [4-3](#)
  - description, [2-20](#)
- MdmHierarchy class, [2-21](#)
- MdmHierarchy objects
  - creating, [4-4](#)
- MdmHierarchyLevel class
  - description, [2-23](#)
- MdmHierarchyLevel objects
  - creating, [4-4](#)
  - mapping, [4-4](#)
- MdmLevelHierarchy objects
  - creating, [4-4](#)
  - description, [2-21](#)
- MdmMeasure objects
  - creating, [4-9](#)
  - description, [2-17](#)
  - inputs of, [5-12](#)
  - origin of values, [2-18](#)
- MdmMemberListMapOwner interface
  - implemented by MdmPrimaryDimension, [2-20](#)
- MdmMetadataProvider class
  - associations with MdmSchema subclasses, [2-13](#)
- MdmMetadataProvider objects
  - creating, [3-4](#)
  - description, [2-9](#), [3-4](#)
- MdmObject class
  - 10g accessor methods for descriptions, [2-6](#)
  - 11g methods for descriptions, [2-6](#)
  - associations with descriptions, [2-6](#)
- MdmOrganizationalSchema objects
  - description, [2-14](#)
- MdmPrimaryDimension class
  - interfaces implemented by, [2-20](#)
- MdmPrimaryDimension objects
  - creating, [4-3](#)
  - description, [2-19](#)
- MdmQuery interface
  - implemented by MdmPrimaryDimension, [2-20](#)
- MdmRootSchema class, [2-9](#)
- MdmRootSchema objects
  - description, [2-13](#)
- MdmSchema class
  - associations between subclass and MdmMetadataProvider, [2-13](#)
- MdmSchema objects
  - getting contents of, [3-6](#)
  - subclasses of, [2-13](#)
- MdmSingleValuedAttribute class
  - description, [2-24](#)
- MdmSource class, [2-15](#)
- MdmStandardDimension objects
  - creating, [4-3](#)
  - description, [2-19](#)
- MdmSubDimension class, [2-20](#)
- MdmTable objects
  - getting, [2-14](#), [4-9](#)
- MdmTimeDimension objects
  - creating, [4-3](#)
  - description, [2-20](#)
- MdmValueHierarchy class
  - description, [2-22](#)
- MdmValueHierarchy objects
  - example of, [4-5](#)
- MdmViewColumn class, [2-3](#)
- MdmViewColumn objects, [2-25](#)
- MdmViewColumnOwner interface
  - implemented by MdmPrimaryDimension, [2-20](#)
- measure folders
  - represented by MdmOrganizationalSchema objects, [2-14](#)
- MeasureMap objects
  - contained by a CubeMap, [2-16](#)
  - creating, [4-9](#)
- measures
  - as dimensional data objects, [1-4](#)
  - creating, [4-9](#)
  - dimensioned by dimensions, [2-19](#)
  - getting values from, [5-14](#)
  - MdmMeasure objects representing, [2-17](#)
  - sources of data for, [2-17](#)
- MemberListMap objects
  - creating, [4-3](#)
- members
  - of an MdmDimension, [2-19](#)
  - of an MdmDimensionLevel, [2-20](#)
- metadata
  - creating, [4-1](#)
  - creating a provider, [3-4](#)
  - discovering, [3-3](#)
  - mapping, [4-1](#)
- metadata model
  - implementing, [1-5](#)
  - MDM, [2-2](#)
- metadata objects
  - classifying, [2-8](#)
  - creating OLAP, [1-5](#)
  - getting and setting names for, [2-4](#)
  - getting by ID, [2-9](#)
  - in example programs, [1-7](#)
  - OLAP, [1-6](#)
  - renaming, [2-4](#)
  - representing data sources, [2-15](#)
  - restricting access to, [2-14](#)
  - supporting legacy, [2-4](#)
  - top-level, [2-14](#)
  - unique identifiers of, [2-4](#)
- metadata package
  - description, [1-3](#)
  - subpackages, [2-2](#)
- metadata reader modes, [2-5](#)
- MetadataObject interface
  - implemented by MdmPrimaryDimension, [2-20](#)
- MetadataState class

MetadataState class (*continued*)  
example of implementation, [10-8](#)  
movingTotal method  
example of, [6-22](#)  
multidimensional metadata objects  
corresponding to dimensional data model objects,  
[2-2](#)  
corresponding to relational objects, [2-3](#)  
multilingual attributes, [2-26](#)  
multiple user sessions, [1-1](#)

## N

---

names  
getting and setting for metadata objects, [2-4](#)  
namespaces  
description, [2-5](#)  
nested outputs  
getting values from a Cursor with, example, [9-4](#)  
of a Source, definition, [9-2](#)  
null Source objects  
definition, [5-2](#)  
nullSource method, [5-2](#)  
NumberParameter objects  
example of, [6-23](#)

## O

---

ojdbc6.jar file, [A-2](#)  
OLAP Java API  
description, [1-1](#)  
required class libraries, [A-1](#)  
sample schema for examples, [1-7](#)  
software components, [A-1](#)  
uses of, [1-1](#), [1-8](#)  
OLAP metadata, [1-5](#)  
OLAP metadata objects, [1-6](#)  
OLAP views  
description, [2-29](#)  
getting name of cube view, [2-29](#)  
getting name of dimension or hierarchy view,  
[2-30](#)  
populating attribute hierarchy lineage in, [2-26](#)  
olap\_api.jar file, [A-2](#)  
Oracle OLAP  
database administration and management tasks  
related to, [1-1](#)  
Oracle Technology Network (OTN), [1-7](#)  
ORACLE\_HOME environment variable, [A-2](#)  
OracleConnection objects  
creating, [3-2](#)  
OracleDataSource objects  
creating, [3-2](#)  
outputs  
getting from a CompoundCursor, example, [9-3](#)  
getting from a CompoundCursorSpecification,  
example, [9-12](#)

outputs (*continued*)  
getting nested, example, [9-4](#)  
in a CompoundCursor  
positions of, [8-8](#)  
of a Source  
definition, [5-8](#)  
hiding, [5-11](#)  
obtaining, [5-8](#)  
order of, [6-3](#)  
producing, [5-8](#)  
owner  
of a BaseMetadataObject, [2-3](#)

## P

---

package attribute  
MdmAttribute for the PRODUCT\_AWJ  
dimension, [2-23](#)  
packages  
in the OLAP Java API, [1-2](#)  
metadata, [2-2](#)  
Parameter objects  
description, [5-18](#)  
example of, [5-18](#), [6-15](#), [6-23](#)  
parameterized Source objects  
definition, [5-2](#)  
description, [5-18](#)  
example of, [5-18](#), [6-15](#), [6-23](#)  
parent attribute  
method for getting, [2-21](#)  
parent-child relationships  
in a level hierarchy, [2-21](#)  
in hierarchies, [2-21](#)  
pivoting cube edges, example of, [6-15](#)  
position method  
description, [6-2](#)  
example of, [6-6](#)  
positions  
of a CompoundCursor, [8-8](#)  
of a Cursor, [8-7](#)  
of a ValueCursor, [8-7](#)  
parent starting and ending, [8-12](#)  
prefixes  
for attribute column in materialized view, [2-28](#)  
primary Source objects  
definition, [5-2](#)  
result of getSource method, [3-9](#)  
privileges  
specifying, [1-6](#)

## Q

---

queries  
creating using Source methods, [6-1](#)  
definition, [1-5](#)  
dynamic, [10-1](#)  
represented by Source objects, [1-6](#), [5-1](#)

queries (*continued*)  
retrieving data specified by, [1-7](#)  
Source objects that are not, [8-2](#)  
specifying data, [1-6](#)  
SQL, of OLAP views, [2-29](#)  
steps in retrieving results of, [9-1](#)

Query class, [1-5](#)

Query objects

associating with a CubeMap, [2-16](#)

creating, [4-9](#)

query rewrite, [2-16](#)

## R

---

ragged hierarchies, [2-21](#)

range Source objects

definition, [5-2](#)

example of creating, [6-6](#)

read Transaction object, [7-2](#)

recursiveJoin method

description, [6-2](#)

example of, [6-7](#), [6-19](#)

signature of, [5-1](#)

regular input

definition, [5-13](#)

relating Source objects

with inputs, [5-11](#)

relational objects

corresponding to MDM objects, [2-3](#)

relational schemas

for a data warehouse, [1-5](#)

represented by MdmDatabaseSchema objects,  
[2-14](#)

sample, [1-7](#)

relations

reversing with the value method, [6-11](#), [6-17](#)

removeValue method

example of, [6-12](#)

removing

elements in a join operation, [5-7](#)

resource package

description, [1-3](#)

reversing relations

example of, [6-11](#), [6-17](#)

REWRITE\_MV\_OPTION, [2-16](#)

REWRITE\_WITH\_ATTRIBUTES\_MV\_OPTION, [2-16](#)

root schema, [2-9](#), [2-13](#)

root Transaction

definition, [7-1](#)

rotating cube edges, example of, [6-15](#)

## S

---

sample analytic workspace, [1-7](#)

sample schema

used by examples, [1-7](#)

schemas

schemas (*continued*)

getting MdmDatabaseSchema for, [4-2](#)

metadata objects representing, [2-12](#)

represented by MdmDatabaseSchema objects,  
[2-14](#)

sample, [1-7](#)

star, [1-5](#)

selecting

by position, [6-23](#)

by time series, [6-21](#)

by value, [6-4](#), [6-10](#), [6-14](#), [6-15](#), [6-20](#)

elements to include in a join operation, [5-7](#)

selectValue method

example of, [6-4](#), [6-14](#), [6-20](#)

selectValues method

example of, [5-18](#), [6-10](#), [6-15](#)

session package

description, [1-3](#)

sessions

creating a UserSession object, [3-2](#)

sharing connection, [1-1](#)

setAllowAutoDataTypeChange method

example of, [4-7](#), [4-9](#)

setConsistentSolveSpecification method

example of, [4-9](#)

setCreateAttributeIndex method, [2-26](#)

setETAttrPrefix method, [2-28](#)

setExpression method

example of, [4-3](#)

setJoinCondition method, [2-16](#)

setKeyExpression method

example of, [4-3](#)

setLanguage method, [2-26](#)

setMultiLingual method, [2-26](#)

setName method, [2-4](#)

setPopulateLineage method, [2-26](#)

setQuery method

example of, [4-3](#)

setShortValueDescriptionAttribute method, [2-24](#)

setTimeSpanAttribute method, [2-24](#)

setValue method

of a Parameter, example of, [5-19](#), [6-15](#), [6-23](#)

of an MdmDescription, [2-6](#)

setValueDescriptionAttribute method

example of, [4-7](#)

sharing connection, [1-1](#)

SID (system identifier), [3-2](#)

SingleSelectionTemplate class, [7-4](#), [7-7](#), [10-10](#), [B-1](#)

skip-level hierarchies, [2-21](#)

slower varying Cursor components, [8-3](#), [8-10](#)

sort order

determined by comparisonRule parameter, [5-7](#)

sortAscending method

example of, [6-20](#)

sorting hierarchically

example of, [6-19](#)

Source class



- Source class (*continued*)
  - basic methods, [6-1](#)
  - subclasses of, [5-3](#)
- Source objects
  - active in a Transaction object, [8-2](#)
  - base of a join operation, [5-6](#)
  - data type
    - definition, [5-3](#)
    - getting, [5-4](#)
  - dimensioned, [5-12](#)
  - elements of, [5-3](#)
  - getting ID of, [5-5](#)
  - inputs of
    - a derived, [5-12](#)
    - a primary, [5-12](#)
    - definition, [5-11](#)
    - matching with a Source, [5-13](#)
    - obtaining, [5-12](#)
    - types, [5-13](#)
  - kinds of, [5-2](#)
  - methods of getting, [5-2](#)
  - modifiable, [10-1](#)
  - outputs of
    - definition, [5-8](#)
    - obtaining, [5-8](#)
  - parameterized, [5-18](#)
  - representing queries, [1-6](#), [5-1](#)
  - SourceDefinition for, [5-5](#)
  - subtype
    - definition, [5-5](#)
    - obtaining, [5-5](#)
  - type
    - definition, [5-4](#)
    - obtaining, [5-4](#)
- source package
  - description, [1-2](#)
- SourceDefinition class, [5-5](#), [10-1](#)
- SourceGenerator class
  - example of implementation, [10-8](#)
- span of a value in a Cursor
  - definition, [8-12](#), [9-13](#)
- SpecifyAWValues.java
  - example program, [1-7](#)
- SQL
  - getting generated, [1-10](#), [8-1](#)
  - queries of OLAP objects, [2-9](#), [2-14](#)
  - queries of OLAP views, [2-29](#)
- SQL data types
  - allowing automatic changing of, [2-18](#), [2-25](#)
  - specifying for an MdmBaseAttribute, [2-25](#)
  - specifying for an MdmBaseMeasure, [2-18](#)
- SQLCursorManager class, [1-10](#), [8-7](#)
- star schema, [1-5](#)
- StringParameter objects
  - example of, [5-18](#), [6-15](#)
- subtype of a Source object
  - definition, [5-5](#)

- subtype of a Source object (*continued*)
  - matching an input, [5-16](#)
  - obtaining, [5-5](#)
- syntax package
  - description, [1-3](#)

## T

---

- table view
  - navigating Cursor for, example, [9-6](#)
- target dimension
  - of an attribute, [2-25](#)
- Template class
  - designing, [10-4](#)
  - example of implementation, [10-5](#)
- Template objects
  - classes used to create, [10-2](#)
  - for creating modifiable Source objects, [10-1](#)
  - relationship of classes producing a dynamic Source, [10-2](#)
  - Transaction objects used in, [7-3](#)
- templates
  - bind variables in XML, [2-12](#)
  - exporting XML, [2-10](#), [4-11](#)
  - importing XML, [2-11](#), [4-11](#)
- time series
  - selecting based on, [6-21](#)
- time span
  - attribute, [2-24](#)
  - of a time dimension, [2-20](#)
- times method
  - example of, [6-20](#)
- top-level metadata objects
  - creating, [2-14](#)
  - defined, [2-9](#)
  - getting, [2-14](#)
  - listed, [2-14](#)
- TopBottomTemplate class, [7-4](#), [7-7](#), [10-5](#)
- Transaction objects
  - child read and write, [7-2](#)
  - committing, [4-10](#), [7-3](#)
  - creating a Cursor in the current, [8-2](#)
  - current, [7-2](#)
  - example of using child, [7-7](#)
  - getting the current, [7-6](#)
  - preparing, [7-3](#)
  - read, [7-2](#)
  - rolling back, [7-4](#)
  - root, [7-1](#)
  - setting the current, [7-6](#)
  - using in Template classes, [7-3](#)
  - write, [7-2](#)
- transaction package
  - description, [1-3](#)
- TransactionProvider
  - provided by DataProvider, [7-7](#)
- tuple

tuple (*continued*)  
  definition, [2-18](#)  
  in a Cursor, example, [9-5](#)  
  specifying a measure value, [8-8](#)  
type of an Source object  
  definition, [5-4](#)  
  obtaining, [5-4](#)

## U

---

unique dimension member values, [1-6](#)  
unique identifiers  
  of a Source, [5-5](#)  
  of dimension members, [1-6](#)  
  of metadata objects, [2-4](#)  
unique key attributes, [2-28](#)  
UserSession objects  
  creating, [3-2](#)  
  sharing connection, [1-1](#)

## V

---

Value data type, [5-2](#)  
value method  
  description, [6-2](#)  
  example of, [5-15](#), [5-16](#), [6-6](#), [6-10](#), [6-11](#), [6-17](#)  
value separation string, [1-6](#)  
value-based hierarchy, [2-22](#)  
ValueCursor objects  
  getting from a parent CompoundCursor, example,  
    [9-3](#)

ValueCursor objects (*continued*)  
  getting values from, example, [9-2](#), [9-3](#)  
  position, [8-7](#)  
values  
  of a Cursor, [8-3](#), [8-7](#)  
  of the elements of a Source, [5-3](#)  
views  
  materialized, [2-28](#)  
  OLAP, [2-29](#)  
virtual Cursor  
  definition, [8-13](#)  
visible parameter  
  of a join method, [5-7](#)  
void Source objects  
  definition, [5-2](#)

## W

---

write Transaction object, [7-2](#)

## X

---

XML templates  
  bind variables in, [2-12](#)  
  controlling attribute export, [2-11](#)  
  exporting, [2-10](#), [4-11](#)  
  importing, [2-11](#), [4-11](#)  
XMLParserCallback interface, [2-10](#)  
xmlparserv2.jar file, [A-2](#)  
XMLWriterCallback interface, [2-11](#)